

ISL88732

SMBus Level 2 Battery Charger with Boost Mode

FN7946

Rev.0.00

September 25, 2012

The ISL88732 is a highly integrated Lithium-ion battery charger controller, programmable over the SMBus system management bus (SMBus). The ISL88732 is intended to be used in a smart battery charger (SBC) within a smart battery system (SBS) that throttles the charge power such that the current from the AC-adaptor is automatically limited. High efficiency is achieved with a DC/DC synchronous-rectifier buck converter, equipped with diode emulation for enhanced light load efficiency. The ISL88732 charges one to four Lithium-ion series cells, and delivers up to 8A charge current. Integrated MOSFET drivers and bootstrap diode result in fewer components and smaller implementation area. Low offset current-sense amplifiers provide high accuracy with 10mΩ sense resistors. The ISL88732 provides 0.5% end-of-charge battery voltage accuracy.

The ISL88732 is available in a small 5mmx5mm 28 Ld Thin (0.8mm) QFN package.

**Boost Mode**

If system load current is higher than the adapter current limit, ISL88732 will operate in boost mode to draw power from the battery and boost it to adapter voltage. System load current will be supplied partly from the adapter and partly from the battery.

ISL88732 performs this function by (1) detecting high adapter current, (2) reducing charge current to zero and (3) controlling LFET ON time to boost current from the battery and limit current from the adapter.

**Applications**

- Notebook computers
- Tablet PCs

**Features**

- Boost Mode to support Intel “Turbo Mode”
- Pin compatible with ISL88731
- Over-temp and overcurrent protection
- 0.5% battery voltage accuracy
- 4% adapter current limit accuracy
- 3% charge current accuracy
- SMBus 2-wire serial interface
- Charge current limited by SMBus DAC OR analog voltage at the CCLIM pin
- Turbo-boost discharge current limit can be set to 3.3x, 4.85x, 6.37x or 9.31x the charge current limit by SMBus command
- Monitor outputs
  - Adapter current (3% accuracy)
  - Adapter overcurrent ALERT#. Threshold set by resistor divider
  - AC-adaptor detection
- 11-bit battery voltage setting
- 6-bit charge current/adapter current setting
- 8A maximum battery charger current
- 11A maximum adapter current
- +8V to +22V adapter voltage range
- Pb-free (RoHS compliant)

**Typical Operating Performance**

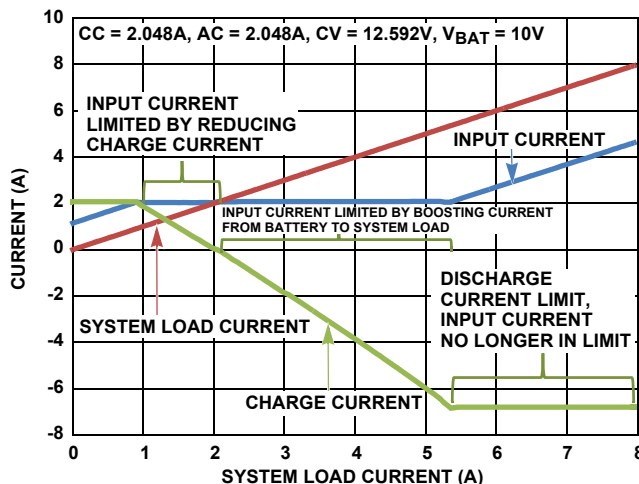

FIGURE 1. ISL88732 CURRENT CONTROL IN 4 MODES

**© Copyright Intersil Americas LLC 2012. All Rights Reserved.**  
**All trademarks and registered trademarks are the property of their respective owners.**

For additional products, see [www.intersil.com/en/products.html](http://www.intersil.com/en/products.html)

---

Intersil products are manufactured, assembled and tested utilizing ISO9001 quality systems as noted in the quality certifications found at [www.intersil.com/en/support/qualandreliability.html](http://www.intersil.com/en/support/qualandreliability.html)

---

*Intersil products are sold by description only. Intersil may modify the circuit design and/or specifications of products at any time without notice, provided that such modification does not, in Intersil's sole judgment, affect the form, fit or function of the product. Accordingly, the reader is cautioned to verify that datasheets are current before placing orders. Information furnished by Intersil is believed to be accurate and reliable. However, no responsibility is assumed by Intersil or its subsidiaries for its use; nor for any infringements of patents or other rights of third parties which may result from its use. No license is granted by implication or otherwise under any patent or patent rights of Intersil or its subsidiaries.*

---

For information regarding Intersil Corporation and its products, see [www.intersil.com](http://www.intersil.com)