

THIS DRAWING IS UNPUBLISHED. RELEASED FOR PUBLICATION 20
 © COPYRIGHT 20 BY - ALL RIGHTS RESERVED.

REVISIONS				
P	LTR	DESCRIPTION	DATE	APVD
A		INITIAL RELEASE	01JUN2015	DW CW
A1		ECR-17-002906	01MAR2017	DW CW
B		ECR-20-014876	04NOV2020	WOR CW

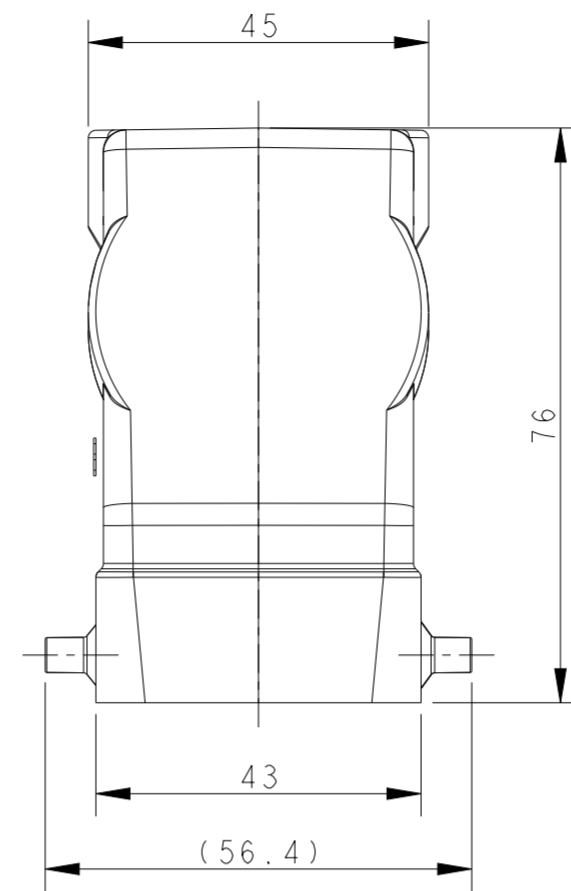
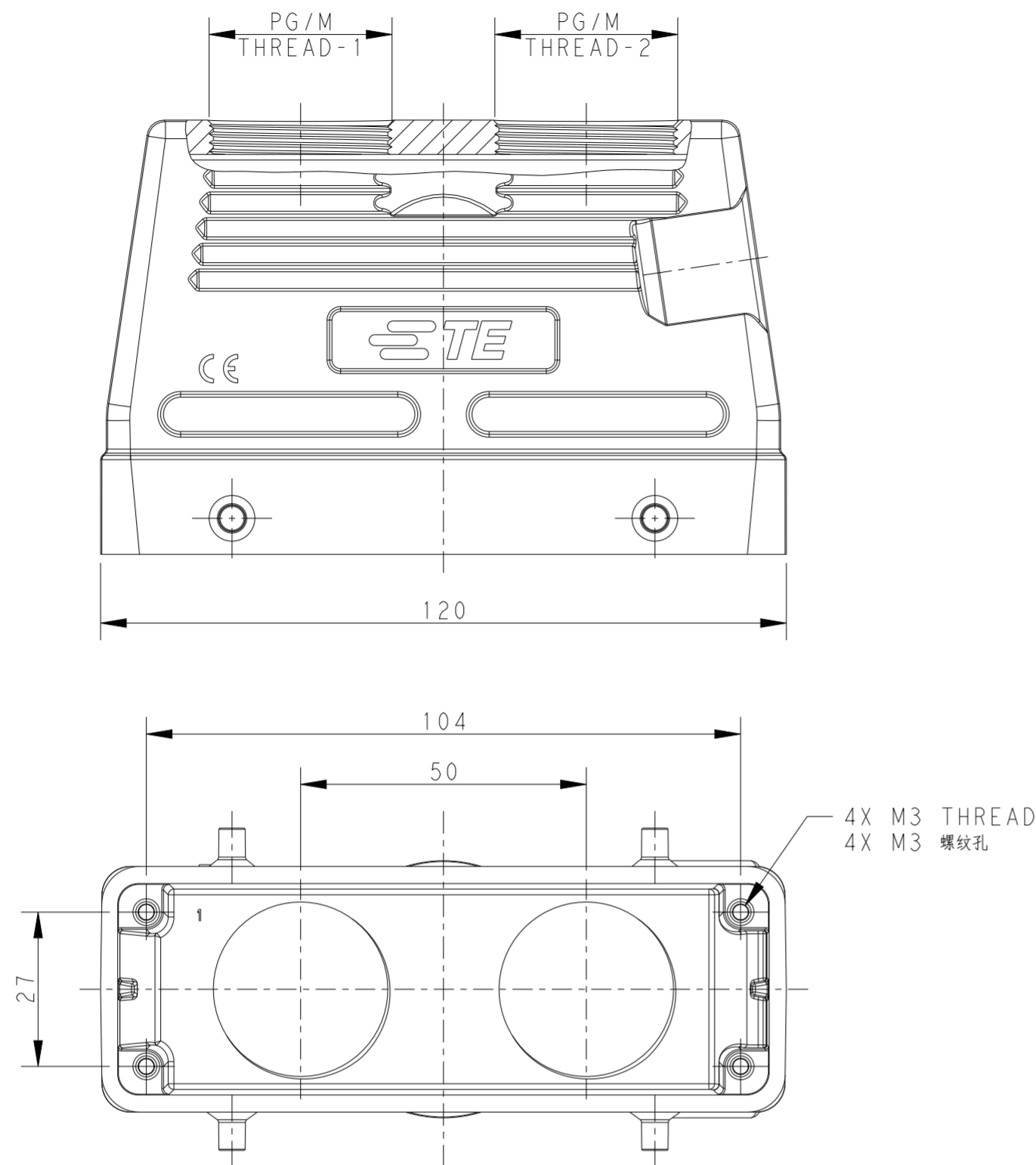

NOTES:
 1. TECHNICAL CHARACTERISTICS:
 HOOD MATERIAL: DIE CAST ALUMINIUM ALLOY
 HOOD SURFACE: POWDER COATED, GREY
 DEGREE OF PROTECTION: IP65 (MATED)

注释:
 1. 技术参数:
 上壳材料: 铝合金
 上壳表面处理: 灰色粉末涂层
 防护等级: IP65(配合)

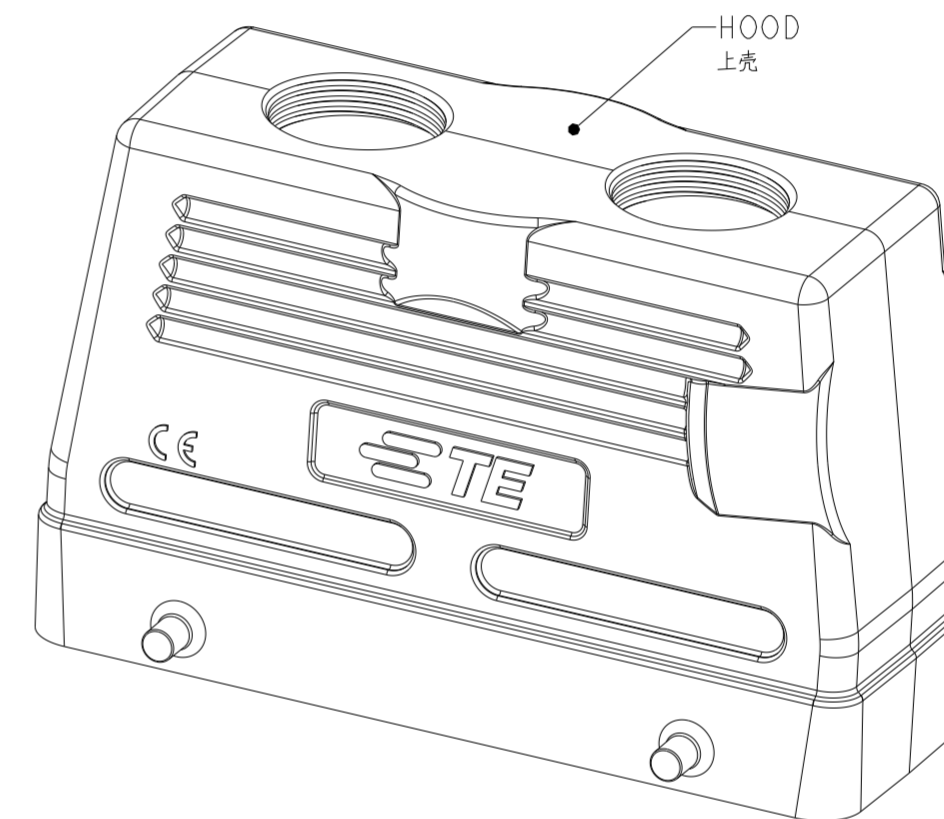

OBSOLETED

T1240243220-000	H24B-TGH-M32/M20	H24B HOOD, TOP ENTRY M32/M20, 4 EAR, HIGH CONSTRUCTION, POWDER COATED, GREY H24B上壳, 顶出M32/M20, 4耳, 高结构, 灰色粉末喷涂	M32	M20
T1240242540-000	H24B-TGH-M25/M40	H24B HOOD, TOP ENTRY M25/M40, 4 EAR, HIGH CONSTRUCTION, POWDER COATED, GREY H24B上壳, 顶出M25/M40, 4耳, 高结构, 灰色粉末喷涂	M25	M40
T1240242532-000	H24B-TGH-M25/M32	H24B HOOD, TOP ENTRY M25/M32, 4 EAR, HIGH CONSTRUCTION, POWDER COATED, GREY H24B上壳, 顶出M25/M32, 4耳, 高结构, 灰色粉末喷涂	M25	M32
T1240241621-000	H24B-TGH-PG16/PG21	H24B HOOD, TOP ENTRY PG16/PG21, 4 EAR, HIGH CONSTRUCTION, POWDER COATED, GREY H24B上壳, 顶出PG16/PG21, 4耳, 高结构, 灰色粉末喷涂	PG16	PG21
T1240240232-000	H24B-TGH-2M32	H24B HOOD, TOP ENTRY 2M32, 4 EAR, HIGH CONSTRUCTION, POWDER COATED, GREY H24B上壳, 顶出2M32, 4耳, 高结构, 灰色粉末喷涂	M32	M32
T1240240225-000	H24B-TGH-2M25	H24B HOOD, TOP ENTRY 2M25, 4 EAR, HIGH CONSTRUCTION, POWDER COATED, GREY H24B上壳, 顶出2M25, 4耳, 高结构, 灰色粉末喷涂	M25	M25
T1240240229-000	H24B-TGH-2PG29	H24B HOOD, TOP ENTRY 2PG29, 4 EAR, HIGH CONSTRUCTION, POWDER COATED, GREY H24B上壳, 顶出2PG29, 4耳, 高结构, 灰色粉末喷涂	PG29	PG29
T1240240221-000	H24B-TGH-2PG21	H24B HOOD, TOP ENTRY 2PG21, 4 EAR, HIGH CONSTRUCTION, POWDER COATED, GREY H24B上壳, 顶出2PG21, 4耳, 高结构, 灰色粉末喷涂	PG21	PG21
T1240240216-000	H24B-TGH-2PG16	H24B HOOD, TOP ENTRY 2PG16, 4 EAR, HIGH CONSTRUCTION, POWDER COATED, GREY H24B上壳, 顶出2PG16, 4耳, 高结构, 灰色粉末喷涂	PG16	PG16
PART NUMBER 零件料号	PART DESCRIPTION 零件描述		PG/M THREAD-1 PG/M 螺纹孔-1	PG/M THREAD-2 PG/M 螺纹孔-2

THIS DRAWING IS A CONTROLLED DOCUMENT.

DWN DAVID WANG 01JUN2015
 CHK CHRIS WANG 01JUN2015
 APVD XIANG XU 01JUN2015

STE TE Connectivity

NAME H24B-TGH-2 M/PG

PRODUCT SPEC 108-137013
 APPLICATION SPEC 114-137013

SIZE A2 CAGE CODE 00779 DRAWING NO. C-T124024XXXXX00 RESTRICTED TO

WEIGHT -

CUSTOMER DRAWING SCALE 1:1 SHEET 1 OF 1 REV B