

BASE CAGE DETAILS

1000163252

SHOWN

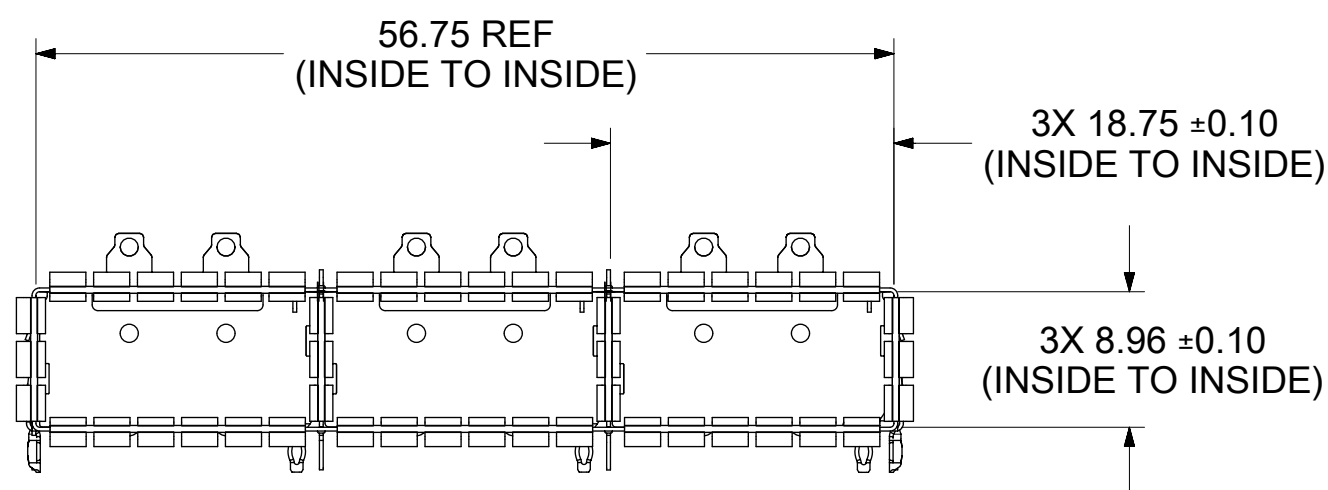
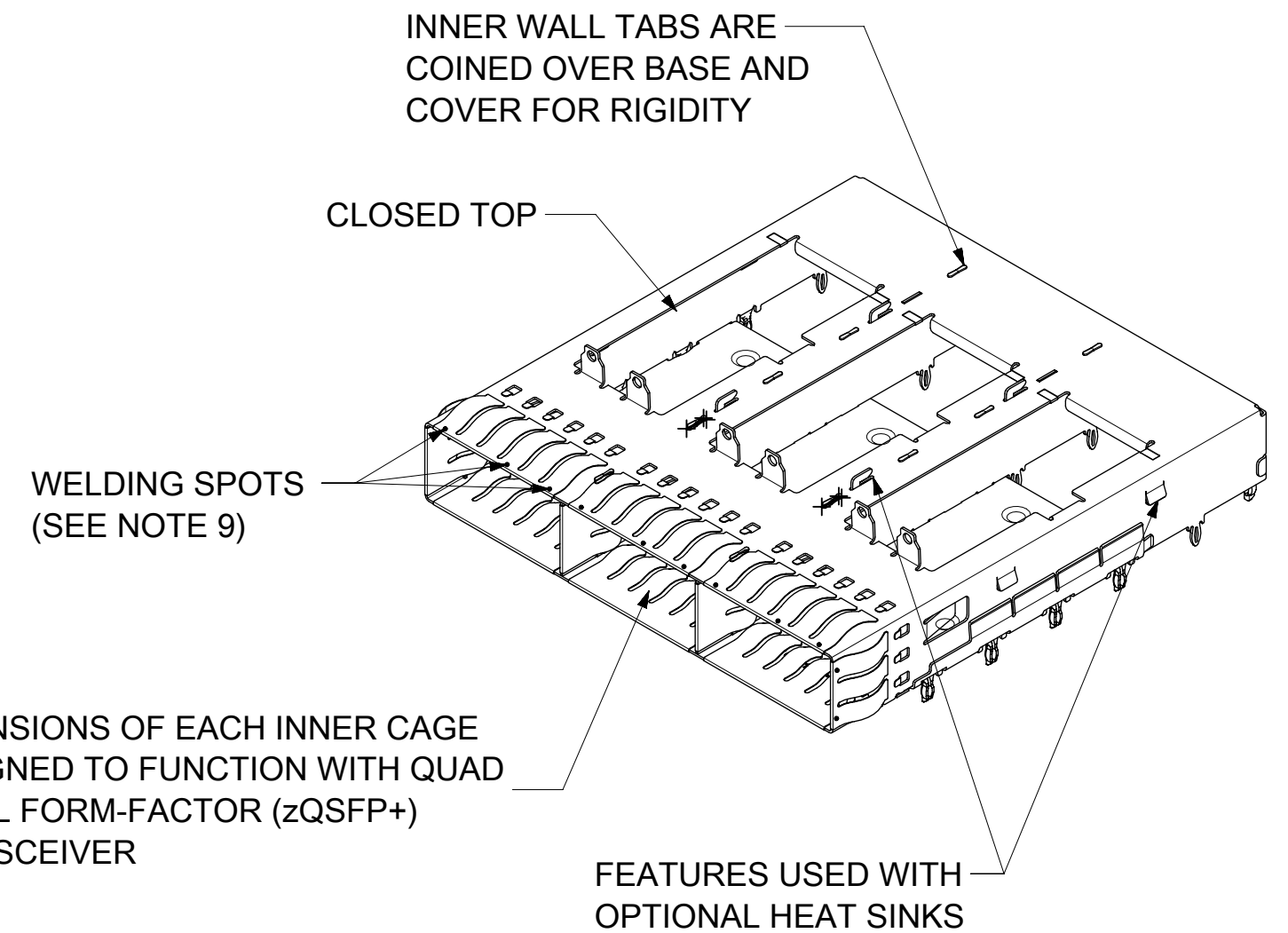
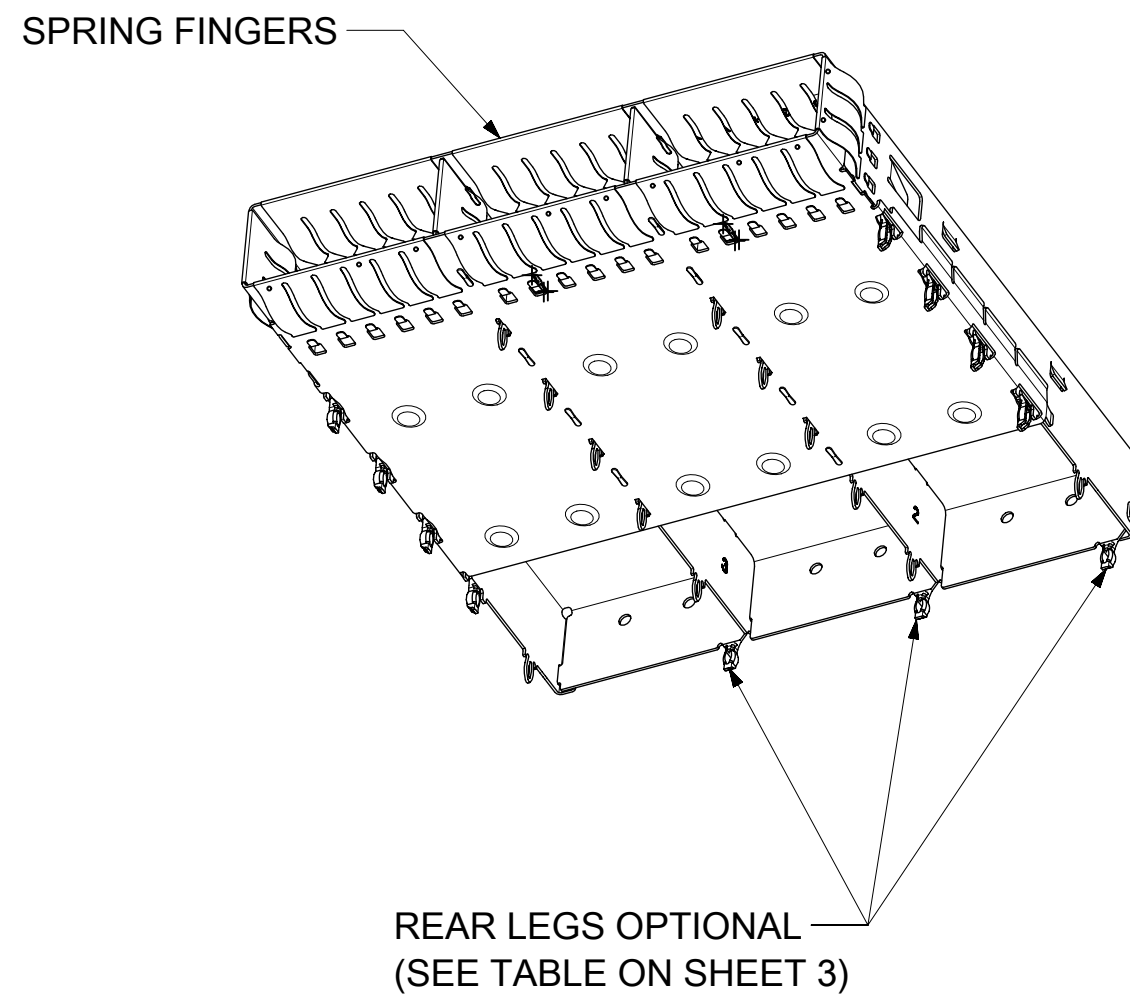
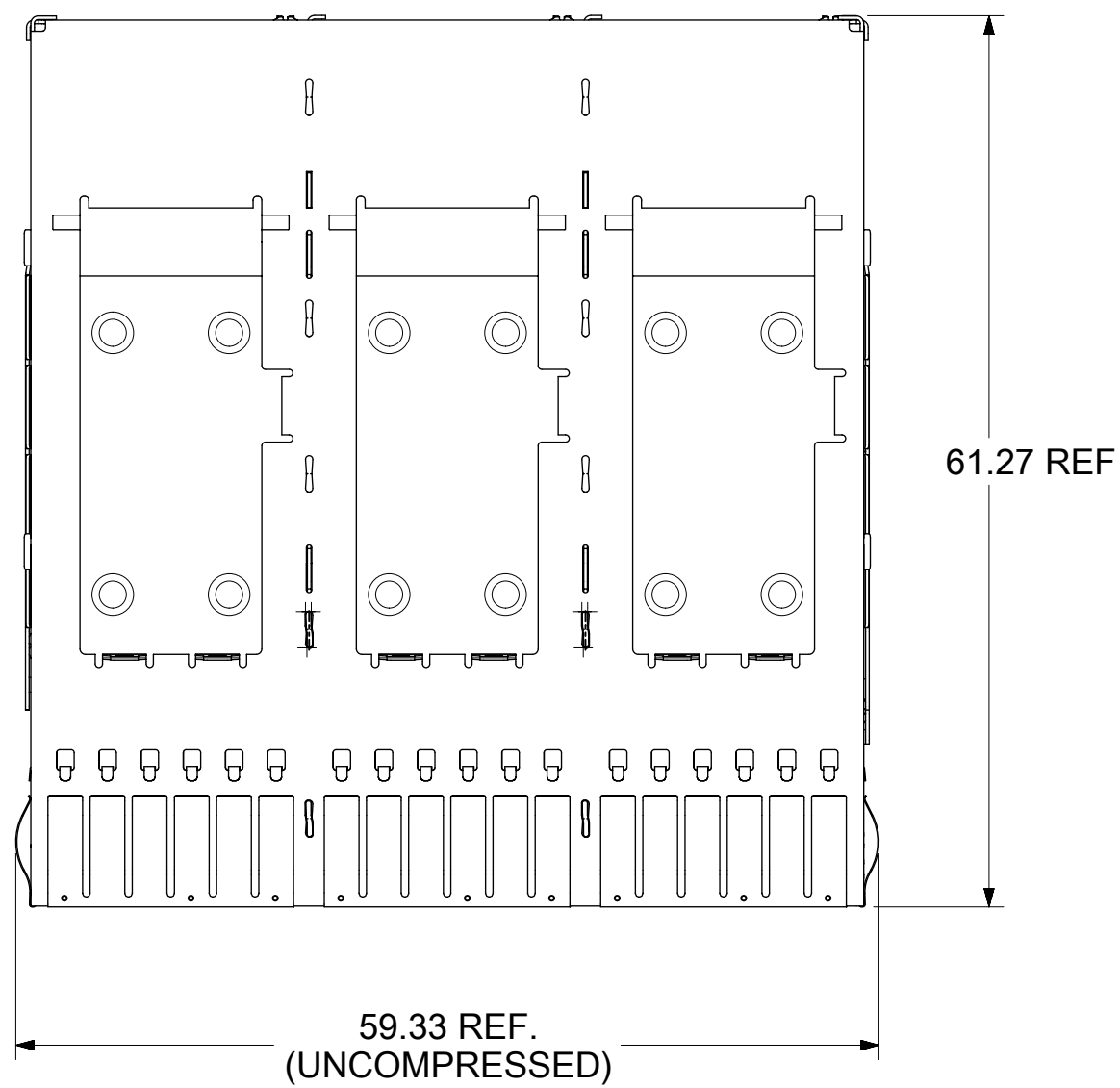

P/N AND WEEK/YEAR DATE CODE TO BE PRINTED ON
BACK OF COMPLETED CAGE ASSEMBLY APPROXIMATELY AS SHOWN.
SEE TABLE BELOW FOR DATE CODE INFORMATION

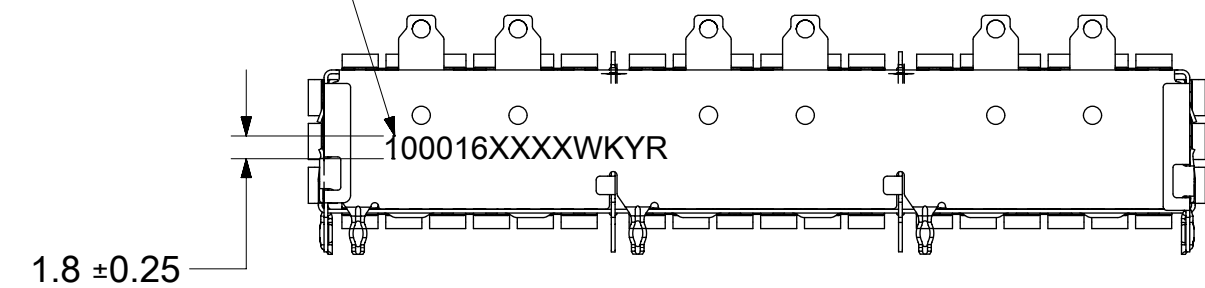
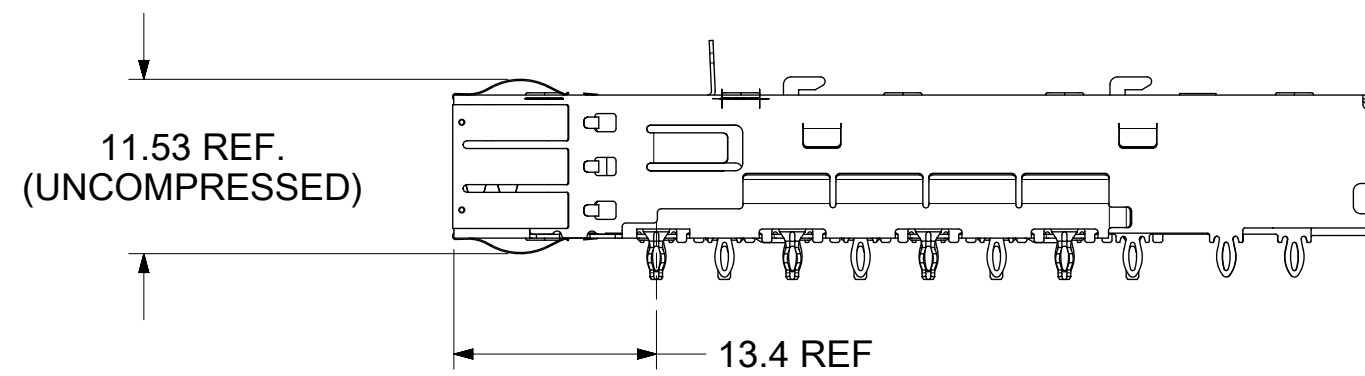

- NOTES:
- MATERIAL: CAGE: STAINLESS STEEL
CENTER WALLS: STAINLESS STEEL
SPRING FINGERS: STAINLESS STEEL
HEAT SINKS: NICKEL PLATED ALUMINUM
HEAT SINK CLIP: STAINLESS STEEL
LIGHT PIPES: POLYCARBONATE (UL 94-V-0)
 - DIMENSIONS MARKED ∇ ARE CRITICAL TO FUNCTION OF THE PART AND MUST BE INSPECTED
 - DRAWING APPLIES TO ALL P/N'S SHOWN ON PAGE 3
 - DURING FINAL INSPECTION, CAGE LEG LOCATIONS AND STRAIGHTNESS MUST BE CHECKED USING APPROPRIATE GO - NO GO GAGE
 - DURING FINAL INSPECTION, CAGE MUST BE INSPECTED TO MAKE SURE LEG CONFIGURATIONS AND PART NUMBERS ARE CORRECT, USE SHEETS 3, 4 AND 5
 - PARTS TO BE INSPECTED PER MOLEX COSMETIC SPEC WI-HP-7-2774 (CLASS B UNLESS OTHERWISE SPECIFIED)
 - PRESS-FIT LEGS 2.44 LONG -
1.57 MINIMUM PCB THICKNESS FOR SINGLE SIDED USE.
2.70 MINIMUM PCB THICKNESS FOR BELLY TO BELLY USE.
 - NO RoHS EXEMPTIONS
 - WELD SPOTS MAY SHOW MATERIAL DISCOLORATION

| WEEK/YEAR DATE CODE TABLE | |
|---------------------------|---|
| WK | WEEK OF THE YEAR 01 THRU 52 (EXAMPLE: 01= FIRST WEEK OF YEAR 52= LAST WEEK OF YEAR) |
| YR | 22, 23, 24 ETC.. (EXAMPLE: YEAR 2022= 22) |

| | | | | | | | | | |
|---|---|------------------------|---------------------------------------|-------------------|---------------------------------|----------------|--------------------------|--------------|--|
| FUNCTIONAL SYMBOLS ∇ = 0 ∇ = 0 ∇ = 0 DIVISIONAL SYMBOLS 4 PLACES ± 3 PLACES ± 2 PLACES ± 0.13 1 PLACE ± 0.25 0 PLACES ± | THIS DRAWING CONTAINS INFORMATION THAT IS PROPRIETARY TO MOLEX ELECTRONIC TECHNOLOGIES, LLC AND SHOULD NOT BE USED WITHOUT WRITTEN PERMISSION | | SCALE 2:1 | | CURRENT REV DESC: SEE REV TABLE | | | | |
| | DIMENSION UNITS mm | | GENERAL TOLERANCES (UNLESS SPECIFIED) | | EC NO: 698867 | | | | |
| | ANGULAR TOL ± 2.0° | | 4 PLACES ± | | DRWN: VISHNM2 | | PRODUCT CUSTOMER DRAWING | | |
| | 3 PLACES ± | | 2 PLACES ± 0.13 | | CHK'D: TKUMARKC | | DOCUMENT NUMBER | | |
| 1 PLACE ± 0.25 | | 1 PLACE ± | | APPR: JCHIANG | | 2022/02/22 | | DOC TYPE | |
| 0 PLACES ± | | 0 PLACES ± | | INITIAL REVISION: | | 2022/03/17 | | DOC PART | |
| DRAFT WHERE APPLICABLE MUST REMAIN WITHIN DIMENSIONS | | THIRD ANGLE PROJECTION | | DRWN: VISHNM2 | | 2022/02/22 | | REVISION | |
| C-SIZE | | DRAWING | | APPR: JCHIANG | | 2022/03/17 | | SERIES | |
| 100016 | | SERIES | | MATERIAL NUMBER | | 1000163200 | | CUSTOMER | |
| SEE P/N TABLE | | GENERAL MARKET | | CUSTOMER | | GENERAL MARKET | | SHEET NUMBER | |
| 1 OF 7 | | | | | | | | | |

CAGE ASSEMBLY OPTIONS

1000163547

SHOWN

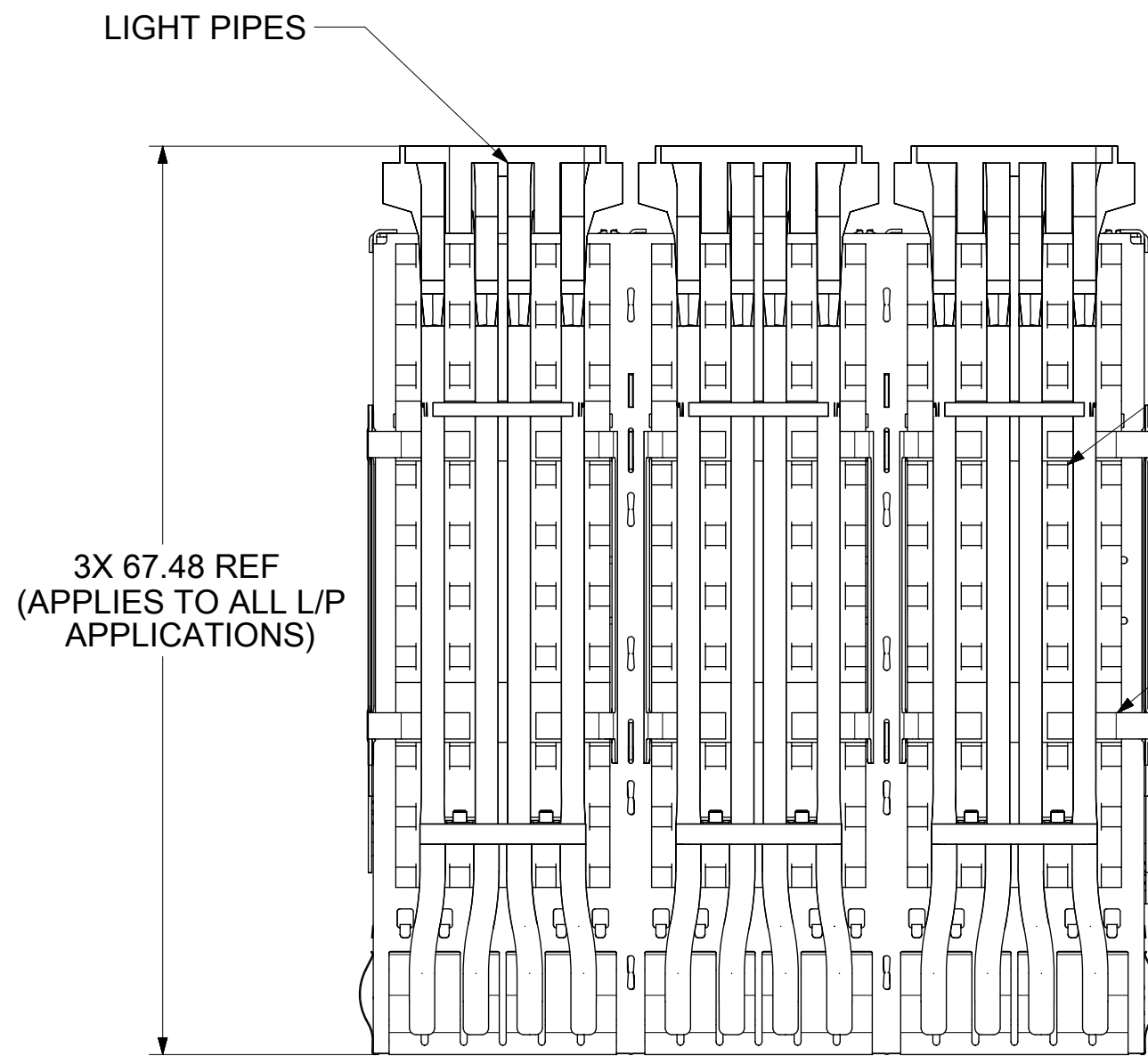

HEAT SINKS

HEAT SINK/CLIP ASSY

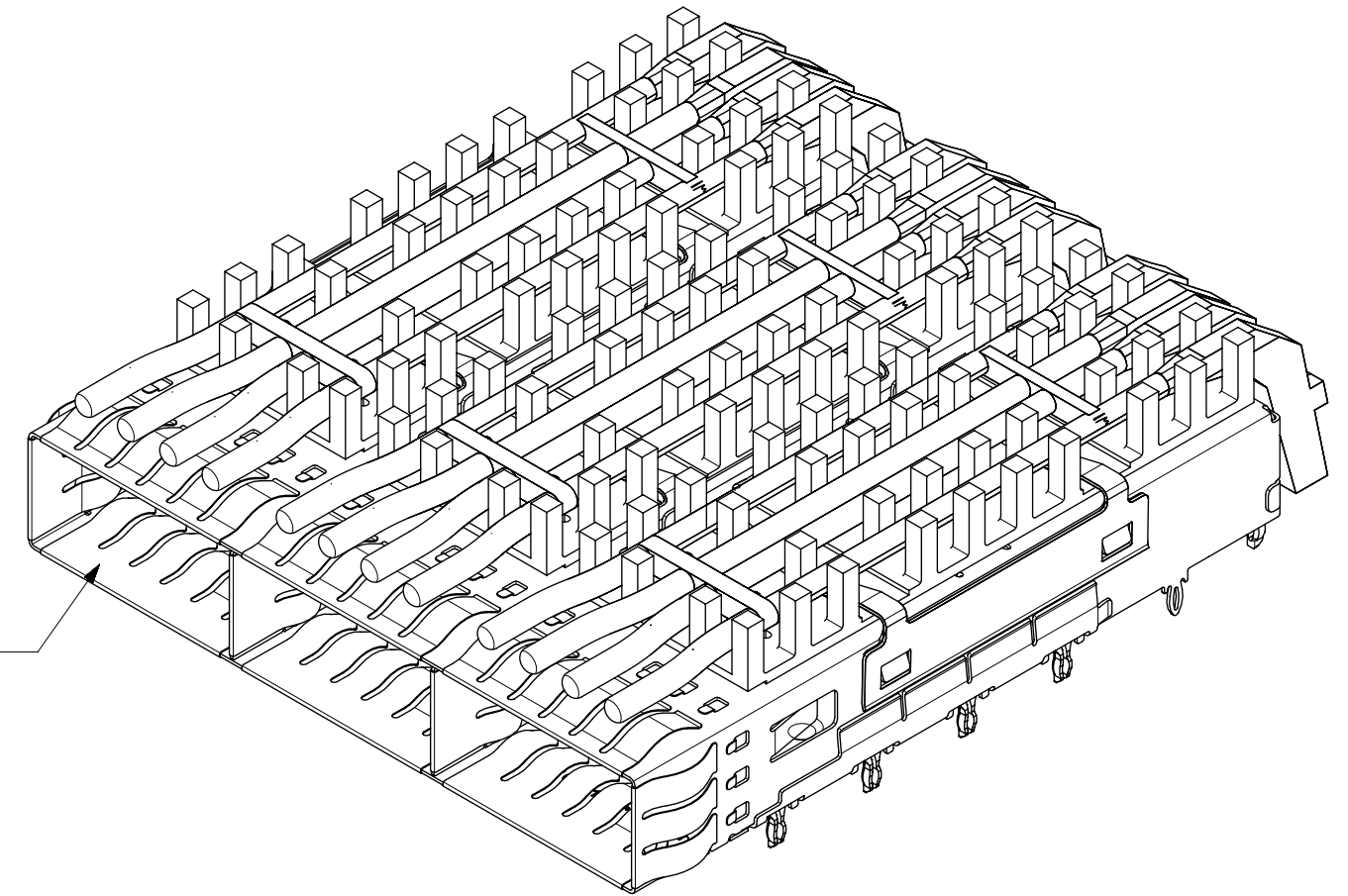

SPRING FINGER

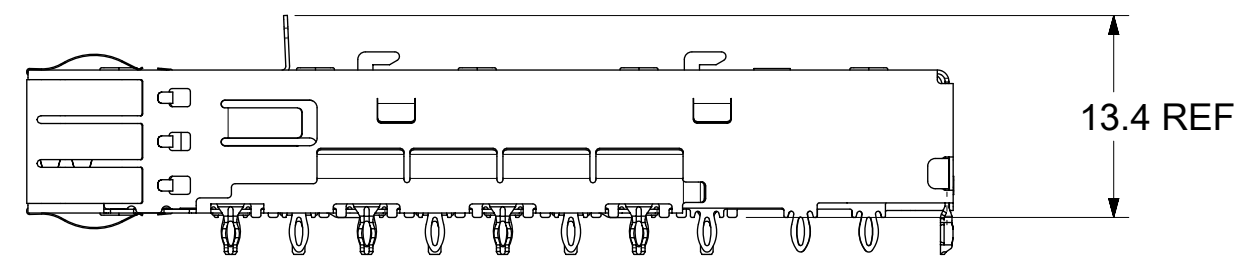

REAR LEG OPTIONS

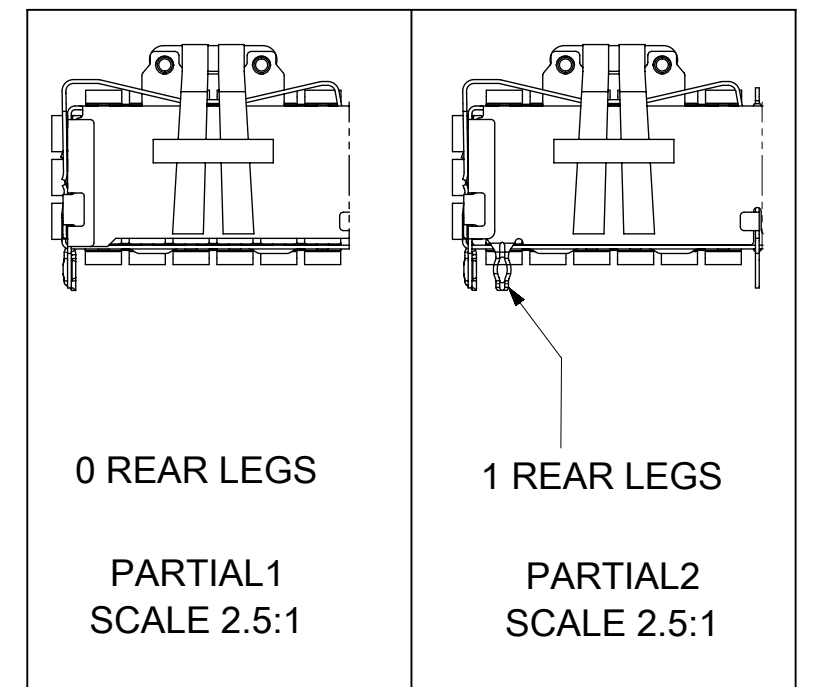
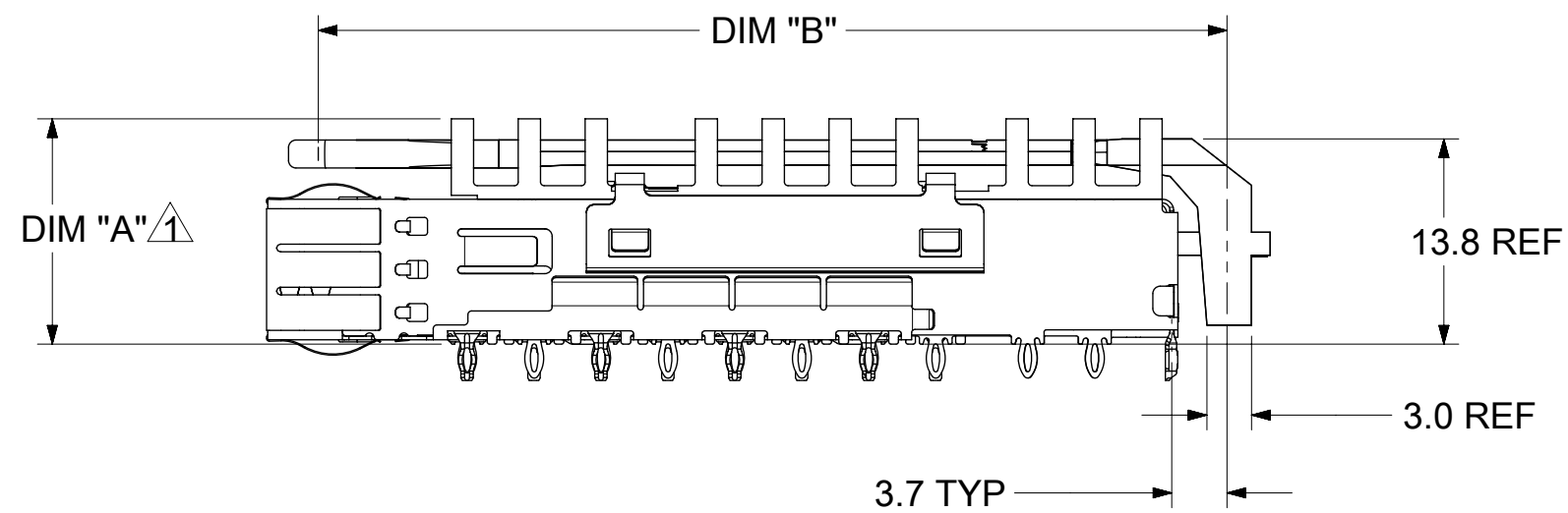
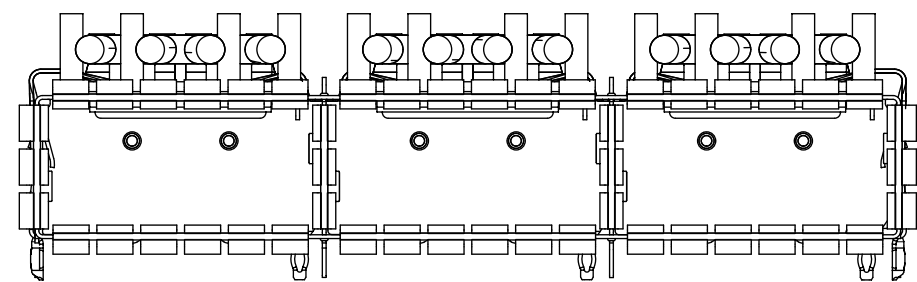

HEATSINK AND LIGHT PIPE COMBINATIONS

HEATSINK USED WITHOUT LIGHTPIPE

QUAD LIGHT PIPE

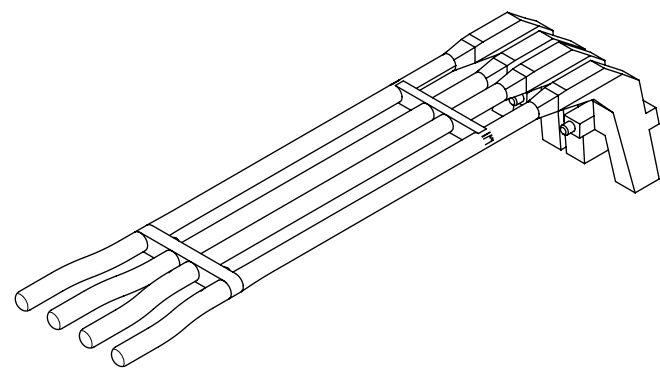

HEATSINK

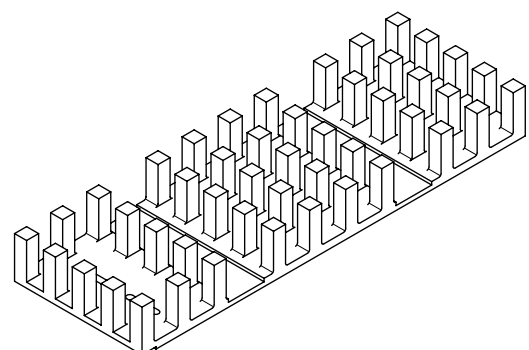

HEATSINK HEIGHT OPTIONS

| OVERALL HEAT SINK HEIGHT | DIM "A" |
|--------------------------|----------|
| PCI | 13.7 REF |
| SAN | 16.0 REF |
| NET | 23.0 REF |

HEIGHT OF HEAT SINK WITH MODULE INSERTED. DIMENSION MAY BE LESS DUE TO MODULE AND HEAT SINK VARIATIONS

| | | | | |
|--|---|------------------------|---------------------------------|------------|
| FUNCTIONAL SYMBOLS | THIS DRAWING CONTAINS INFORMATION THAT IS PROPRIETARY TO MOLEX ELECTRONIC TECHNOLOGIES, LLC AND SHOULD NOT BE USED WITHOUT WRITTEN PERMISSION | | CURRENT REV DESC: SEE REV TABLE | |
| | DIMENSION UNITS | SCALE | | |
| $\nabla_A = 0$ | mm | 2:1 | | |
| $\nabla_E = 0$ | GENERAL TOLERANCES (UNLESS SPECIFIED) | | | |
| | ANGULAR TOL $\pm 2.0^\circ$ | | | |
| DIVISIONAL SYMBOLS | 4 PLACES | \pm | EC NO: 698867 | |
| | 3 PLACES | \pm | DRWN: VISHNM2 | 2022/02/22 |
| | 2 PLACES | ± 0.13 | CHK'D: TKUMARKC | 2022/03/16 |
| | 1 PLACE | ± 0.25 | APPR: JCHIANG | 2022/03/17 |
| 0 PLACES | \pm | INITIAL REVISION: | | |
| DRAFT WHERE APPLICABLE MUST REMAIN WITHIN DIMENSIONS | | THIRD ANGLE PROJECTION | DRAWING | SERIES |
| | | | C-SIZE | 100016 |
| DOCUMENT STATUS | | DOC TYPE | DOC PART | REVISION |
| P1 | RELEASE DATE | 1000163200 | PSD | ASY |
| 2022/03/17 | 10:10:57 | 1000163200 | GENERAL MARKET | A |
| MATERIAL NUMBER | | CUSTOMER | SHEET NUMBER | |
| SEE P/N TABLE | | GENERAL MARKET | 2 OF 7 | |

PART NUMBER SELECTION

NO HEATSINKS
NO LIGHT PIPES
OPEN TOP

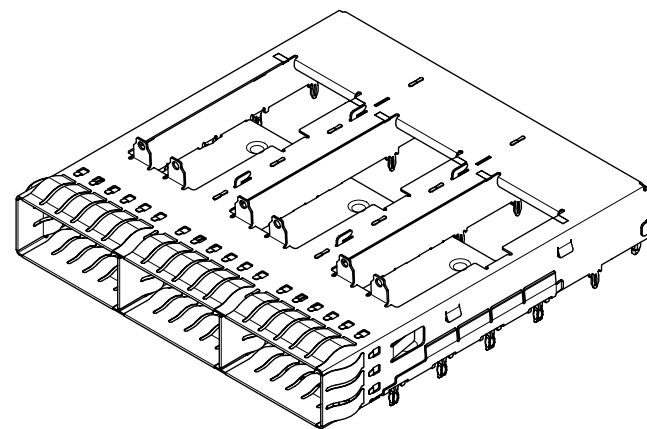

| MOLEX P/N W/ SPRING FINGERS | #OF REAR LEGS PER PORT |
|--------------------------------|---------------------------|
| 1000163252 | 1 |

WITH HEATSINKS
NO LIGHT PIPES

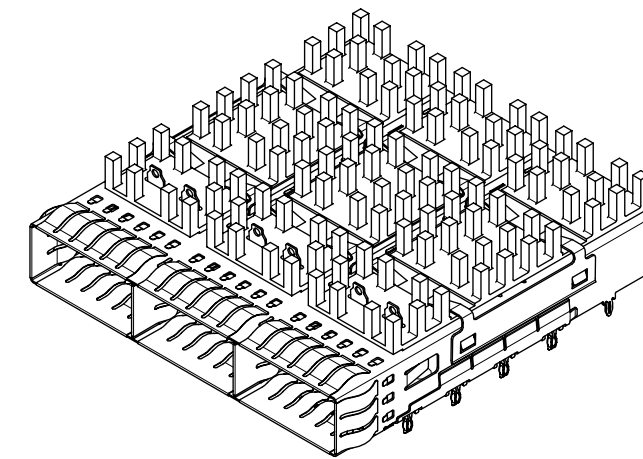

| MOLEX P/N | HEATSINKS | #OF REAR LEGS PER PORT |
|------------|-----------|---------------------------|
| 1000163340 | PCI | 0 |
| 1000163345 | NET | 1 |

WITH HEATSINKS AND LIGHT PIPES

| MOLEX P/N | LIGHTPIPES | HEATSINKS | #OF REAR LEGS PER PORT | DIM "B" |
|------------|------------|-----------|---------------------------|-----------|
| 1000163547 | QUAD | SAN | 1 | 61.07 REF |

QUAD LIGHT PIPE

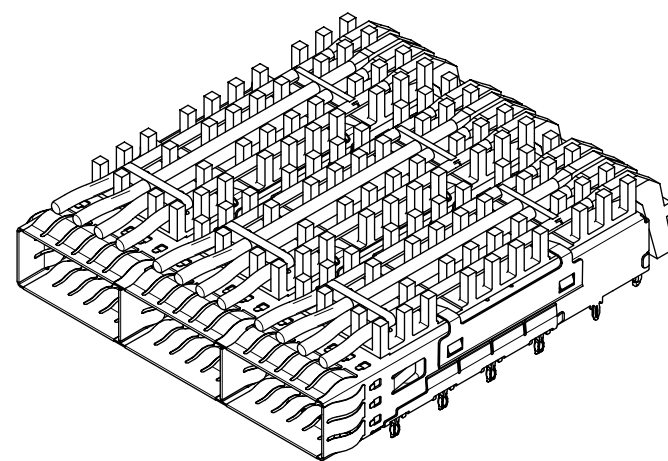

| | | | | | | |
|--|---|--|---|---|---|---|
| FUNCTIONAL SYMBOLS $\nabla_A = 0$ $\nabla_C = 0$ $\nabla_P = 0$ | THIS DRAWING CONTAINS INFORMATION THAT IS PROPRIETARY TO MOLEX ELECTRONIC TECHNOLOGIES, LLC AND SHOULD NOT BE USED WITHOUT WRITTEN PERMISSION | | CURRENT REV DESC: SEE REV TABLE | | <p>QZSFP+ 1X3 GANGED CAGE ASSY'S W/ SUS TAB TYPE SPRING FINGER, H/S & L/P OPTIONS</p> <p>PRODUCT CUSTOMER DRAWING</p> | |
| | DIMENSION UNITS: mm SCALE: 1:1 | GENERAL TOLERANCES (UNLESS SPECIFIED) ANGULAR TOL $\pm 2.0^\circ$ | | EC NO: 698867 DRWN: VISHNM2 2022/02/22 CHK'D: TKUMARKC 2022/03/16 APPR: JCHIANG 2022/03/17 | | |
| DIVISIONAL SYMBOLS 4 PLACES \pm 3 PLACES \pm 2 PLACES ± 0.13 1 PLACE ± 0.25 0 PLACES \pm | DRAFT WHERE APPLICABLE MUST REMAIN WITHIN DIMENSIONS | | INITIAL REVISION: DRWN: VISHNM2 2022/02/22 APPR: JCHIANG 2022/03/17 | DOCUMENT NUMBER: 1000163200 | | DOC TYPE: PSD DOC PART: ASY REVISION: A |
| THIRD ANGLE PROJECTION | DRAWING: C-SIZE | SERIES: 100016 | MATERIAL NUMBER: SEE P/N TABLE CUSTOMER: GENERAL MARKET | SHEET NUMBER: 3 OF 7 | | |

PCB LAYOUT FOR SINGLE SIDED MOUNTING

HATCHED AREA DENOTES COMPONENT AND TRACE KEEP-OUT (EXCEPT CHASSIS GROUND)

Ø 1.05 ± 0.05 TYP
 ⊕ Ø 0.10 (M) A K L

AREA DENOTES COMPONENT KEEP-OUT (TRACES ALLOWED)

DATUM -A- IS THE TOP SURFACE OF HOST BOARD

CROSS HATCHED AREA DENOTES WHERE SURFACE TRACES ARE PERMITTED

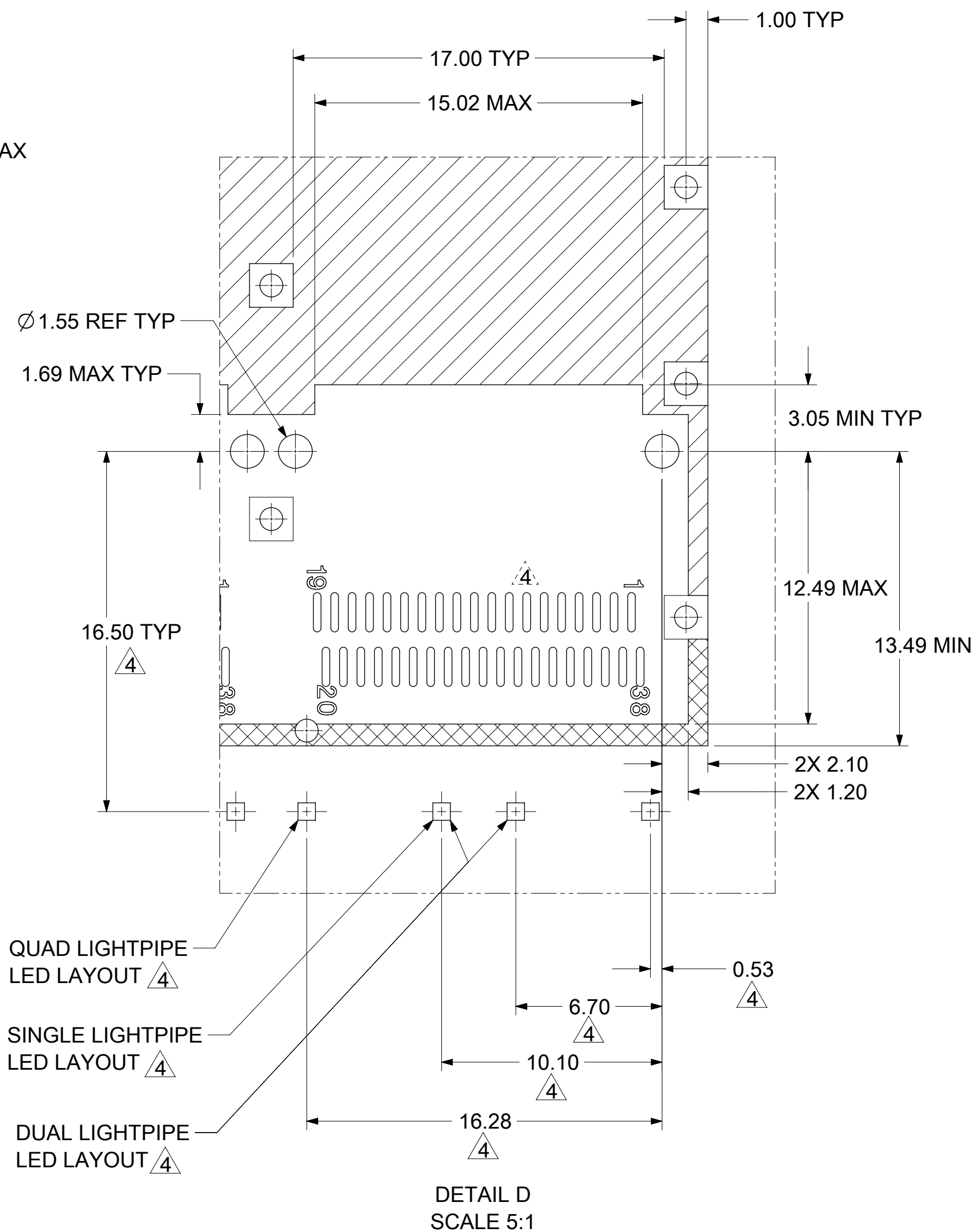
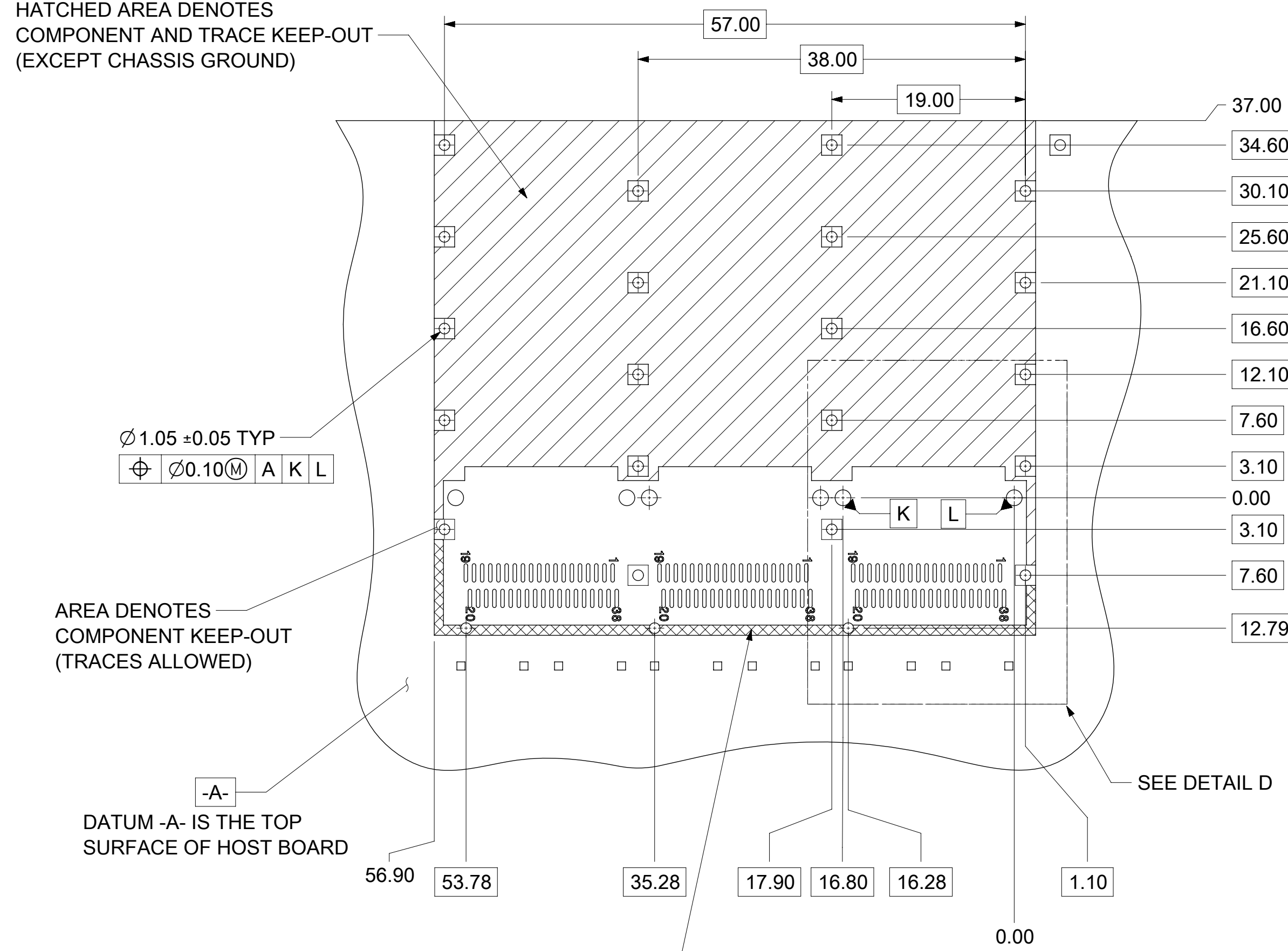

DETAIL D
SCALE 5:1

- NOTES:
- PADS AND VIAS GO TO CHASSIS GROUND. (RECOMMENDED PADS TO BE 2.00mm SQUARE.)
 - RECOMMENDED THRU HOLE PLATING INCLUDES HASL, OSP, OR IMMERSION (GOLD, SILVER, OR TIN).
 - CONNECTOR PAD LAYOUT PER SFF-8663 WILL ACCOMODATE MOLEX CONNECTOR SERIES 170432.
- ⚠ NOTED DIMENSIONS ONLY APPLY TO CAGE ASSEMBLIES WITH LIGHT PIPES.

| | | | | | |
|--------------------|---|--------|---------------------------------|------------|--|
| FUNCTIONAL SYMBOLS | THIS DRAWING CONTAINS INFORMATION THAT IS PROPRIETARY TO MOLEX ELECTRONIC TECHNOLOGIES, LLC AND SHOULD NOT BE USED WITHOUT WRITTEN PERMISSION | | CURRENT REV DESC: SEE REV TABLE | | |
| | DIMENSION UNITS | SCALE | | | |
| ▽A = 0 | mm | 3.5:1 | | | ZQSFP+ 1X3 GANGED CAGE ASSY'S W/ SUS TAB TYPE SPRING FINGER, H/S & L/P OPTIONS |
| ▽C = 0 | GENERAL TOLERANCES (UNLESS SPECIFIED) | | | | |
| ▽P = 0 | ANGULAR TOL ± 2.0° | | | | PRODUCT CUSTOMER DRAWING |
| DIVISIONAL SYMBOLS | 4 PLACES | ± | EC NO: 698867 | 2022/02/22 | |
| | 3 PLACES | ± | DRWN: VISHNM2 | 2022/03/16 | |
| | 2 PLACES | ± 0.13 | CHK'D: TKUMARKC | 2022/03/17 | |
| | 1 PLACE | ± 0.25 | APPR: JCHIANG | | |
| | 0 PLACES | ± | INITIAL REVISION: | | |
| | DRAFT WHERE APPLICABLE MUST REMAIN WITHIN DIMENSIONS | | DRWN: VISHNM2 | 2022/02/22 | DOCUMENT NUMBER |
| | THIRD ANGLE PROJECTION | | APPR: JCHIANG | 2022/03/17 | 1000163200 |
| | DRAWING SERIES | | C-SIZE | 100016 | DOC TYPE DOC PART REVISION |
| | | | | | PSD ASY A |
| | | | | | MATERIAL NUMBER CUSTOMER SHEET NUMBER |
| | | | | | GENERAL MARKET 4 OF 7 |

PCB LAYOUT FOR BELLY TO BELLY MOUNTING

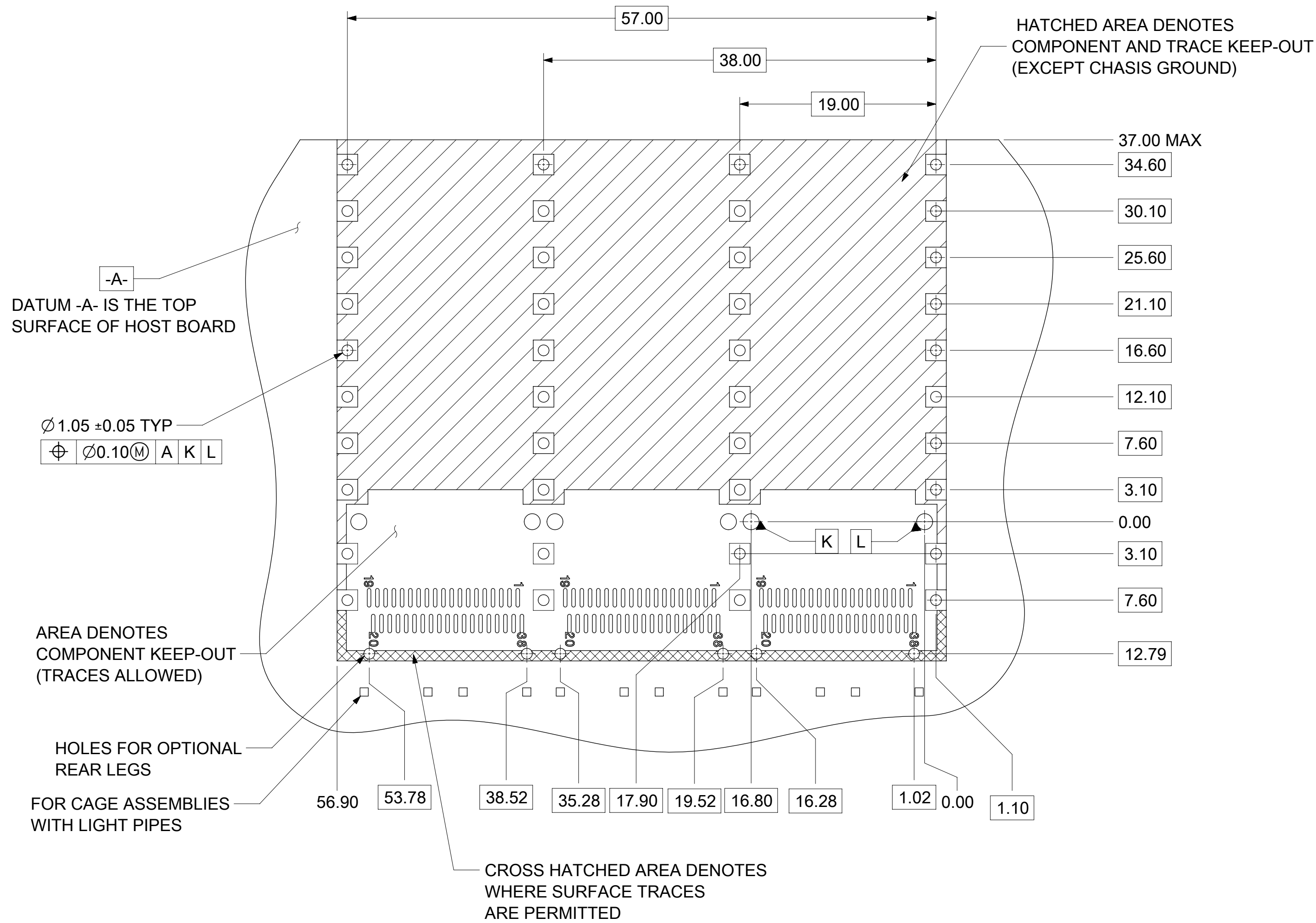

- NOTES:
1. PADS AND VIAS GO TO CHASSIS GROUND. (RECOMMENDED PADS TO BE 2.00mm SQUARE.)
 2. RECOMMENDED THRU HOLE PLATING INCLUDES HASL, OSP, OR IMMERSION (GOLD, SILVER, OR TIN).
 3. CONNECTOR PAD LAYOUT PER SFF-8663 WILL ACCOMODATE MOLEX CONNECTOR SERRIES 170432.

| | | | | |
|--|---|----------------|---------------------------------|-----------------|
| FUNCTIONAL SYMBOLS | THIS DRAWING CONTAINS INFORMATION THAT IS PROPRIETARY TO MOLEX ELECTRONIC TECHNOLOGIES, LLC AND SHOULD NOT BE USED WITHOUT WRITTEN PERMISSION | | CURRENT REV DESC: SEE REV TABLE | |
| | DIMENSION UNITS | SCALE | | |
| $\frac{F}{A} = 0$ | mm | 3:1 | | |
| $\frac{F}{C} = 0$ | GENERAL TOLERANCES (UNLESS SPECIFIED) | | EC NO: 698867 | |
| | ANGULAR TOL $\pm 2.0^\circ$ | | DRWN: VISHNM2 | 2022/02/22 |
| $\frac{F}{P} = 0$ | 4 PLACES | \pm | CHK'D: TKUMARKC | 2022/03/16 |
| | 3 PLACES | \pm | APPR: JCHIANG | 2022/03/17 |
| DIVISIONAL SYMBOLS | 2 PLACES | ± 0.13 | INITIAL REVISION: | |
| | 1 PLACE | ± 0.25 | DRWN: VISHNM2 | 2022/02/22 |
| | 0 PLACES | \pm | APPR: JCHIANG | 2022/03/17 |
| DRAFT WHERE APPLICABLE MUST REMAIN WITHIN DIMENSIONS | THIRD ANGLE PROJECTION | DRAWING | SERIES | MATERIAL NUMBER |
| | | C-SIZE | 100016 | SEE P/N TABLE |
| | | CUSTOMER | SHEET NUMBER | |
| | | GENERAL MARKET | 5 OF 7 | |

molex

ZQSFP+ 1X3 GANGED CAGE ASSY'S
W/ SUS TAB TYPE SPRING FINGER, H/S & L/P
OPTIONS

PRODUCT CUSTOMER DRAWING

DOCUMENT NUMBER DOC TYPE DOC PART REVISION

1000163200 PSD ASY A

SEE P/N TABLE GENERAL MARKET

DOCUMENT STATUS P1 RELEASE DATE 2022/03/17 10:10:57

BEZEL AND BOARD POSITION DIMENSIONS FOR BELLY TO BELLY MOUNTING

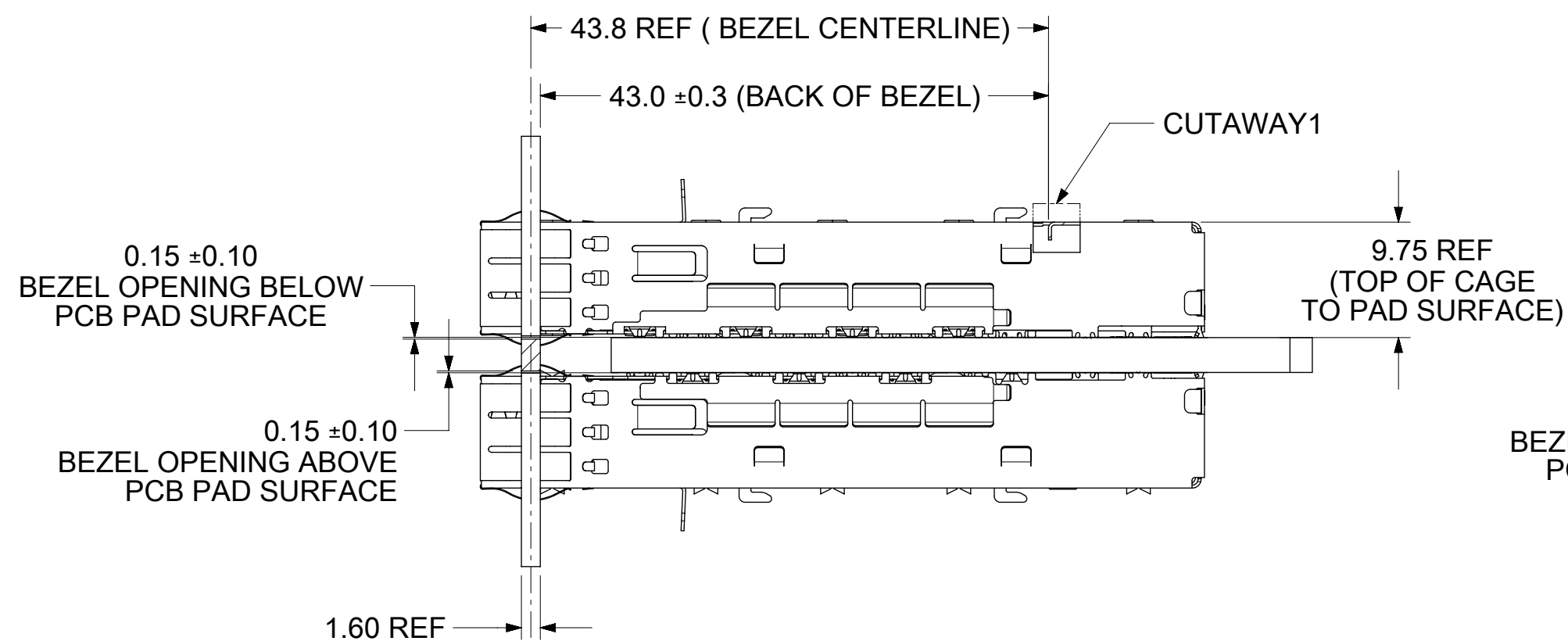

BEZEL AND BOARD POSITION DIMENSIONS FOR SINGLE SIDE MOUNTING

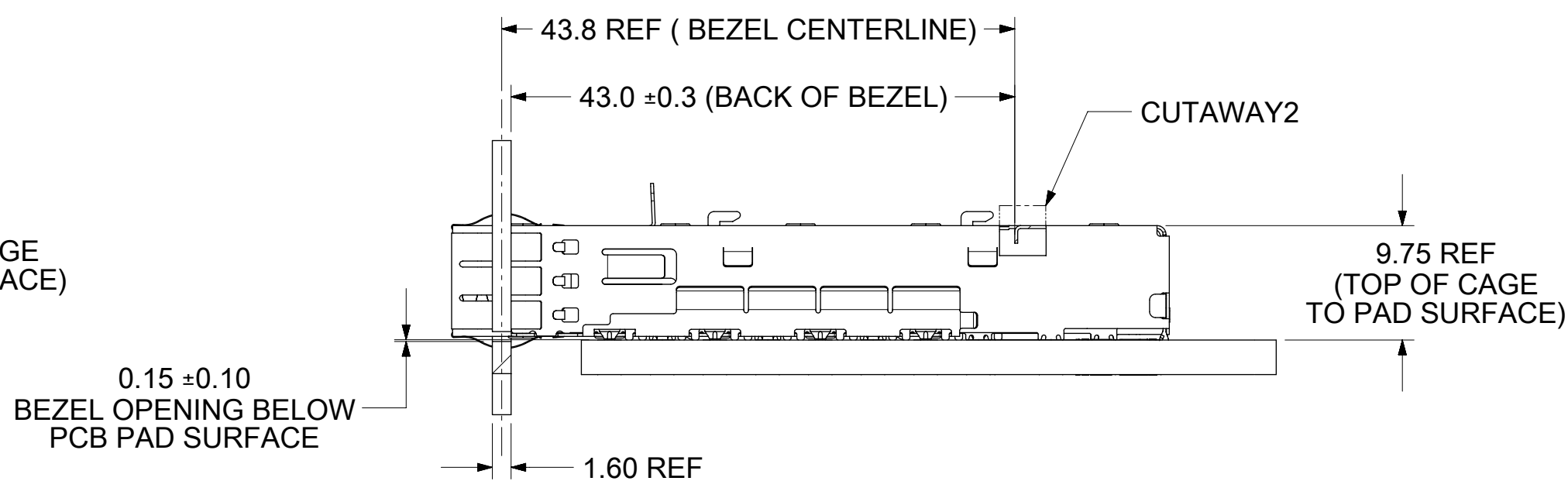

DUAL/QUAD LIGHT PIPE ²

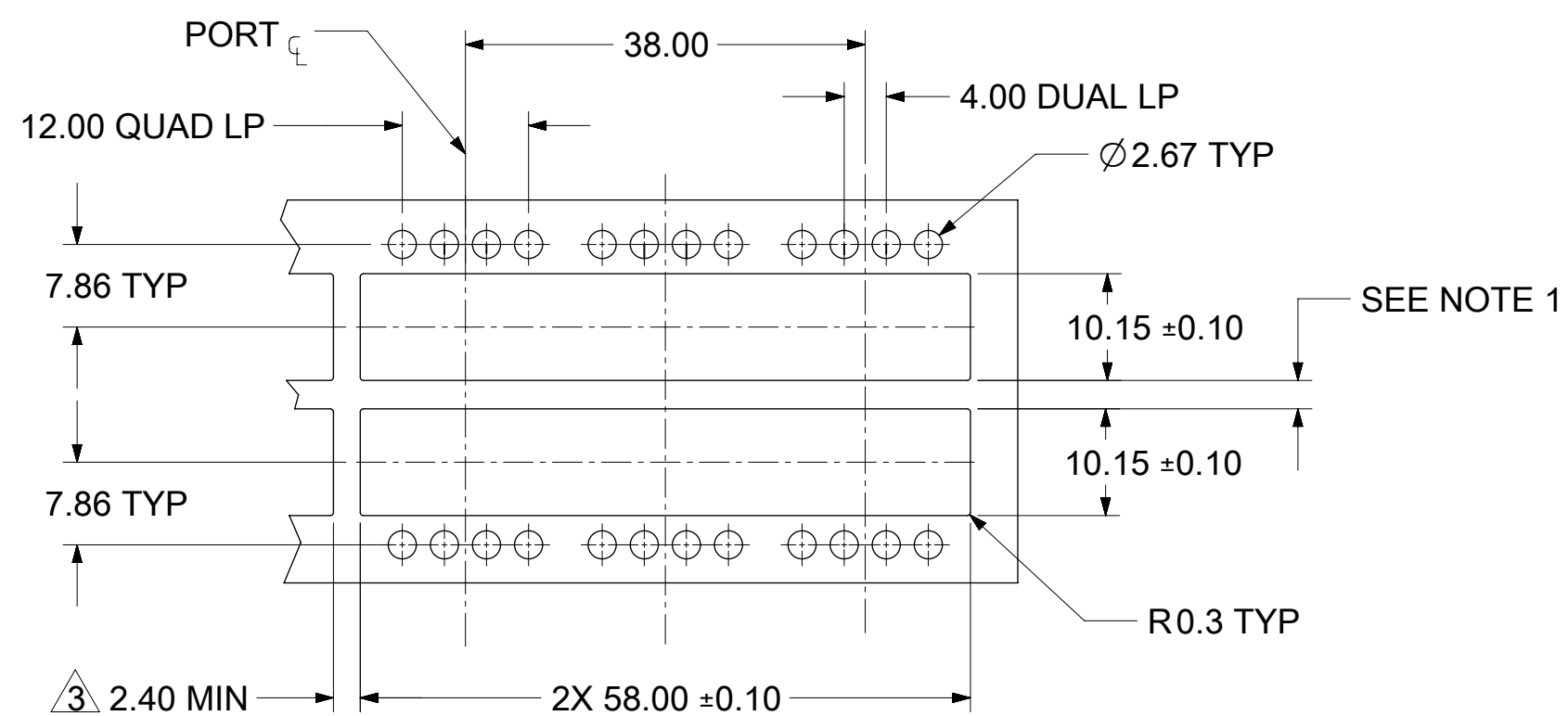

DUAL LIGHT PIPE ²

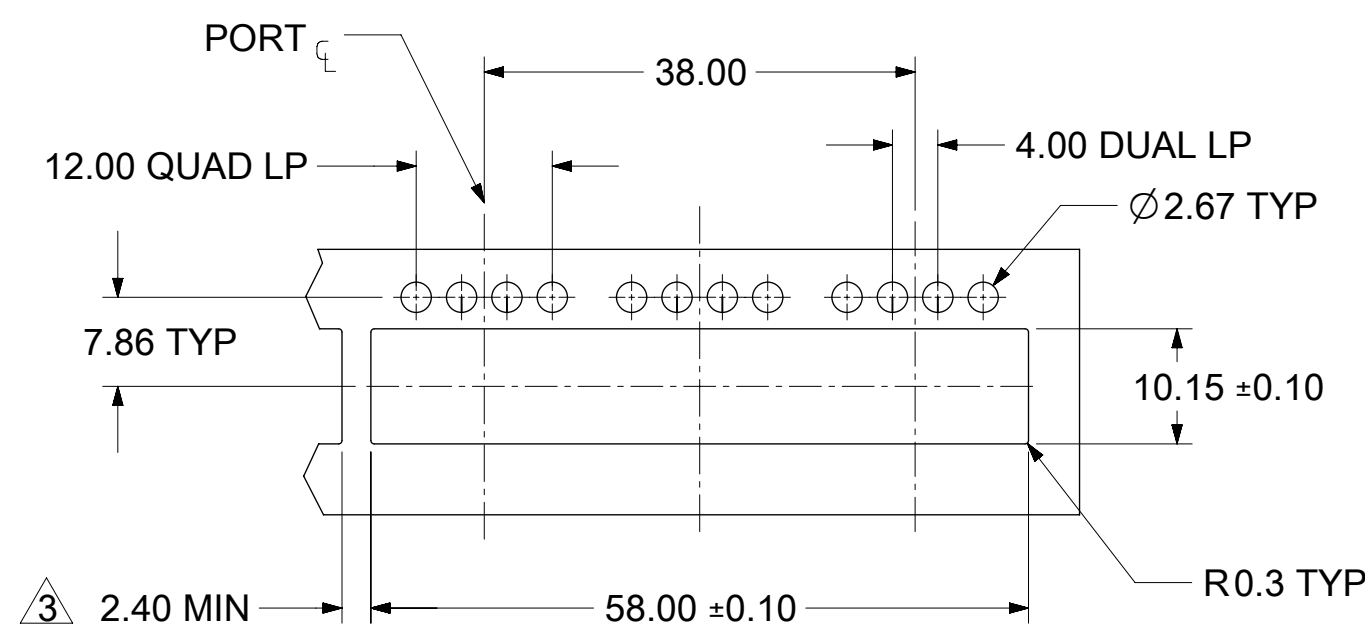

- NOTE:**
1. PCB THICKNESS VARIATION MUST BE CONSIDERED WHEN DETERMINING BEZEL OPENING LOCATION.
 2. NOTED DIMENSIONS ONLY APPLY TO CAGE ASSEMBLIES WITH LIGHT PIPES.
 3. THIS DIMENSION IS FOR REFERENCE ONLY. USER CAN MODIFY IT DEPENDS ON APPLICATION. (THIS DIMENSION VARIES BASED ON DISTANCE OF " HOLE OF ADIACENT CAGE" ON PCB LAYOUT.)

| | | | | | | | |
|--|---|------------|---------------------------------|-----------------|-----------------|--------------|----------|
| FUNCTIONAL SYMBOLS | THIS DRAWING CONTAINS INFORMATION THAT IS PROPRIETARY TO MOLEX ELECTRONIC TECHNOLOGIES, LLC AND SHOULD NOT BE USED WITHOUT WRITTEN PERMISSION | | CURRENT REV DESC: SEE REV TABLE | | | | |
| | DIMENSION UNITS | SCALE | EC NO: 698867 | | | | |
| $\frac{E}{A} = 0$ | mm | 2:1 | DRWN: VISHNM2 | | 2022/02/22 | | |
| $\frac{E}{C} = 0$ | GENERAL TOLERANCES (UNLESS SPECIFIED) | | CHK'D: TKUMARKC | | 2022/03/16 | | |
| $\frac{E}{P} = 0$ | ANGULAR TOL ± 2.0° | | APPR: JCHIANG | | 2022/03/17 | | |
| DIVISIONAL SYMBOLS | 4 PLACES | ± | INITIAL REVISION: | | DOCUMENT NUMBER | | |
| | 3 PLACES | ± | DRWN: VISHNM2 | | 1000163200 | | DOC TYPE |
| | 2 PLACES | ± 0.13 | APPR: JCHIANG | | PSD | | DOC PART |
| | 1 PLACE | ± 0.25 | 2022/02/22 | | ASY | | REVISION |
| 0 PLACES | ± | 2022/03/17 | | A | | | |
| DRAFT WHERE APPLICABLE MUST REMAIN WITHIN DIMENSIONS | THIRD ANGLE PROJECTION | DRAWING | SERIES | MATERIAL NUMBER | CUSTOMER | SHEET NUMBER | |
| | | C-SIZE | 100016 | SEE P/N TABLE | GENERAL MARKET | 6 OF 7 | |

| REV | DATE | DESCRIPTION |
|-----|------------|-------------|
| A | 2022/02/22 | RELEASE |
| | | |
| | | |
| | | |
| | | |
| | | |
| | | |
| | | |

H
G
F
E
D
C
B
A

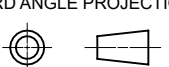
| | | | | | | | | | | | | | | | |
|--------------------|---|--------|--|--|--|--|--|--|--|---|--|-----------------|-----|--------------|----------|
| FUNCTIONAL SYMBOLS | THIS DRAWING CONTAINS INFORMATION THAT IS PROPRIETARY TO MOLEX ELECTRONIC TECHNOLOGIES, LLC AND SHOULD NOT BE USED WITHOUT WRITTEN PERMISSION | | | | | | | | | | | | | | |
| | DIMENSION UNITS | SCALE | CURRENT REV DESC: SEE REV TABLE | | | | | | |  | | | | | |
| $\frac{F}{A} = 0$ | mm | 1:1 | EC NO: 698867 DRWN: VISHNM2 2022/02/22 CHK'D: TKUMARKC 2022/03/16 APPR: JCHIANG 2022/03/17 INITIAL REVISION: DRWN: VISHNM2 2022/02/22 APPR: JCHIANG 2022/03/17 | | | | | | | | | DOCUMENT NUMBER | | DOC TYPE | DOC PART |
| $\frac{F}{C} = 0$ | GENERAL TOLERANCES (UNLESS SPECIFIED) | | | | | | | | | 1000163200 | | PSD | ASY | A | |
| $\frac{F}{P} = 0$ | ANGULAR TOL ± 2.0° | | | | | | | | | SEE P/N TABLE | | GENERAL MARKET | | SHEET NUMBER | |
| DIVISIONAL SYMBOLS | 4 PLACES | ± | THIRD ANGLE PROJECTION | | | | | | | MATERIAL NUMBER | | CUSTOMER | | SHEET NUMBER | |
| | 3 PLACES | ± |  | | | | | | | 100016 | | GENERAL MARKET | | 7 OF 7 | |
| | 2 PLACES | ± 0.13 | DRAWING | | | | | | | C-SIZE | | SERIES | | 100016 | |
| | 1 PLACE | ± 0.25 | DRAFT WHERE APPLICABLE MUST REMAIN WITHIN DIMENSIONS | | | | | | | SEE P/N TABLE | | GENERAL MARKET | | 7 OF 7 | |
| | 0 PLACES | ± | | | | | | | | | | | | | |