

1

2

3

4

5

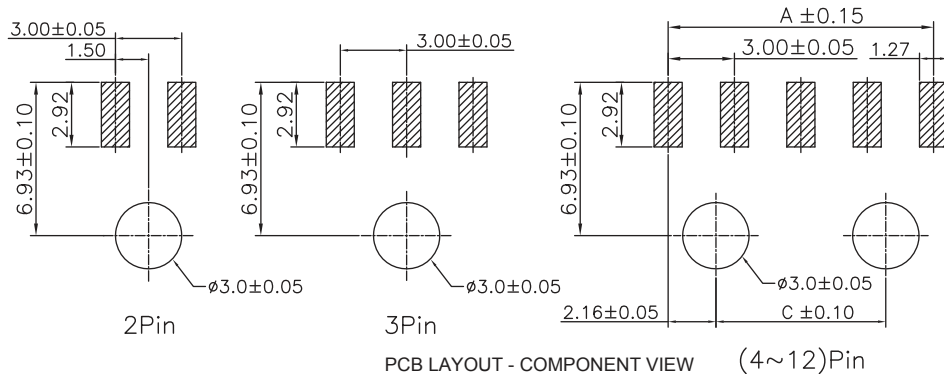

PCB LAYOUT - COMPONENT VIEW (4~12)Pin

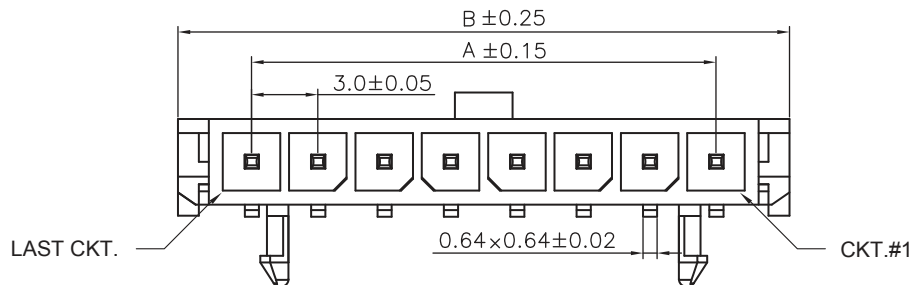
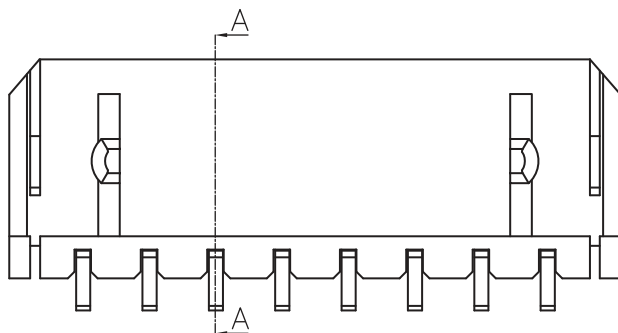
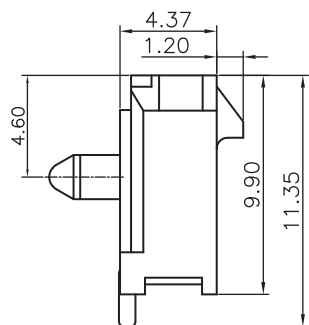

## TECHNICAL CHARACTERISTICS

MATERIAL  
 INSULATOR: LCP  
 FLAMABILITY RATING: UL94-V0  
 COLOR: BLACK  
 CONTACT MATERIAL: COPPER ALLOY  
 CONTACT TYPE: STAMPED  
 CONTACT PLATING: TIN  
 QUALITY CLASS: 25 MATING CYCLES  
 PITCH: 3.00MM

ENVIRONMENTAL  
 OPERATING TEMPERATURE: -40 UP TO 105 °C  
 COMPLIANCE: LEAD FREE AND ROHS

ELECTRICAL  
 CURRENT RATING: 5A  
 WORKING VOLTAGE: 250 VAC  
 INSULATOR RESISTANCE: >1000 MOHM  
 DIELECTRIC WITHSTANDING VOLTAGE: 1500 VAC/MN  
 CONTACT RESISTANCE: 10 mOHM MAX

STANDARD  
 CERTIFIED: E323964

SOLDERING  
 JEDEC LEAD FREE REFLOW SOLDERING PROCESS

PACKAGING  
 TAPE AND REEL

DIMENSION  
 A = 3.00 x (NB. PIN -1)  
 B = 3.00 x (NB. PIN +1) +0.65  
 C = 3.00 x (NB. PIN -3) +1.7

RoHS Compliant

PROJECTION:



GENERAL TOLERANCE

.X = +/- 0.2

.XX = +/- 0.15



APPROVAL: BBu

UNIT: MM

SCALE:

SHEET: 1/3

DRAW: AK

DESCRIPTION: 3.00 MM SMT SINGLE ROW MALE RIGHT ANGLED HEADER  
 WITH SNAP-IN PLASTIC PEGS

WERI PART NO: 662 1xx 136 022

SIZE

A4

F			
E			
D			
C			
B			
A	13-JUL-15	PDF	AK
REV	DATE	FILE	BY

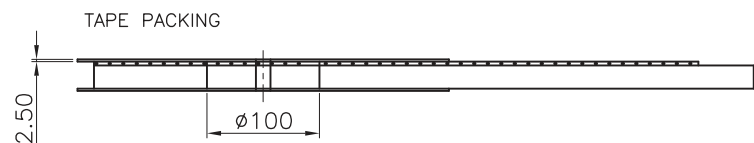
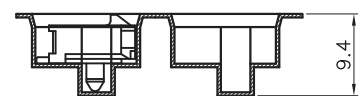
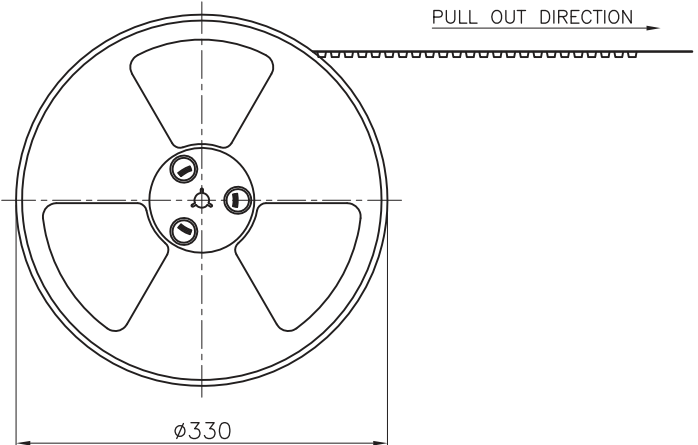

Pin No	W	F	PCS/R	R/CTN	Q'TY
02	24	11.5	400	9	3600
03-04	32	14.2	400	7	2800
05-08	44	20.2	400	5	2000
09-12	56	26.2	400	4	1600

Note:  
 1.All dimensions meet EIA-481-3 requirements.  
 2.Material: BK Conductive Polystyrene Alloy  
 100% recyclable.  
 3.Thickness : 0.40±0.05mm  
 4.Carton Size:350\*350\*296(mm)

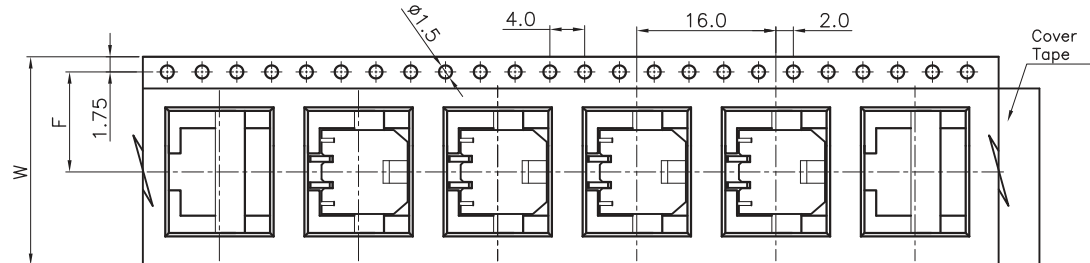
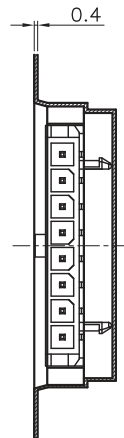
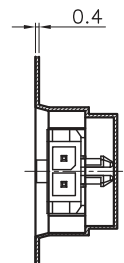

Pull Out Direction  
 For Reel width (dimension W)24mm Single row hole

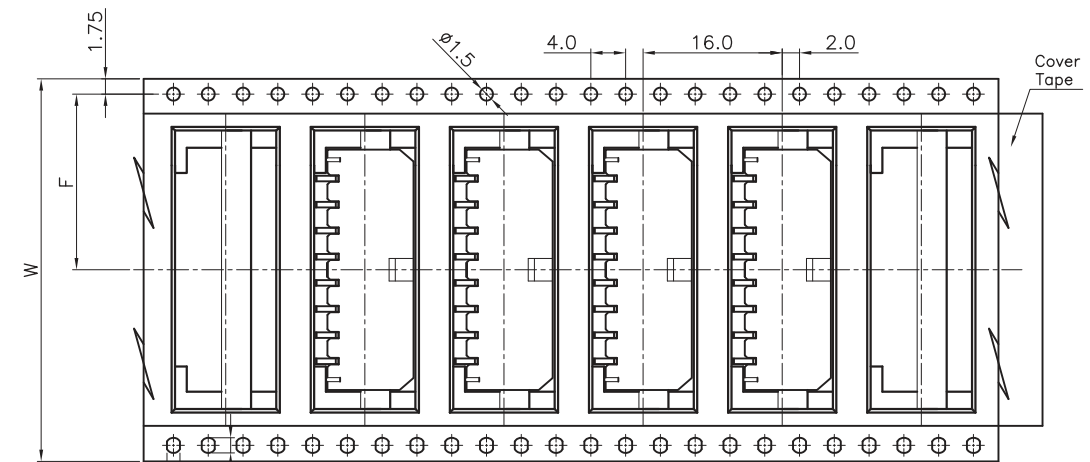

Pull Out Direction  
 For Reel width (dimension W)32,44,56MM Double rows hole

RoHS Compliant				PROJECTION:	GENERAL TOLERANCE		DESCRIPTION: 3.00 MM SMT SINGLE ROW MALE RIGHT ANGLED HEADER WITH SNAP-IN PLASTIC PEGS WERI PART NO: 662 1xx 136 022	SIZE <b>A4</b>
F					.X = +/- 0.2			
E					.XX = +/- 0.15			
D				APPROVAL: BBu	UNIT: MM	<b>A4</b>		
C					SCALE:			
B					SHEET: 2/3			
A					DRAW: AK			
REV	DATE	FILE	BY					

1

2

3

4

5

## Cautions and Warnings:

This electronic component is designed and developed with the intention for use in general electronics equipments.



Before incorporating the components into any equipments in the field such as aerospace, aviation, nuclear control, submarine, transportation, (automotive control, train control, ship control), transportation signal, disaster prevention, medical, public information network etc. where higher safety and reliability are especially required or if there is possibility of direct damage or injury to human body, Würth Elektronik must be asked for a written approval.

In addition, even electronic component in general electronic equipments, when used in electrical circuits that require high safety, reliability functions or performance, the sufficient reliability evaluation-check for the safety must be performed before by the user before usage.

A

B

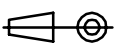
C

RoHS Compliant				PROJECTION: 	GENERAL TOLERANCE .X = +/- 0.2 .XX = +/- 0.15		DESCRIPTION: DISCLAIMER	SIZE <b>A4</b>
G								
F								
E								
D								
C				APPROVAL: JC	UNIT: MM	WERI PART NO: DISCLAIMER	SIZE <b>A4</b>	
B					SCALE:			
A	10-SEP-14	PDF	QL		SHEET: 3/3			
REV	DATE	FILE	BY		DRAW: QL			

D