

SOT23 NPN SILICON PLANAR SWITCHING TRANSISTORS

FMMT2222
FMMT2222A

ISSUE 3 – FEBRUARY 1996

FEATURES

* Fast switching

PARTMARKING DETAILS

FMMT2222 – 1BZ FMMT2222A – 1P

FMMT2222R – 2P FMMT2222AR – 3P

COMPLEMENTARY TYPES

FMMT2222 – FMMT2907

FMMT2222A – FMMT2907A

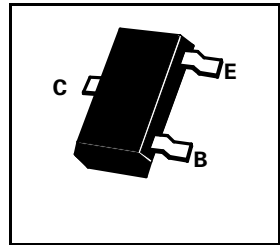

ABSOLUTE MAXIMUM RATINGS.

PARAMETER	SYMBOL	FMMT2222	FMMT2222A	UNIT
Collector-Base Voltage	V_{CBO}	60	75	V
Collector-Emitter Voltage	V_{CEO}	30	40	V
Emitter-Base Voltage	V_{EBO}	5	6	V
Continuous Collector Current	I_C	600		mA
Power Dissipation at $T_{amb}=25^{\circ}C$	P_{tot}	330		mW
Operating and Storage Temperature Range	T_j, T_{stg}	-55 to +150		$^{\circ}C$

ELECTRICAL CHARACTERISTICS (at $T_{amb} = 25^{\circ}C$ unless otherwise stated).

PARAMETER	SYMBOL	FMMT2222		FMMT2222A		UNIT	CONDITIONS.
		MIN.	MAX.	MIN.	MAX.		
Collector-Base Breakdown Voltage	$V_{(BR)CBO}$	60		75		V	$I_C=10\mu A, I_E=0$
Collector-Emitter Breakdown Voltage	$V_{(BR)CEO}$	30		40		V	$I_C=10mA, I_B=0$
Emitter-Base Breakdown Voltage	$V_{(BR)EBO}$	5		6		V	$I_E=10\mu A, I_C=0$
Collector Cut-Off Current	I_{CBO}		10		10	nA	$V_{CB}=50V, I_E=0$
			10		10	μA	$V_{CB}=60V, I_E=0$
					10	nA	$V_{CB}=50V, I_E=0, T_{amb}=150^{\circ}C$
					10	μA	$V_{CB}=60V, I_E=0, T_{amb}=150^{\circ}C$
Emitter Cut-Off Current	I_{EBO}		10		10	nA	$V_{EB}=3V, I_C=0$
Collector-Emitter Cut-Off Current	I_{CEX}		10		10	nA	$V_{CE}=60V, V_{EB(off)}=3V$
Collector-Emitter Saturation Voltage	$V_{CE(sat)}$		0.3		0.3	V	$I_C=150mA, I_B=15mA^*$
			1.0		1.0	V	$I_C=500mA, I_B=50mA^*$
Base-Emitter Saturation Voltage	$V_{BE(sat)}$	0.6	2.0	0.6	1.2	V	$I_C=150mA, I_B=15mA^*$
			2.6		2.0	V	$I_C=500mA, I_B=50mA^*$
Static Forward Current Transfer Ratio	h_{FE}	35		35			$I_C=0.1mA, V_{CE}=10V^*$
		50		50			$I_C=1mA, V_{CE}=10V$
		75		75			$I_C=10mA, V_{CE}=10V^*$
		35		35			$I_C=10mA, V_{CE}=10V, T_{amb}=-55^{\circ}C$
		100	300	100	300		$I_C=150mA, V_{CE}=10V^*$
		50		50			$I_C=150mA, V_{CE}=1V^*$
		30		40			$I_C=500mA, V_{CE}=10V^*$

*Measured under pulsed conditions. Pulse width=300 μs . Duty cycle $\leq 2\%$
Spice parameter data is available upon request for this device

FMMT2222

FMMT2222A

ELECTRICAL CHARACTERISTICS (at $T_{amb} = 25^{\circ}\text{C}$ unless otherwise stated).

PARAMETER	SYMBOL	FMMT2222		FMMT2222A		UNIT	CONDITIONS.
		MIN.	MAX.	MIN.	MAX.		
Transition Frequency	f_T	250		300		MHz	$I_C=20\text{mA}$, $V_{CE}=20\text{V}$ $f=100\text{MHz}$
Output Capacitance	C_{obo}		8		8	pF	$V_{CB}=10\text{V}$, $I_E=0$, $f=140\text{KHz}$
Input Capacitance	C_{ibo}		30		25	pF	$V_{EB}=0.5\text{V}$, $I_C=0$ $f=140\text{KHz}$
Delay Time	t_d		10		10	ns	$V_{CC}=30\text{V}$, $V_{BE(off)}=0.5\text{V}$ $I_C=150\text{mA}$, $I_{B1}=15\text{mA}$ (See Delay Test Circuit)
Rise Time	t_r		25		25	ns	
Storage Time	t_s		225		225	ns	$V_{CC}=30\text{V}$, $I_C=150\text{mA}$ $I_{B1}=I_{B2}=15\text{mA}$ (See Storage Test Circuit)
Fall Time	t_f		60		60	ns	

DELAY AND RISE – TEST CIRCUIT

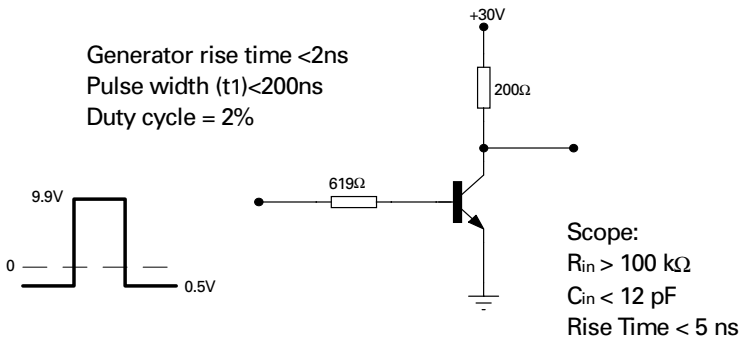

STORAGE TIME AND FALL TIME – TEST CIRCUIT

