

注記 NOTES

- 梱包数量：900個/リール
NUMBER OF CONNECTORS:900 PCS/REEL
- リードテープ長さ
LEAD TAPE LENGTH

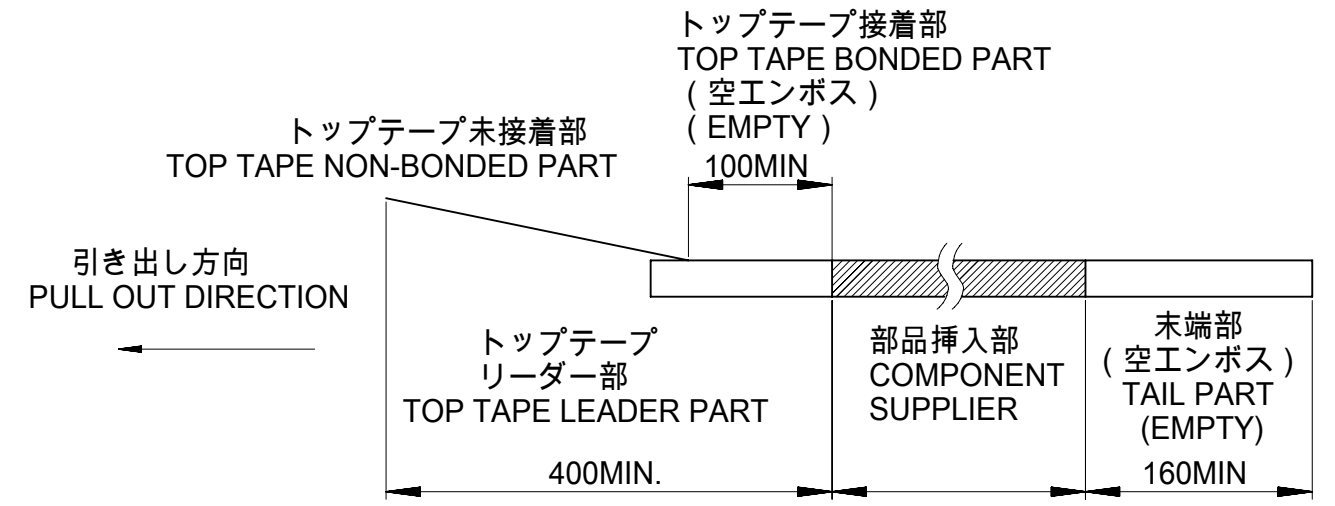

- トップテープの剥離強度については、IEC60286-3に準拠。
TOP TAPE PEEL FORCE IS DEFINED BY IEC60286-3.
- 製品詳細寸法については図面 5017861002 DOC. PART 000を参照下さい。
RE DETAILED DIMENSION, SEE 5017861002 DOC. PART 000.
- 材料(MATERIAL)
キャリアテープ(CARRIER TAPE)：ポリスチレン(POLYSTYRENE)
トップテープ(TOP TAPE)：PET, PE, PE
リール(REEL)：ポリスチレン(POLYSTYRENE)
リサイクル材を含む
RECYCLE MATERIAL CONTAINED

56	56.0	52.4	26.2	61.4	57.4	25.68	33.3	5017865091	50
44	44.0	40.4	20.2	49.4	45.4	20.68	28.3	5017864091	40
						15.68	23.3	5017863091	30
キャリアテープ幅 CARRIER TAPE WIDTH	G	F	E	D	C	B	A	EMBOSSED PACKAGE オーダー番号 ORDER No.	Circuit

THIS DRAWING CONTAINS INFORMATION THAT IS PROPRIETARY TO MOLEX ELECTRONIC TECHNOLOGIES, LLC AND SHOULD NOT BE USED WITHOUT WRITTEN PERMISSION

DIMENSION UNITS mm	SCALE 1:1	CURRENT REV DESC:	molex		
GENERAL TOLERANCES (UNLESS SPECIFIED)		EC NO: 628512	EMBSTP PKG FOR 0.5 FFC TO BOARD ST TYPE		
ANGULAR TOL	± 3.0°	DRWN: SKITAZAWA 2020/02/04	PRODUCT CUSTOMER DRAWING		
4 PLACES	± 0.2	CHK'D: HSHIMOYAMA 2020/02/04	DOCUMENT NUMBER		
3 PLACES	± 0.2	APPR: SHOSHIKAWA 2020/02/04	DOC TYPE		
2 PLACES	± 0.25	INITIAL REVISION:	DOC PART		
1 PLACE	± 0.3	DRWN: VLM 2016/02/17	REVISION		
0 PLACES	± 0.3	APPR: TKUSUHARA01 2017/04/28	5017860002		
DRAFT WHERE APPLICABLE MUST REMAIN WITHIN DIMENSIONS	THIRD ANGLE PROJECTION	DRAWING A3-SIZE	SERIES 501786	MATERIAL NUMBER SEE CHART	CUSTOMER GENERAL MARKET

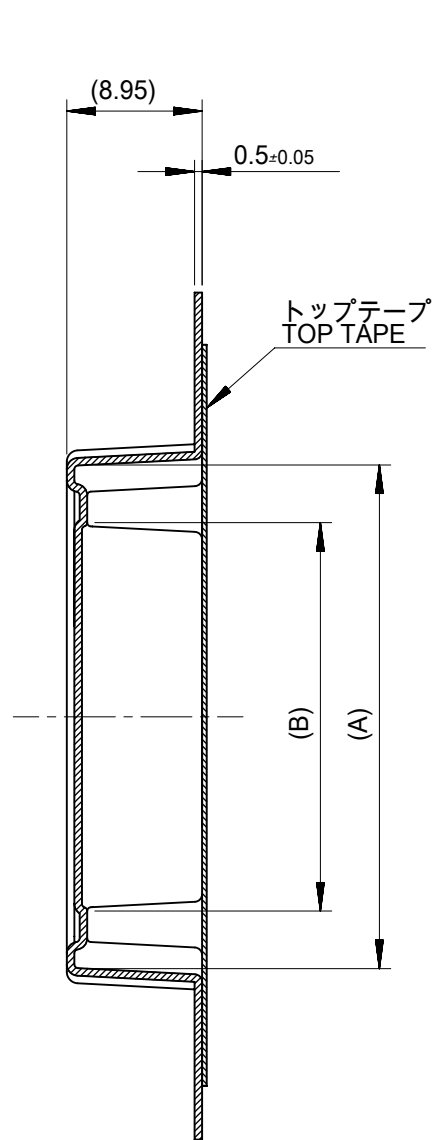

SECT. Y-Y

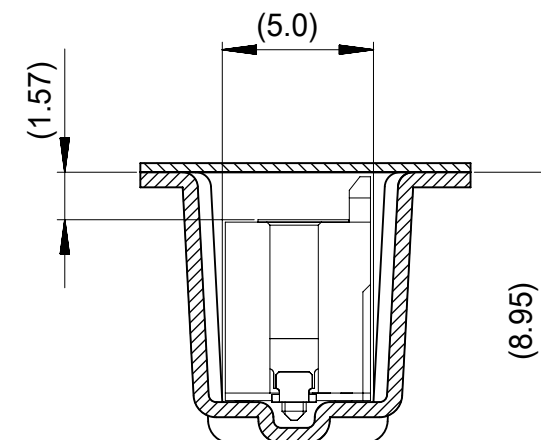
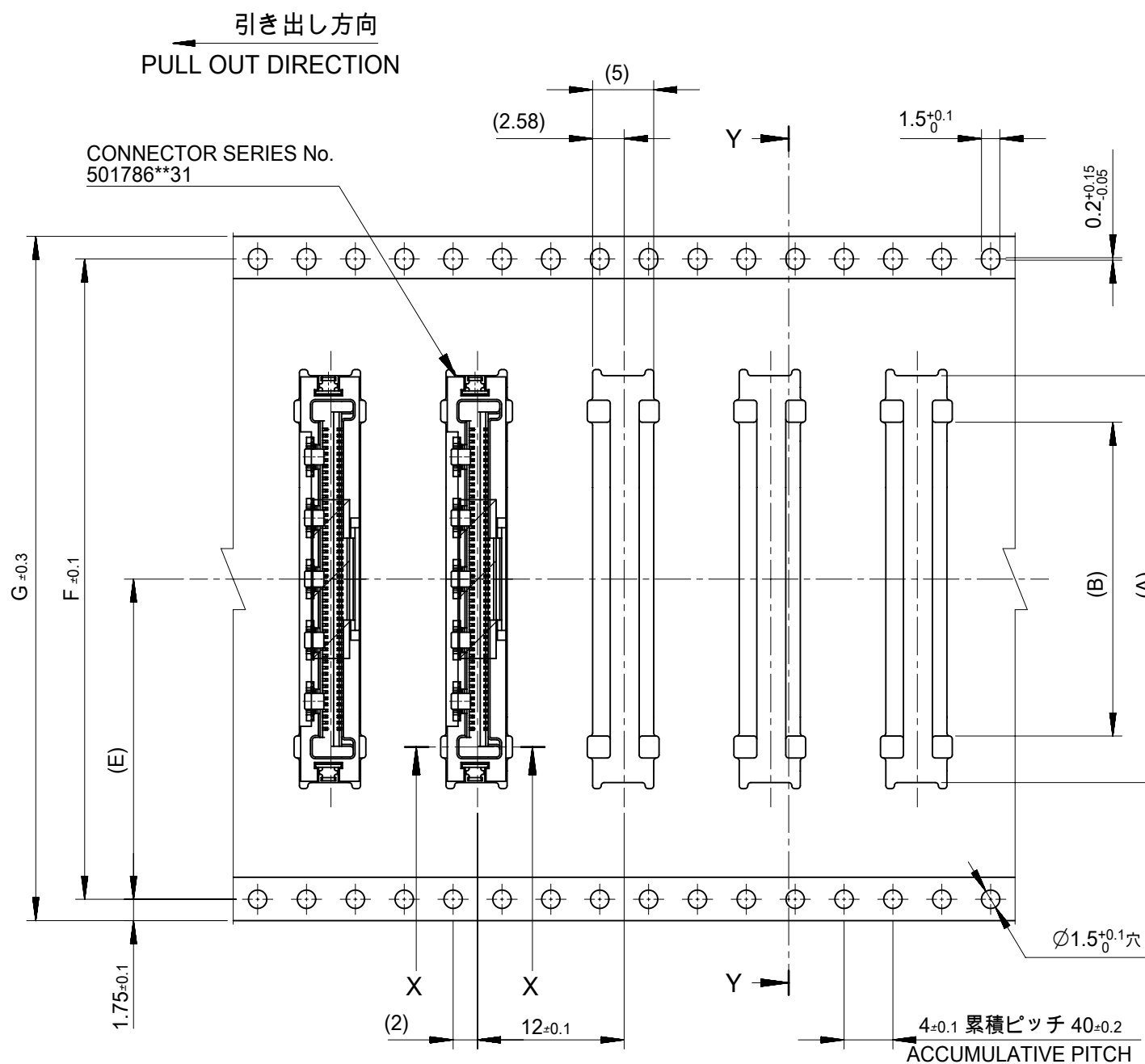

SECT. X-X

THIS DRAWING CONTAINS INFORMATION THAT IS PROPRIETARY TO MOLEX ELECTRONIC TECHNOLOGIES, LLC AND SHOULD NOT BE USED WITHOUT WRITTEN PERMISSION									
DIMENSION UNITS		SCALE		CURRENT REV DESC:					
mm		1:1							
GENERAL TOLERANCES (UNLESS SPECIFIED)				EC NO: 628512				EMBSTP PKG FOR	
ANGULAR TOL ± 3.0°				DRWN: SKITAZAWA 2020/02/04				0.5 FFC TO BOARD ST TYPE	
4 PLACES ± 0.2				CHK'D: HSHIMOYAMA 2020/02/04				PRODUCT CUSTOMER DRAWING	
3 PLACES ± 0.2				APPR: SHOSHIKAWA 2020/02/04				DOCUMENT NUMBER	
2 PLACES ± 0.25				INITIAL REVISION:				5017860002	
1 PLACE ± 0.3				DRWN: VLM 2016/02/17				DOC TYPE	
0 PLACES ± 0.3				APPR: TKUSUHARA01 2017/04/28				PSD	
DRAFT WHERE APPLICABLE MUST REMAIN WITHIN DIMENSIONS		THIRD ANGLE PROJECTION		DRAWING		SERIES		MATERIAL NUMBER	
				A3-SIZE		501786		CUSTOMER	
						SEE CHART		GENERAL MARKET	
								SHEET NUMBER	
								2 OF 2	

注記 NOTES

1. 使用材料 MATERIAL
 ハウジング：液晶ポリマー(LCP)、ガラス充填、UL94V-0、黒色
 ターミナル：銅合金 (t=0.18)
 補強金具：銅合金 (t=0.25)
 グランド端子：銅合金 (t=0.15)
 HOUSING : LIQUID CRYSTAL POLYMER(LCP), GLASS FILLED, UL94V-0, BLACK
 TERMINAL : COPPER ALLOY (t=0.18)
 FITTING NAIL : COPPER ALLOY (t=0.25)
 GROUND TERMINAL : COPPER ALLOY (t=0.15)
2. めっき仕様 PLATING
 ターミナル
 コンタクト：金めっき(0.1μm以上) 下地：ニッケルめっき(1.0μm以上)
 ソルダテール：金めっき 下地：ニッケルめっき
 補強金具：錫めっき(1.0μm以上) 下地：ニッケルめっき
 グランド端子：錫めっき(1.0μm以上) 下地：ニッケルめっき
 TERMINAL
 CONTACT AREA : GOLD PLATING(0.1μm MAX) UNDERPLATING : NICKEL PLATING(1.0μmMAX)
 SOLDER TAIL AREA : GOLD PLATING UNDERPLATING : NICKEL PLATING
 FITTING NAIL : TIN PLATING(1.0μmMAX) UNDER PLATING : NICKEL PLATING
 GROUND TERMINAL : TIN PLATING(1.0μmMAX) UNDER PLATING : NICKEL PLATING

③ パターン剥離止め用補強金具
 FITTING NAIL FOR PREVENTION OF PEELING OF P.C.B. PATTERN.

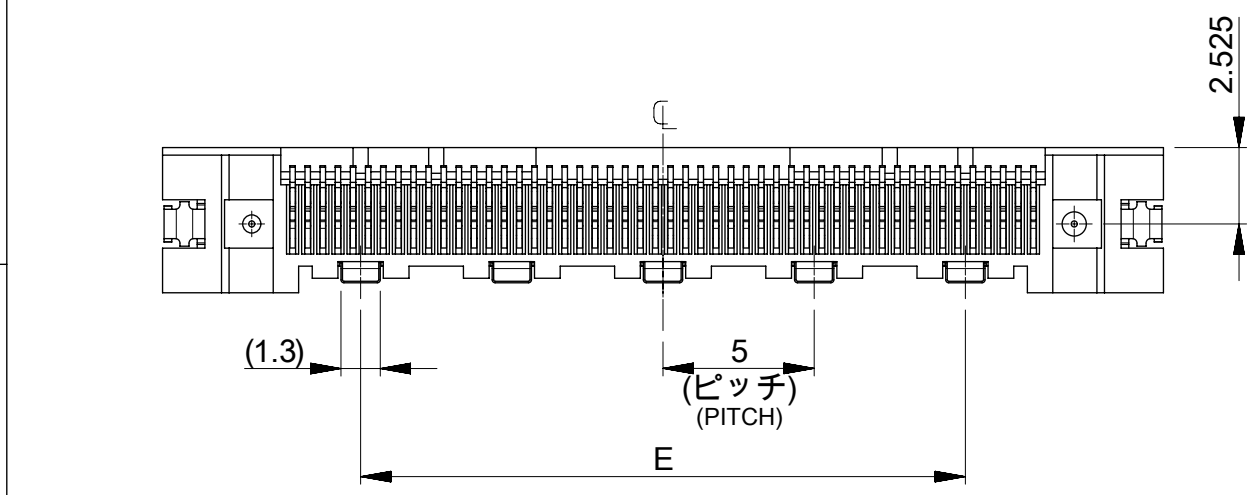
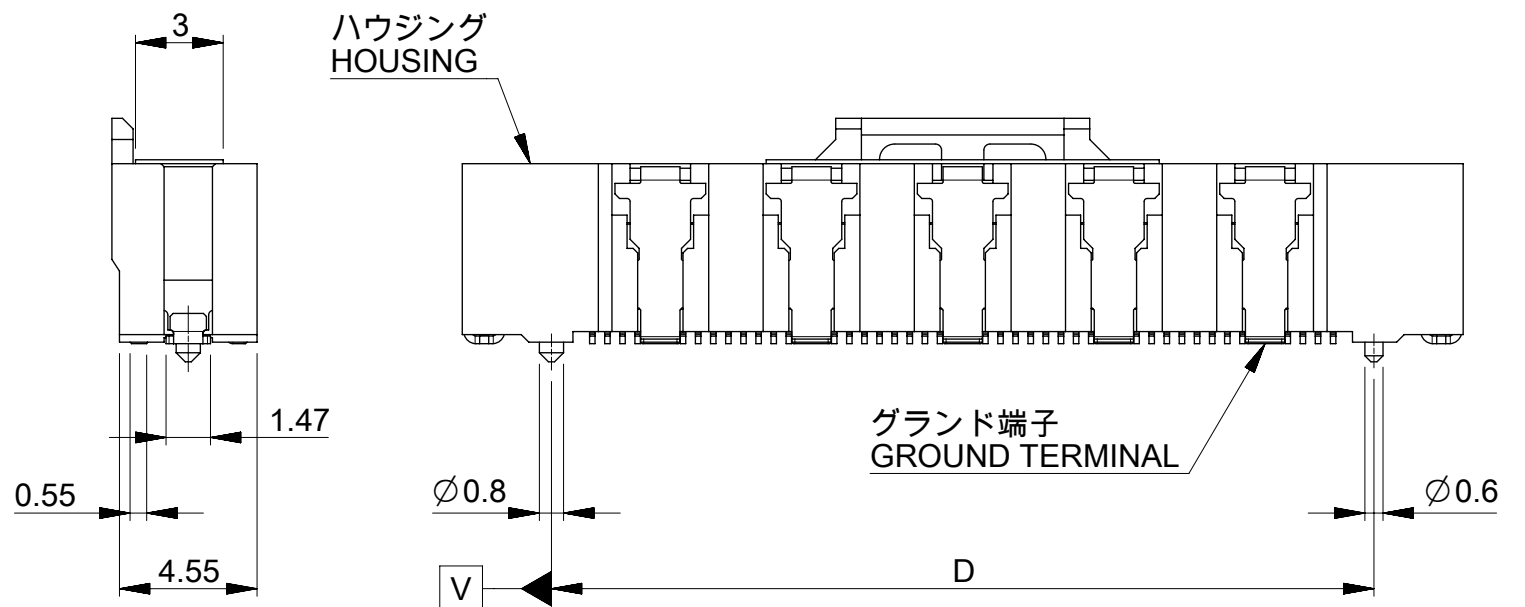
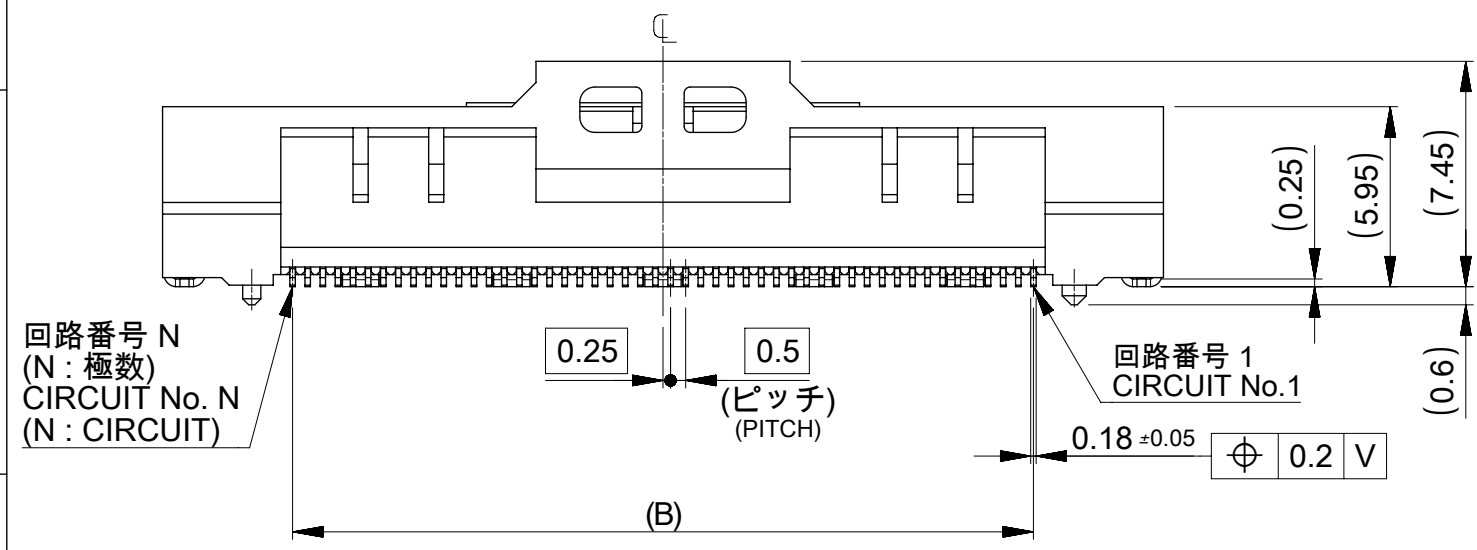
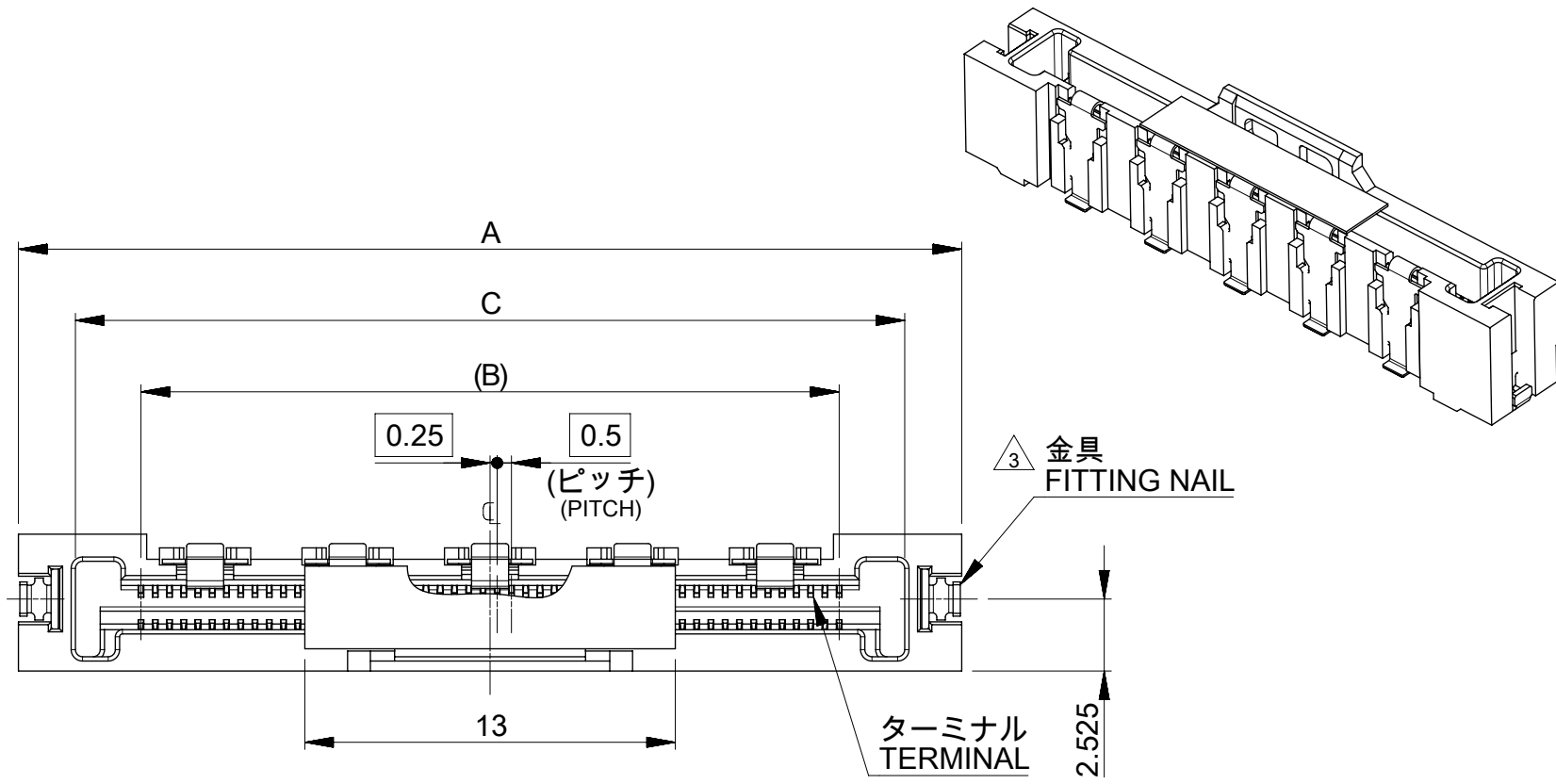

5	20	27.2	29.1	24.5	33.1	5017865091	50
4	15	22.2	24.1	19.5	28.1	5017864091	40
3	10	17.2	19.1	14.5	23.1	5017863091	30
QTY of Ground Terminal	E	D	C	B	A	EMBOSSED PACKAGE	Circuit
						オーダー番号 ORDER No.	

THIS DRAWING CONTAINS INFORMATION THAT IS PROPRIETARY TO MOLEX ELECTRONIC TECHNOLOGIES, LLC AND SHOULD NOT BE USED WITHOUT WRITTEN PERMISSION

DIMENSION UNITS	SCALE	CURRENT REV DESC:		molex			
mm	4:1	EC NO: 628512					
GENERAL TOLERANCES (UNLESS SPECIFIED)		DRWN: SKITAZAWA 2020/02/04		0.5 FFC TO BOARD CONN REC HSG ASSY(ST)			
ANGULAR TOL	± 3.0°	CHK'D: HSHIMOYAMA 2020/02/04		PRODUCT CUSTOMER DRAWING			
4 PLACES	± 0.2	APPR: SHOSHIKAWA 2020/02/04		DOCUMENT NUMBER			
3 PLACES	± 0.2	INITIAL REVISION:		5017861002			
2 PLACES	± 0.25	DRWN: NKURAHATTI 2016/02/26		DOC TYPE			
1 PLACE	± 0.3	APPR: TKUSUHARA01 2017/04/28		PSD			
0 PLACES	± 0.3	THIRD ANGLE PROJECTION		DOC PART			
DRAFT WHERE APPLICABLE MUST REMAIN WITHIN DIMENSIONS		DRAWING		000			
		SERIES		D			
		MATERIAL NUMBER		SEE CHART			
		CUSTOMER		GENERAL MARKET			
		SHEET NUMBER		1 OF 3			

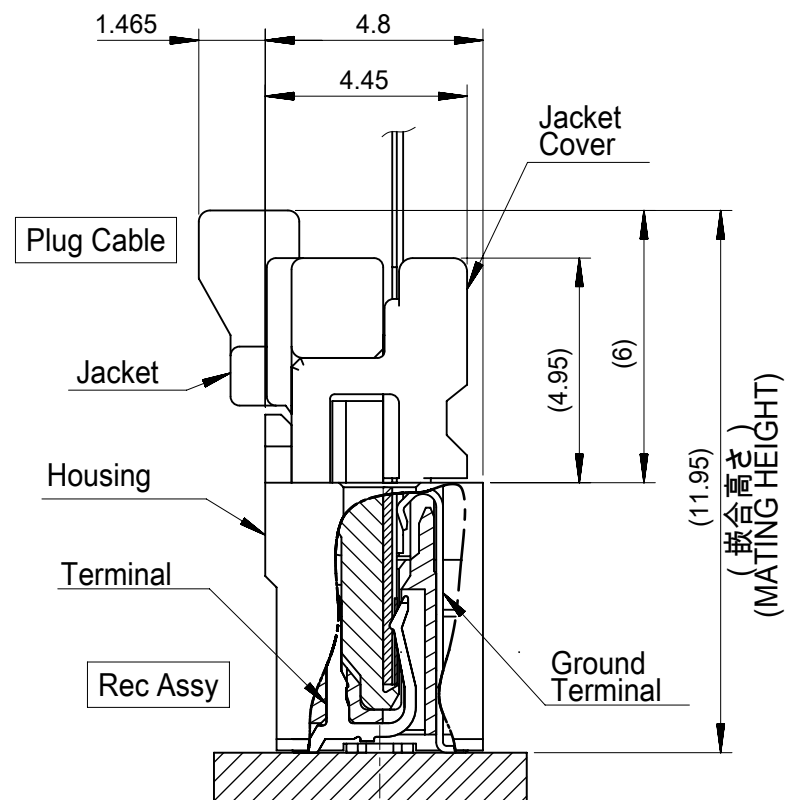

大ラッチジャケット嵌合断面図
 LARGE LATCH JACKET
 MATED CONNECTOR SECTION

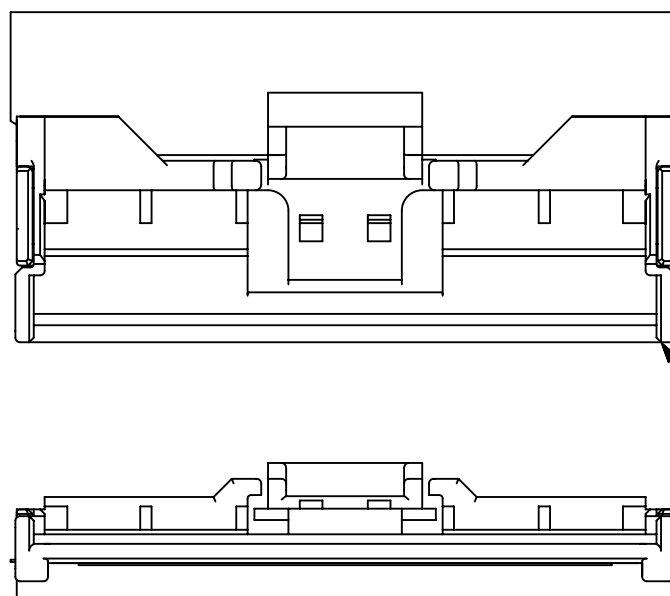

大ラッチジャケット
 LARGE LATCH JACKET

適合ジャケットカバー : 503151**09
 製品詳細寸法はSD-503151-001を参照下さい。
 APPLICABLE JACKET COVER : 503151**09.
 DETAIL DIMENSION IS REFER TO SD-503151-001.

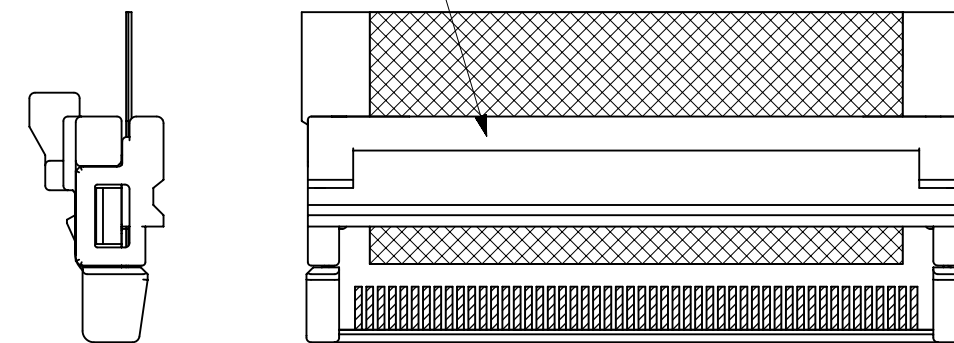

適合大ラッチジャケット : 503150**09
 製品詳細寸法はSD-503150-001を参照下さい。
 APPLICABLE LARGE LATCH JACKET : 503150**09.
 DETAIL DIMENSION IS REFER TO SD-503150-001.

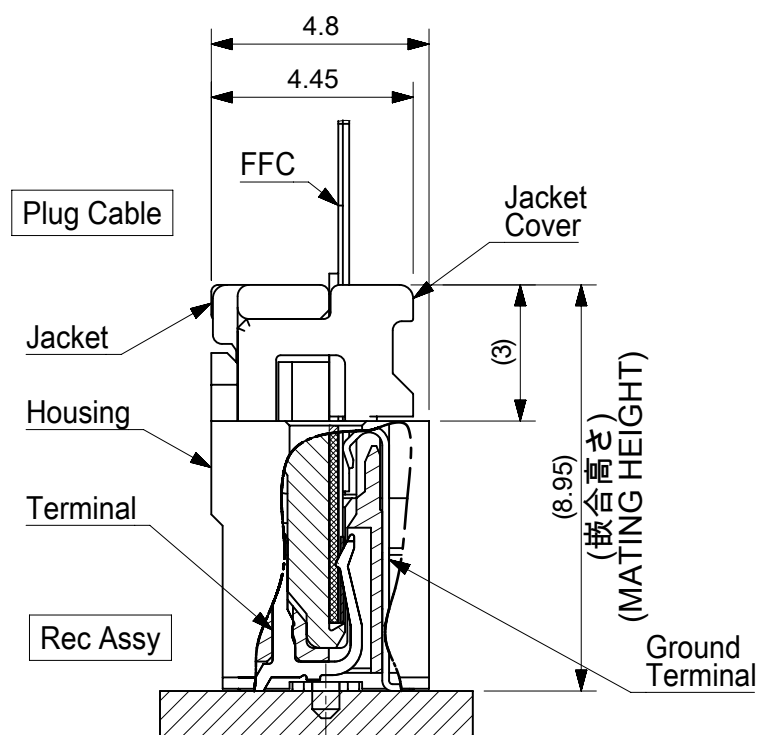

小ラッチジャケット嵌合断面図
 SMALL LATCH JACKET
 MATED CONNECTOR SECTION

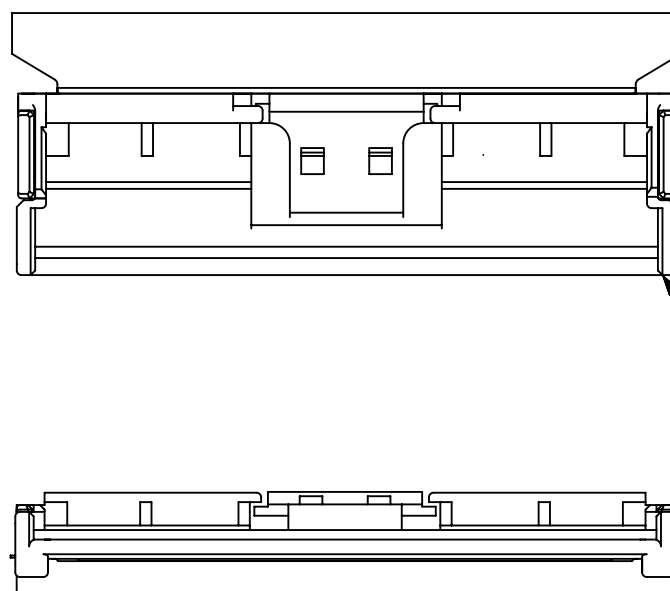

小ラッチジャケット
 SMALL LATCH JACKET

適合ジャケットカバー : 501784**08
 製品詳細寸法はSD-501784-005を参照下さい。
 APPLICABLE JACKET COVER : 501784**08.
 DETAIL DIMENSION IS REFER TO SD-501784-005.

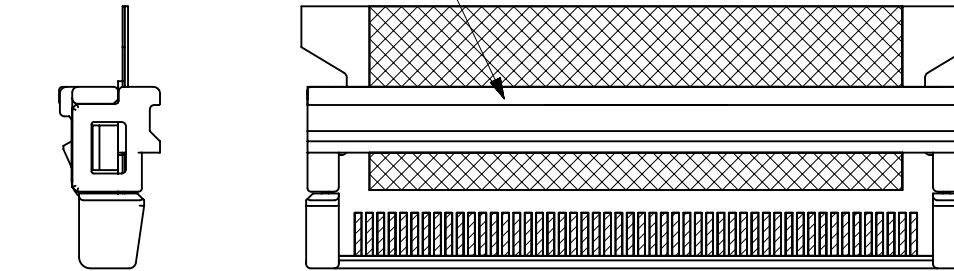

適合小ラッチジャケット : 501783**09
 製品詳細寸法はSD-501783-004を参照下さい。
 APPLICABLE SMALL LATCH JACKET : 501783**09.
 DETAIL DIMENSION IS REFER TO SD-501783-004.

THIS DRAWING CONTAINS INFORMATION THAT IS PROPRIETARY TO MOLEX ELECTRONIC TECHNOLOGIES, LLC AND SHOULD NOT BE USED WITHOUT WRITTEN PERMISSION		CURRENT REV DESC:		molex	
DIMENSION UNITS	SCALE				
mm	1:1			0.5 FFC TO BOARD CONN REC HSG ASSY(ST)	
GENERAL TOLERANCES (UNLESS SPECIFIED)		EC NO: 628512		PRODUCT CUSTOMER DRAWING	
ANGULAR TOL	± 3.0 °	DRWN: SKITAZAWA	2020/02/04	DOCUMENT NUMBER	
4 PLACES	± 0.2	CHK'D: HSHIMOYAMA	2020/02/04	5017861002	
3 PLACES	± 0.2	APPR: SHOSHIKAWA	2020/02/04	DOC TYPE	DOC PART
2 PLACES	± 0.25	INITIAL REVISION:		PSD	000
1 PLACE	± 0.3	DRWN: NKURAHATTI	2016/02/26	REVISION	
0 PLACES	± 0.3	APPR: TKUSUHARA01	2017/04/28	D	
DRAFT WHERE APPLICABLE MUST REMAIN WITHIN DIMENSIONS		THIRD ANGLE PROJECTION	DRAWING	SERIES	MATERIAL NUMBER
			A3-SIZE	501786	CUSTOMER
					GENERAL MARKET
					SHEET NUMBER
					2 OF 3

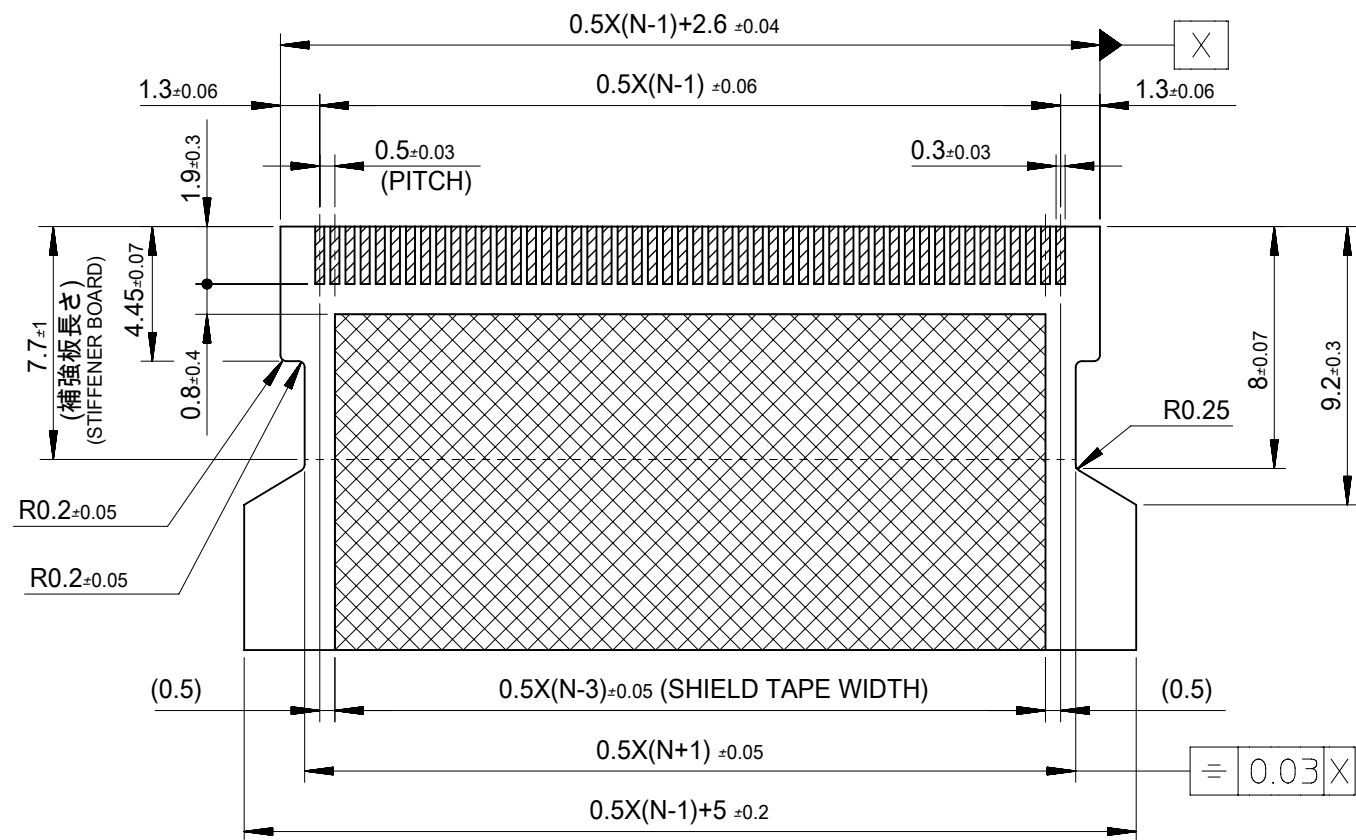

適合FFC推奨寸法
APPLICABLE FFC RECOMENDED DIMENSION

仕上がり厚さ THICKNESS
 コネクタ接点部 : 0.3±0.03
 CONNECTOR CONTACT PORTION : 0.3±0.03
 シールド部 : 0.44±0.05
 SHIELD PORTION : 0.44±0.05

 コネクタ接点部
CONNECTOR CONTACT PORTION
 シールド部
SHIELD PORTION

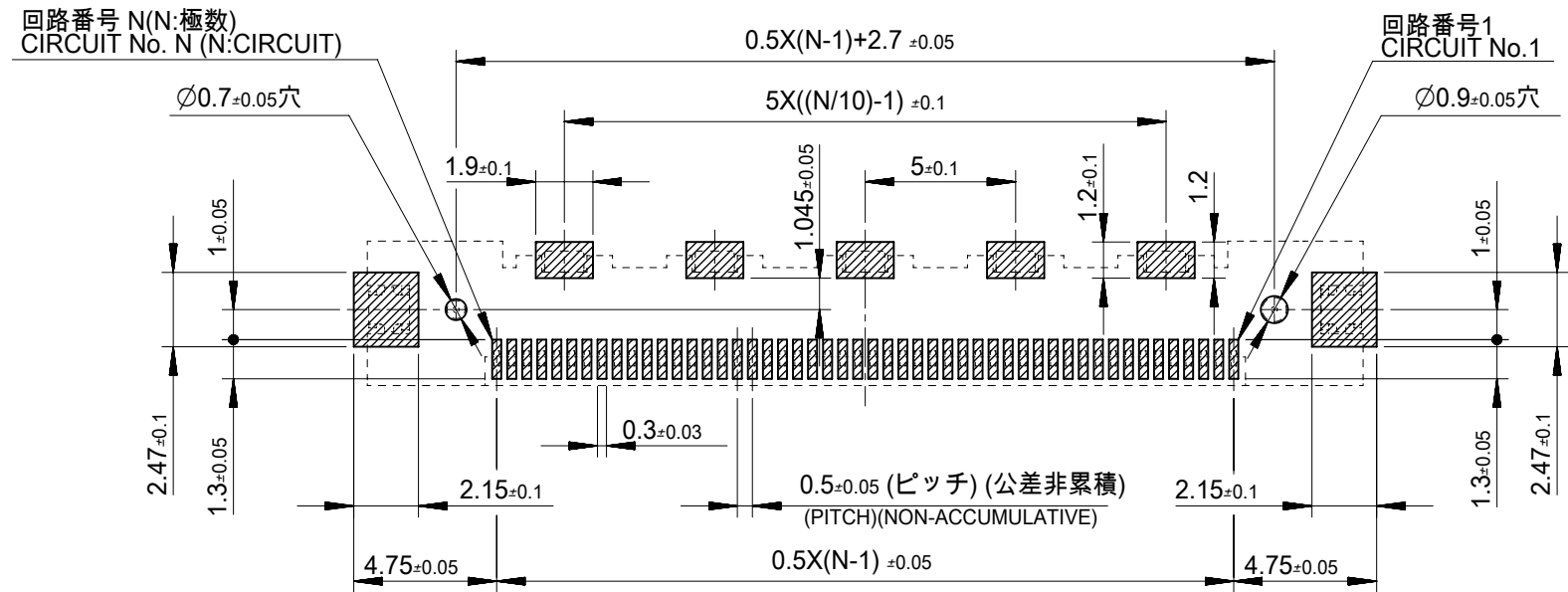

参考基板レイアウト
P.C.BOARD PATTERN DIMENSION(REF.)
(マウント面) (MOUNTING SIDE)

参考マスク厚 : 120μm
 REFERENCE SCREEN THICKNESS : 120μm
 参考マスク開口率 : 100%
 REFERENCE SCREEN OPEN RATIO : 100%

FFCについて ABOUT FFC

打ち抜き方向は導体側から補強板側を推奨します。
 導体部については軟箔銅35μmまたは50μmを推奨します。
 FFCに規定された定格温度がFFC単体前提である場合が御座います。
 コネクタと組み合わせての実使用において、接着層が劣化するなどの信頼性を満足できないケースを回避するため、
 実機での評価/確認をお願いいたします。

RECOMMENDED PUNCHING DIRECTION : FROM CONDUCTOR SIDE TO STIFFENER SIDE

RECOMMENDED CONDUCTOR SPEC : SOFT COPPER FOIL

RECOMMENDED CONDUCTOR THICKNESS : 35 MICROMETER OR 50 MICROMETER

NOTE : WHEN ACTUALLY USING IT WITH CONNECTOR, PLEASE DO THE EVALUATION AND THE CONFIRMATION WITH AN ACTUAL EQUIPMENT TO EVADE THE CASE WHERE RELIABILITY CANNOT BE FILLED (THE ADHESIVE LINE OF FFC IS DETERIORATED ETC.)

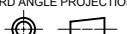
THIS DRAWING CONTAINS INFORMATION THAT IS PROPRIETARY TO MOLEX ELECTRONIC TECHNOLOGIES, LLC AND SHOULD NOT BE USED WITHOUT WRITTEN PERMISSION									
DIMENSION UNITS		SCALE		CURRENT REV DESC:				molex	
mm		1:1							
GENERAL TOLERANCES (UNLESS SPECIFIED)				EC NO: 628512				0.5 FFC TO BOARD CONN REC HSG ASSY(ST)	
ANGULAR TOL ± 3.0°				DRWN: SKITAZAWA 2020/02/04				PRODUCT CUSTOMER DRAWING	
4 PLACES ± 0.2				CHK'D: HSHIMOYAMA 2020/02/04					
3 PLACES ± 0.2				APPR: SHOSHIKAWA 2020/02/04				DOCUMENT NUMBER	
2 PLACES ± 0.25				INITIAL REVISION:					
1 PLACE ± 0.3				DRWN: NKURAHATTI 2016/02/26				5017861002	
0 PLACES ± 0.3				APPR: TKUSUHARA01 2017/04/28					
DRAFT WHERE APPLICABLE MUST REMAIN WITHIN DIMENSIONS		THIRD ANGLE PROJECTION		DRAWING		SERIES		SHEET NUMBER	
				A3-SIZE		501786		3 OF 3	
CUSTOMER		MATERIAL NUMBER		GENERAL MARKET		PSD		000 D	