

Customer Information Sheet

DRAWING No.: H2101B01 - H2103B01

IF IN DOUBT - ASK

©

NOT TO SCALE

THIRD ANGLE PROJECTION

ALL DIMENSIONS IN mm

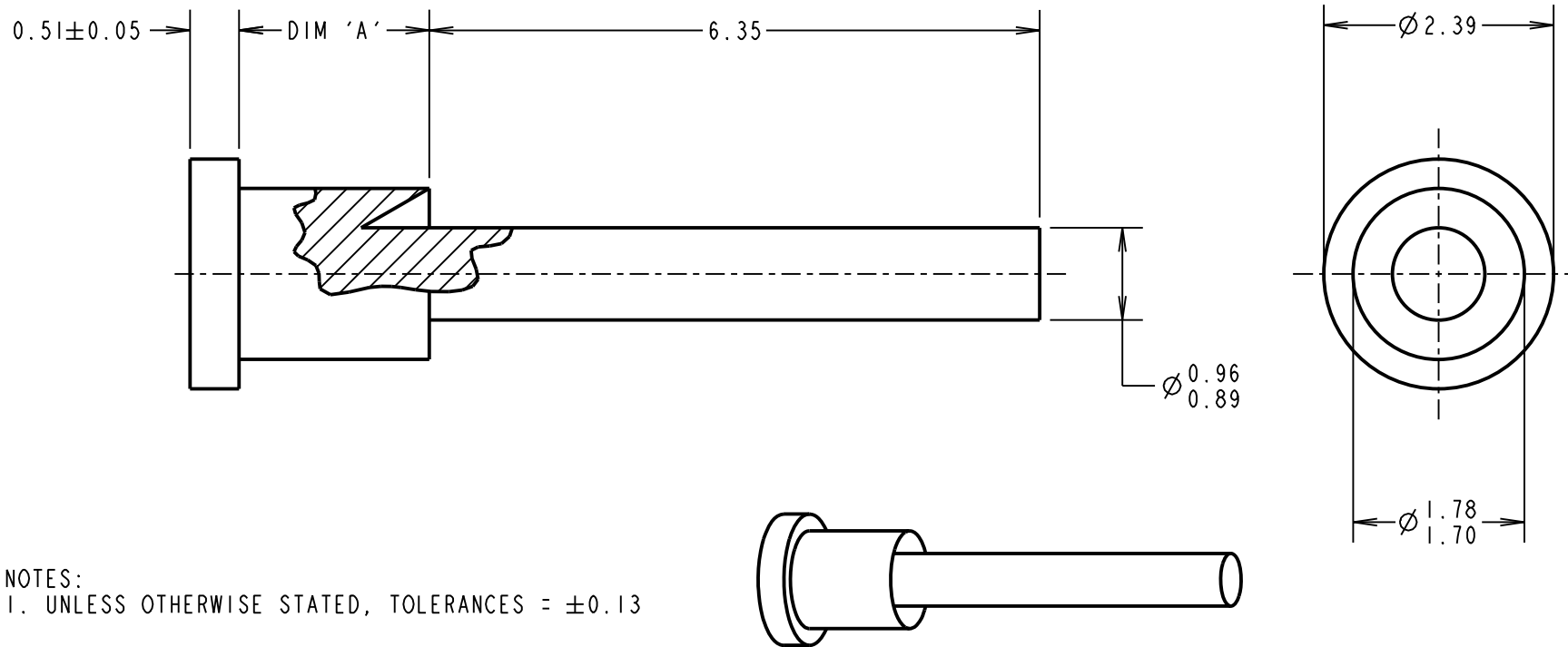

NOTES:
1. UNLESS OTHERWISE STATED, TOLERANCES = ± 0.13

MGP	15	29.07.21	30714
NAME	ISS.	DATE	CN/CO
APPROVED: MGP			
CHECKED: RA			
DRAWN: JM BROOKES			
CUSTOMER REF.:			
ASSEMBLY DRG:			

PART No.	DIM 'A'	HOLE SIZE	BOARD THICKNESS	PUNCH AND DIE TOOL
H2101B01	1.98 / 2.10	$\varnothing 1.79/1.87\text{mm}$	1.60mm	Z2101B00
H2102B01	2.79 / 2.91	$\varnothing 1.79/1.87\text{mm}$	2.40mm	Z2102B00
H2103B01	3.56 / 3.68	$\varnothing 1.79/1.87\text{mm}$	3.20mm	Z2103B00

HARWIN

www.harwin.com
technical@harwin.com

THIS DRAWING AND ANY INFORMATION OR DESCRIPTIVE MATTER SET OUT HEREON ARE CONFIDENTIAL AND COPYRIGHT PROPERTY OF THE HARWIN GROUP AND MUST NOT BE DISCLOSED, LOANED, COPIED OR USED FOR MANUFACTURING, TENDERING OR FOR ANY OTHER PURPOSE WITHOUT THEIR WRITTEN PERMISSION.

~~TOLERANCES~~
~~X = $\pm 1\text{mm}$~~
~~X.X = $\pm 0.50\text{mm}$~~
~~X.XX = $\pm 0.20\text{mm}$~~
~~X.XXX = $\pm 0.10\text{mm}$~~
 ANGLES = $\pm 5^\circ$
 UNLESS STATED

MATERIAL:
ANNEALED BRASS
CW614N M TO BS EN 12164
FINISH: 100% TIN OVER NICKEL
S/AREA: mm²

TITLE:
TERMINAL
DRAWING NUMBER:
H2101B01 - H2103B01
SHT
2 OF 2