

UNCONTROLLED DOCUMENT

PART NUMBER		REV.
OED-EL305F4C50-HT		A
REV.	E.C.N. NUMBER AND REVISION COMMENTS	DATE
A	E.C.N. #11148.	4.30.07

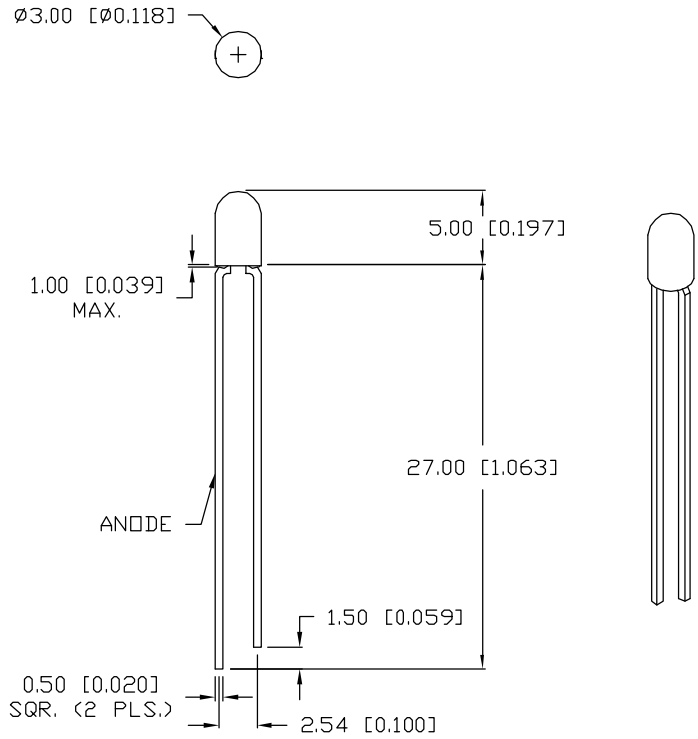

ELECTRO-OPTICAL CHARACTERISTICS $T_A=25^\circ\text{C}$ $I_f=20\text{mA}$

PARAMETER	MIN	TYP	MAX	UNITS	TEST COND
PEAK WAVELENGTH		940		nm	
SPECTRAL BANDWIDTH		50		nm	
FORWARD VOLTAGE		1.2	1.6	V_f	
REVERSE VOLTAGE	5.0			V_r	$I_r=10\mu\text{A}$
RADIANT INTENSITY	7	15		mW/SR	$I_f=20\text{mA}$
HALF ANGLE		± 25		degrees	

EPOXY LENS FINISH: WATER CLEAR

LIMITS OF SAFE OPERATION AT 25°C

PARAMETER	MAX	UNITS
PEAK FORWARD CURRENT*	1.2	A
STEADY CURRENT	50	mA
POWER DISSIPATION	100	mW
DERATE FROM 25°C	-1.2	mW/ $^\circ\text{C}$
OPERATING TEMP.	-40 TO +85	$^\circ\text{C}$
STORAGE TEMP.	-40 TO +85	$^\circ\text{C}$
SOLDERING TEMP.	+260	$^\circ\text{C}$
2.0mm FROM BODY		3 SEC. MAX

* $t_p < 100\mu\text{s}$, $t_p/T = 0.01$

NOTES:

- HIGH TEMP EPOXY.



UNCONTROLLED DOCUMENT

*UNLESS OTHERWISE SPECIFIED TOLERANCES PER DECIMAL PRECISION ARE: X=±1 (±0.039), X.X=±0.5 (±0.020), X.XX=±0.25 (±0.010), X.XXX=±0.127 (±0.005). LEAD SIZE=±0.05 (±0.002), LEAD LENGTH=±0.75 (±0.030). MIN=+DECIMAL PRECISION MAX.=+0.00 -DECIMAL PRECISION

REV.	PART NUMBER
A	OED-EL305F4C50-HT
T-3mm (T-1) 940nm INFRARED EMITTER, WATER CLEAR LENS, HIGH TEMP EPOXY.	

CONFIDENTIAL INFORMATION
 THE INFORMATION CONTAINED IN THIS DOCUMENT IS THE PROPERTY OF LUMEX INC. EXCEPT AS SPECIFICALLY AUTHORIZED IN WRITING BY LUMEX INC., THE HOLDER OF THIS DOCUMENT SHALL KEEP ALL INFORMATION CONTAINED HEREIN CONFIDENTIAL AND SHALL PROTECT SAME IN WHOLE OR IN PART FROM DISCLOSURE AND DISSEMINATION TO ALL THIRD PARTIES.

RELIABILITY NOTE
 OUR MANY YEARS OF EXPERIENCE DATA ACCUMULATION INDICATE THAT SOLDER HEAT IS A MAJOR CAUSE OF EARLY AND FUTURE FAILURE. PLEASE PAY ATTENTION TO YOUR SOLDERING PROCESS.

		290 E. HELEN ROAD PALATINE, IL 60067-6976 PHONE: +1.847.359.2790 US WEB: www.lumex.com TW WEB: www.lumex.com.tw	
DRAWN BY:	CHECKED BY:	APPROVED BY:	DATE: 3.6.06
JC			PAGE: 1 OF 1
			SCALE: N/A