

SERIES 3000 CUSTOM PACKAGED THERMOSTATS

Typical Applications:

Aircraft Bleed Air
Duct Sensing

Hydraulic Oil
Temperature Control

Liquid Bath Control

Heater Control



The Series 3000 incorporates an Elmwood Sensors' thermostat assembled in a custom package for use in a variety of applications that require flexibility in mounting and terminal configurations.

A typical configuration includes:
Series 3100 Hermetic Internal Thermostat
Terminal Selection
Housing Selection
Customized Part Number

The opposite page shows a variety of connectors, leads, terminals and shells currently available for hermetic thermostats. See **Part III, Section B for Non-Hermetic Configurations**, or call **Elmwood Sensors for configurations not shown here**.

To insure that a safe combination of thermostat and application is achieved, the purchaser must determine product suitability for their individual requirements.

Key Features:

- Customized Probe Length (up to 6" or 152mm)
- Connector Options
- Internal and External Design Options

For a customized part number, replace the X which appears at the end of the Housing number with your terminal selection.

Example: Part Number 3000-531

SERIES 3000 CUSTOM PACKAGED THERMOSTATS

Terminations

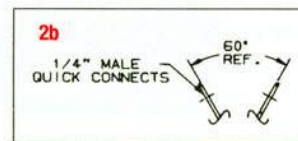
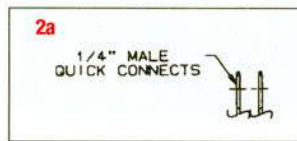
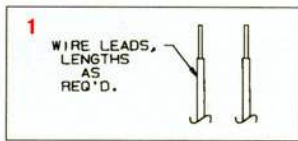
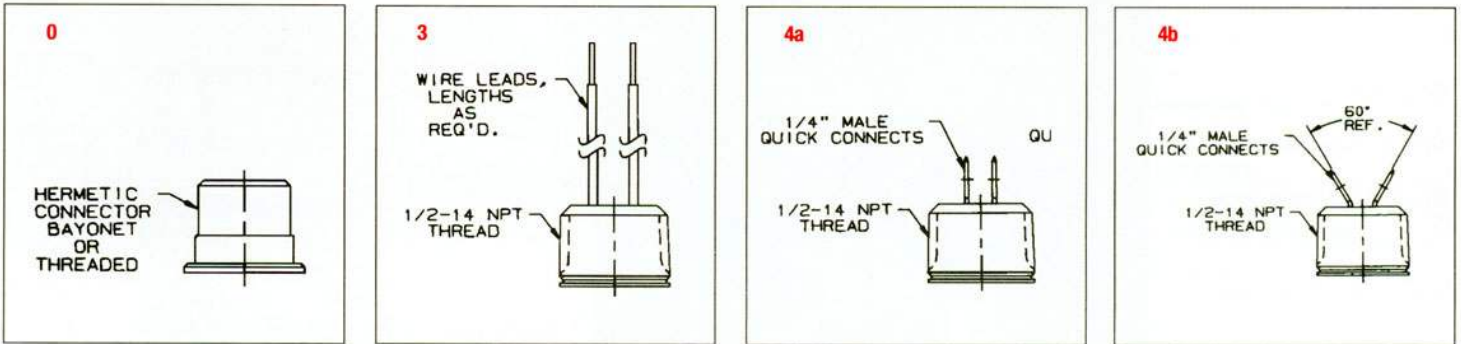

Housings

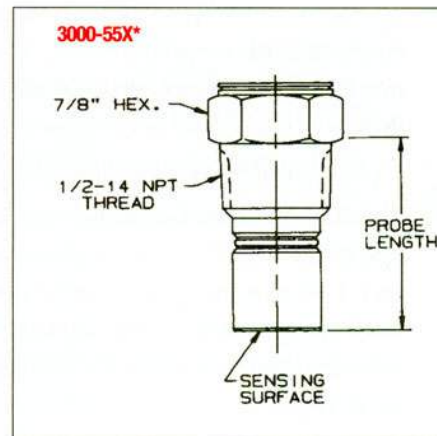
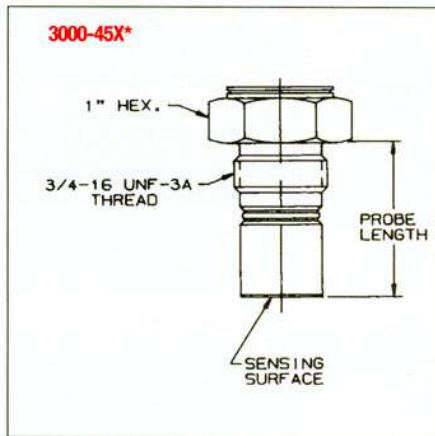

Terminations

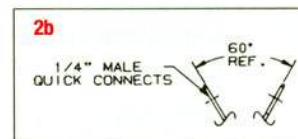
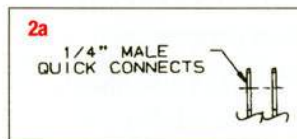
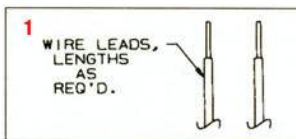

Housings

