

LOC		DIST		REVISIONS			
P	LTR	DESCRIPTION	DATE	DNW	APVD		
P2		REV PER ECO-20-004668	02JUN2020	ML	SZ		

- 1 MATERIAL: HOUSING : POLYESTER, COLOR, GRAY. UL 94V-0. CONTACT: HIGH CONDUCTIVITY COPPER ALLOY.
- 2 FINISH: IN ACCORDANCE WITH PRODUCT SPECIFICATION 108-1651, GOLD PLATING OR EQUIVALENT PLATING ON PRODUCT CONTACT MATING AREA, AND MATTE TIN PLATING ON COMPLIANT PIN AREA, ALL OVER MATTE NICKEL UNDERPLATED. DETAIL PLEASE REFER TO PRODUCT SPECIFICATION 108-1651.
- 3 TOLERANCE TO BE ± 0.28 AFTER CONNECTOR IS APPLIED TO PC BOARD.
- 4 DATE CODE THIS APPROXIMATE AREA, OPPOSITE SIDE.
- 5 REFERENCE APPLICATION SPEC 114-1103 FOR RECOMMENDED PLATED THRU HOLE DIAMETER AND PLATING THICKNESS.
- 6 TOLERANCE TO BE $+0.5/-0.1$ BEFORE CONNECTOR IS APPLIED TO PC BOARD.
- 7 CURRENT RATING 10A/CONTACT PER PRODUCT SPEC 108-1651.

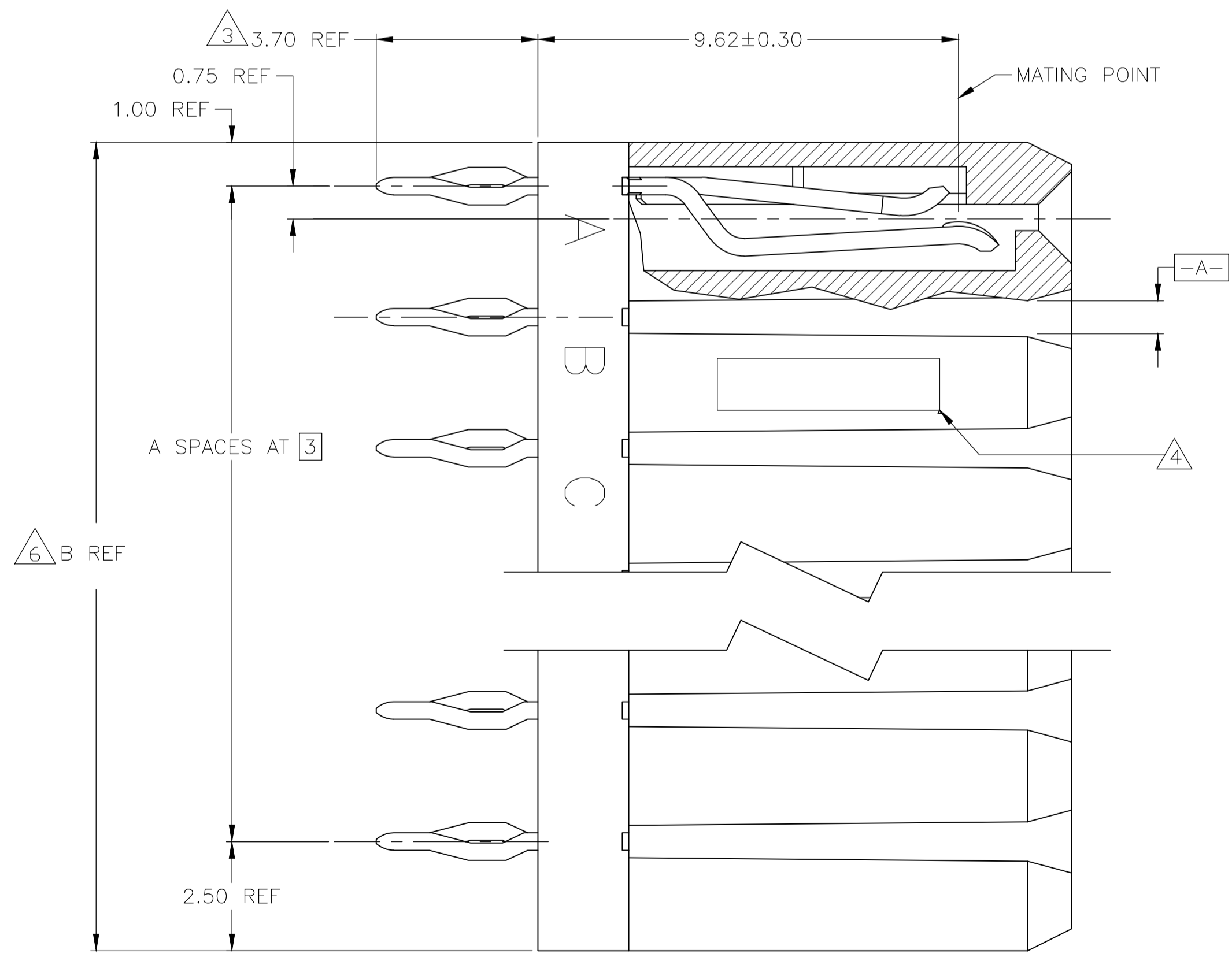
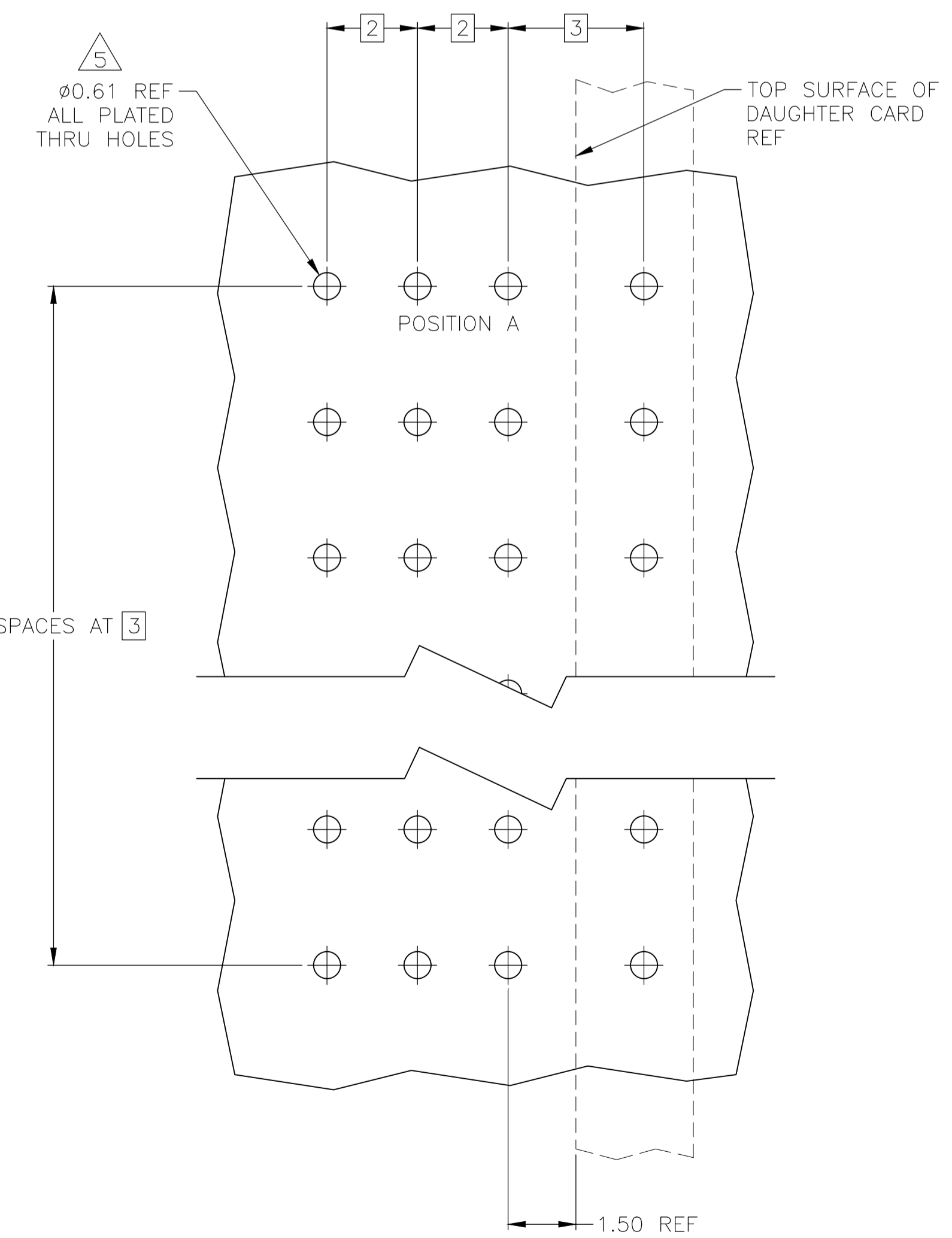
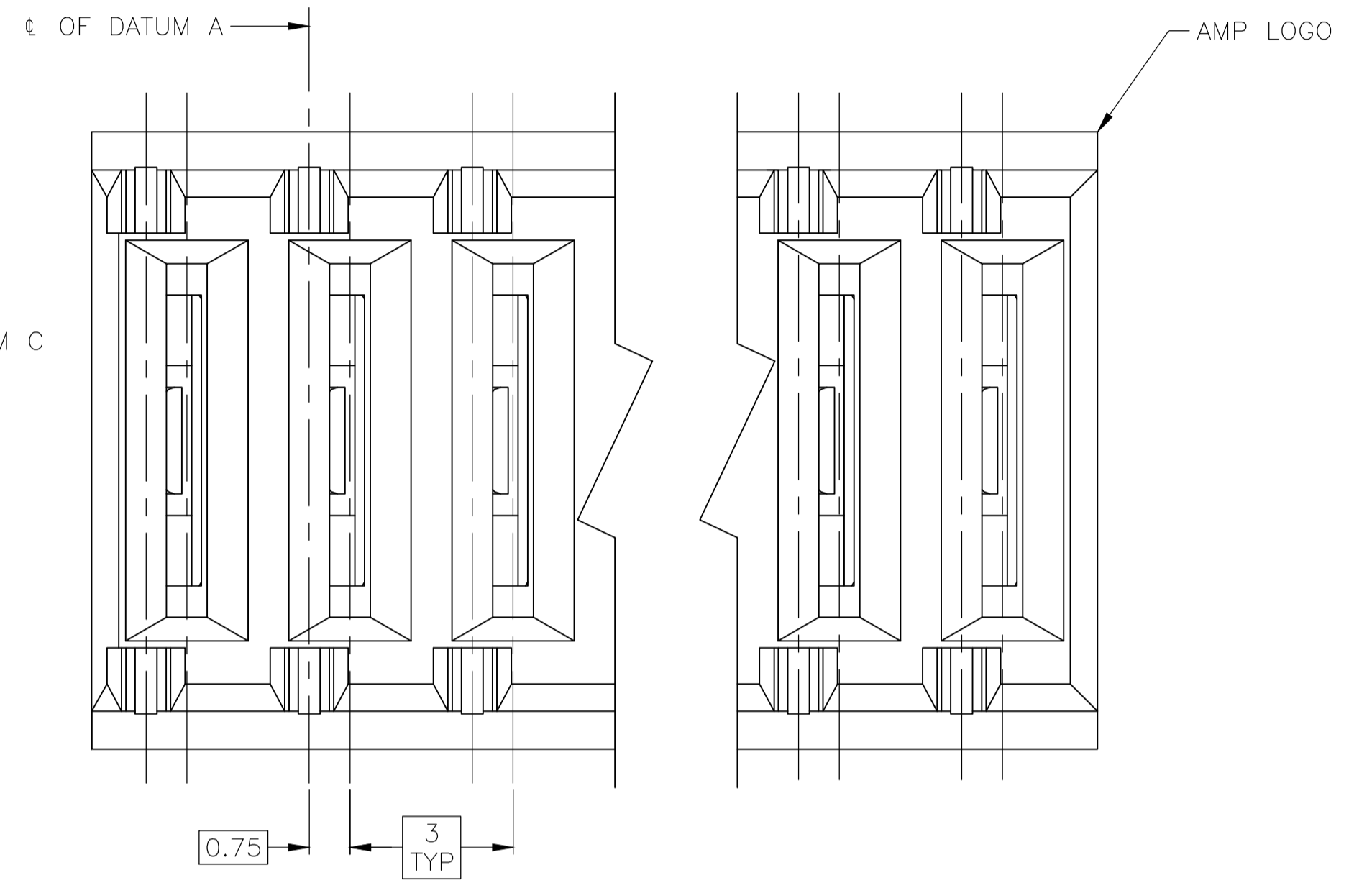
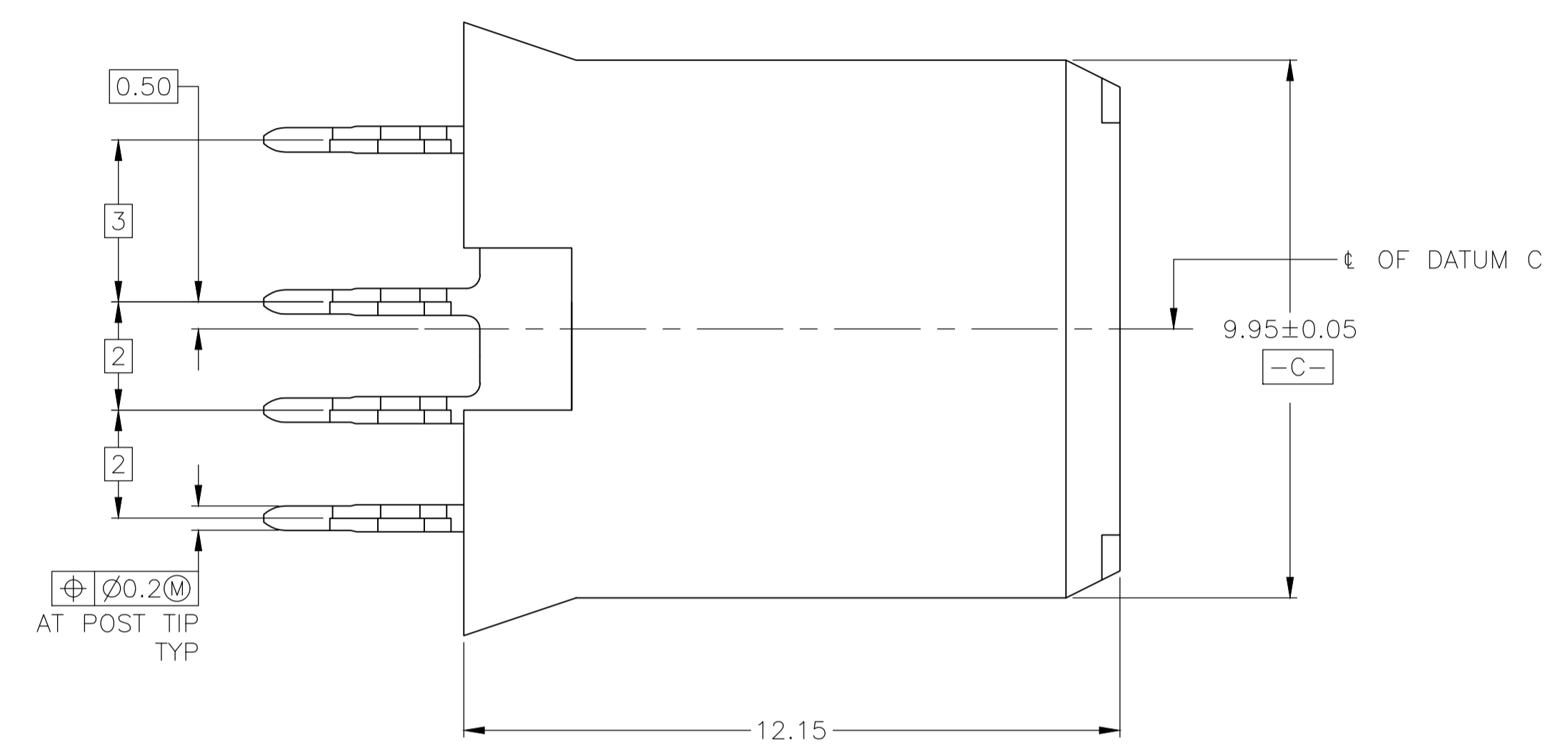
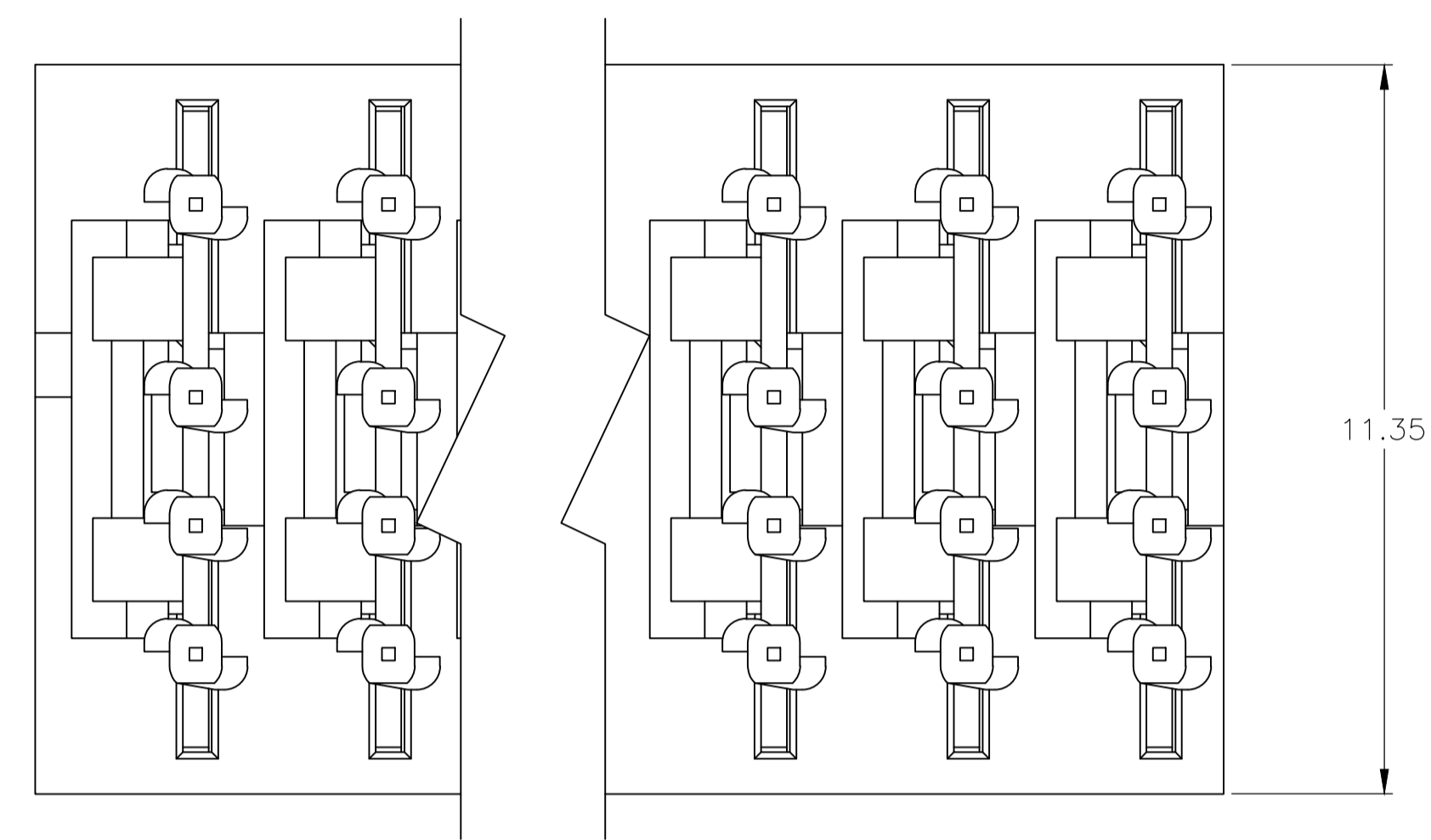

DELETED

POSITION	B REF	A	PART NUMBER
12	36.5	11	5223995-9
11	33.5	10	5223995-8
10	30.5	9	5223995-7
9	27.5	8	5223995-6
8	24.5	7	5223995-5
7	21.5	6	5223995-4
6	18.5	5	5223995-3
5	15.5	4	5223995-2
4	12.5	3	5223995-1

THIS DRAWING IS A CONTROLLED DOCUMENT.

DIMENSIONS:	TOLERANCES UNLESS OTHERWISE SPECIFIED:	DIN	B. CARBO	14DEC04
mm		CHK	R. PATTERSON	14DEC04
		APVD	R. PATTERSON	14DEC04
		NAME		
		PRODUCT SPEC	108-1651	
		APPLICATION SPEC	114-1103	
MATERIAL	FINISH	WEIGHT		
		SIZE	A1	
		CAGE CODE	00779	
		DRAWING NO	5223995	
		RESTRICTED TO		
		CUSTOMER DRAWING		

SCALE 10:1 SHEET 1 OF 1 REV P2

RECOMMENDED PCB HOLE LAYOUT