

Atmel AT18F-DK3 Configurator Development Kit

User Guide





Table of Contents

Section 1

Introduction.....	1-1
1.1 Kit Content	1-1
1.2 Kit Features.....	1-1
1.2.1 The ATF15xx-DK3 with ATF15xxDK3-SAX20.....	1-1
1.2.2 JTAG ISP Download Cable	1-2
1.2.3 JTAG Configurator Programming System (JCPS) Software	1-2
1.3 Supported Devices.....	1-2
1.4 System Requirements.....	1-2
1.5 Ordering Information	1-2
1.6 JCPS References	1-3
1.7 Technical Support.....	1-3

Section 2

Hardware Description.....	2-1
2.1 The ATF15xx-DK3 Base Board	2-1
2.1.1 7-segment Displays with Selectable Jumpers	2-2
2.1.2 LEDs with Selectable Jumpers	2-3
2.1.3 Push-button Switches with Selectable Jumpers for I/O Pins.....	2-4
2.1.4 Push-button Switches with Selectable Jumpers for GCLR and OE1 Pins.....	2-4
2.1.5 2 MHz Oscillator and Clock Selection Jumper.....	2-5
2.1.6 VCCIO and VCCINT Voltage Selection Jumpers and LEDs	2-5
2.1.7 ICCIO and ICCINT Jumpers.....	2-6
2.1.8 Voltage Regulators	2-6
2.1.9 Power Supply Switch and Power LED.....	2-6
2.1.10 Power Supply Jack and Power Supply Header	2-6
2.1.11 JTAG ISP Connector and TDO Selection Jumper.....	2-6
2.2 Socket Adapter Board.....	2-10
2.3 Atmel CPLD ISP Download Cable	2-10

Section 3

Schematic Diagrams	3-1
--------------------------	-----



Section 1

Introduction

The Atmel® AT18F-DK3 Configurator Development Kit is an In-System Programming (ISP) for the AT18F Series of FPGA configuration memories (Configurators). This kit provides designers an easy way to develop, prototype and evaluate new designs using the Atmel AT18F devices. The AT18F Series JTAG ISP Configurator includes devices in four different densities – AT18F010-30XU (1M), AT18F002-30XU (2M), AT18F040-30XU (4M), and AT18F080-30XU (7M). Since all of the devices in the AT18F family are available in only one Green (Halide/Pb-free and RoHS Compliant) 20-lead TSSOP package type, only one socket adapter board (ATF15xxDK3-SAX20) is needed to program the different AT18F devices using the ATF15xx-DK3 Base Board and the Atmel JTAG ISP MV Rev 6.0 Cable (ATDH1151VPC).

1.1 Kit Content

- ATF15xx-DK3 Development Base Board
- 20-lead TSSOP Socket Adapter Board (ATF15xxDK3-SAX20)
- An optional ISP Header Converter
- One AT18F010-30XU and One ATF18F002-30XU Configurator Samples
- A Quick Start Guide
- An AT18F-DK3 Flyer

Note: JCPS Tutorial can be found from the Help menu of the software after installation.

1.2 Kit Features

1.2.1 The ATF15xx-DK3 with ATF15xxDK3-SAX20

- 10-lead JTAG-ISP Port
- Regulated Power Supply Circuits for 9V DC Power Source
- I/O Voltage Supply (VCCIO)⁽¹⁾
- Core Voltage Supply (VCCINT)⁽¹⁾
- 20-lead TSSOP Socket Adapter Board (ATF15xxDK3-SAX20)
- User I/O Pin Headers for All User I/O Pins of the ATF18 Series Configurators
- 2 MHz Crystal Oscillator⁽²⁾
- Four 7-segment LED Displays⁽²⁾
- Eight Individual LEDs⁽²⁾
- Eight Push-button Switches⁽²⁾
- Global Clear and Output Enable Push-button Switches⁽²⁾
- Current Measurement Jumpers

- Notes:**
1. Both VCCIO and VCCINT must be set to 3.3V while programming the AT18F Series devices. When changing the VCCIO or VCCINT jumper position, the power of the ATF15xx-DK3 must be turned OFF.
 2. These features are not intended to be used for the AT18F Series devices on this board. They are intended to be used for the Atmel ATF15xx CPLDs when a different CPLD Socket Adapter Board is used with the ATF15xx-DK3 Base Board.

1.2.2 JTAG ISP Download Cable

- JTAG ISP Download Cable (Atmel JTAG ISP MV Cable V6.0) for PC Parallel Printer (LPT) Port

1.2.3 JTAG Configurator Programming System (JCPS) Software

- Atmel JCPS software can be downloaded from Atmel web site at:
 - http://www.atmel.com/dyn/products/tools_card.asp?tool_id=4278

1.3 Supported Devices

The Atmel AT18F-DK3 Programming Kit supports the following device types.

- AT18F010-30XU
- AT18F002-30XU
- AT18F040-30XU
- AT18F080-30XU

1.4 System Requirements

The minimum hardware and software requirements to program an AT18F Series Configurators on the AT18F-DK3 Programming Kit through the Atmel JTAG Configurator Programming System (JCPS) Software are:

- Pentium® or Pentium Compatible Microprocessor-based Computer
- Windows XP®, Windows 98, Windows NT® 4.0, or Windows® 2000
- 64 Mbytes of RAM
- 200 Mbytes of Free Hard Disk Space
- Windows Supported Mouse
- Available Parallel Printer (LPT) Port
- 9V DC Power Supply with 500 mA of Supply Current
- SVGA Monitor (800 x 600 Resolution)

1.5 Ordering Information

Part Number	Description
ATF18F-DK3	Atmel AT18F Series Configurator Programming Kit

1.6 JCPS References

- **Help Files** – from the JCPS software main window, click on HELP and then select HELP FILE.
- **Tutorials** – from the JCPS software main window, click on HELP, and then select JCPS TUTORIAL.

1.7 Technical Support

For technical support on any Atmel Configurator-related issue, please contact Atmel Configurator Applications Group at:

On-line Support Request Form: <http://www.atmel.com/dyn/products/support.asp>

FAQs: <http://www.atmel.com/dyn/products/faq.asp?Faq=y>

Product Web Site: <http://www.atmel.com/products/config/default.asp>

2.1 The ATF15xx-DK3 Base Board

The ATF15xx-DK3 Base Board and the Socket Adapter Board are shown in [Figure 2-1](#). They contain simple features such as I/O headers that allow designers to easily use it when developing or evaluating the ATF18 Series Configurator designs.

Figure 2-1. The ATF15xx-DK3 Base Board and the ATF15xxDK3-SAX20 Socket Adapter Board

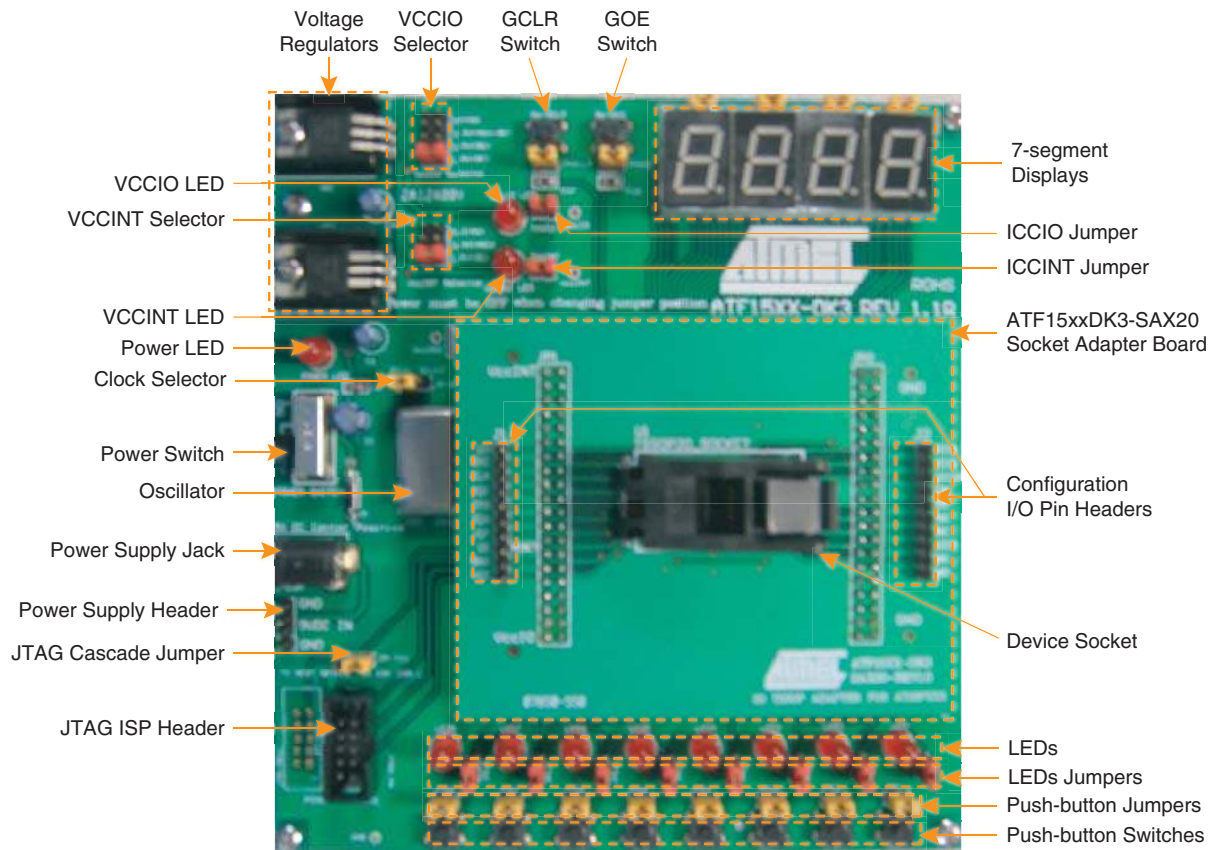

2.1.2 LEDs with Selectable Jumpers

The LEDs with selectable jumpers are available on the ATF15xx-DK3 Base Board of the AT18F-DK3 kit. However, these components were designed for other Atmel adapter boards such as the ATF15xx Series CPLDs and they are not intended to be used with ATF15xxDK3-SAX20 socket adapter for AT18F Series Configurators. Therefore, there is no detailed description about these components in this user guide, if you need additional information, see the ATF15xx-DK3 Kit user guide.

Figure 2-3. Circuit Diagram of the LEDs and Jumpers

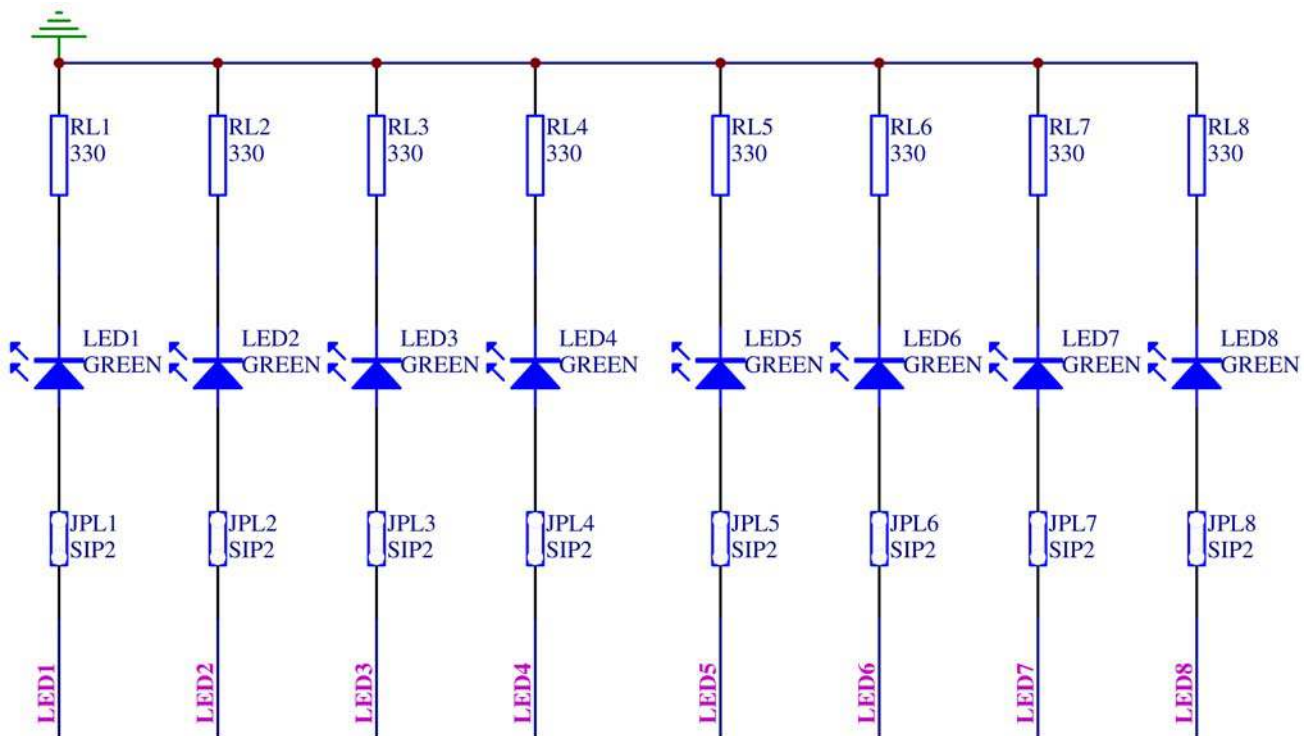

2.1.3 Push-button Switches with Selectable Jumpers for I/O Pins

Eight push-button switches with selectable jumpers are shown on the ATF15xx-DK3 Base Board of the AT18F-DK3 kit. However, these components were designed for other Atmel adapter boards such as the ATF15xx Series CPLDs and they are not intended to be used with ATF15xxDK3-SAX20 socket adapter for AT18F Series Configurators. Therefore, there is no detailed description about these components in this user guide, if you need additional information, see the ATF15xx-DK3 Kit user guide.

Figure 2-4. Circuit Diagram of the Push-button Switches and Jumpers for the I/O Pins

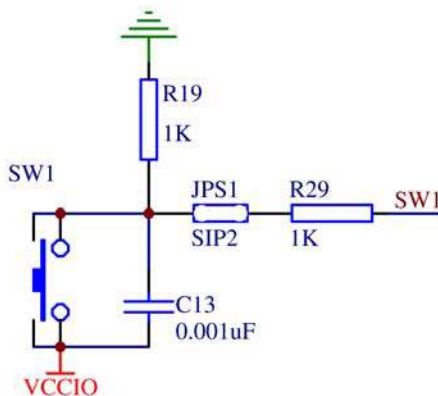

2.1.4 Push-button Switches with Selectable Jumpers for GCLR and OE1 Pins

Two push-button switches for the Global Clear (GCLR) and Output Enable (OE1) with selectable jumpers are shown on the ATF15xx-DK3 Base Board of the AT18F-DK3 kit. However, these components were designed for other Atmel adapter boards such as the ATF15xx Series CPLDs and they are not intended to be used with ATF15xxDK3-SAX20 socket adapter for AT18F Series Configurators. Therefore, there is no detailed description about these components in this user guide, if you need additional information, see the ATF15xx-DK3 Kit user guide.

Figure 2-5. Circuit Diagram of Push-button Switches and Selectable Jumpers for GCLR and OE1

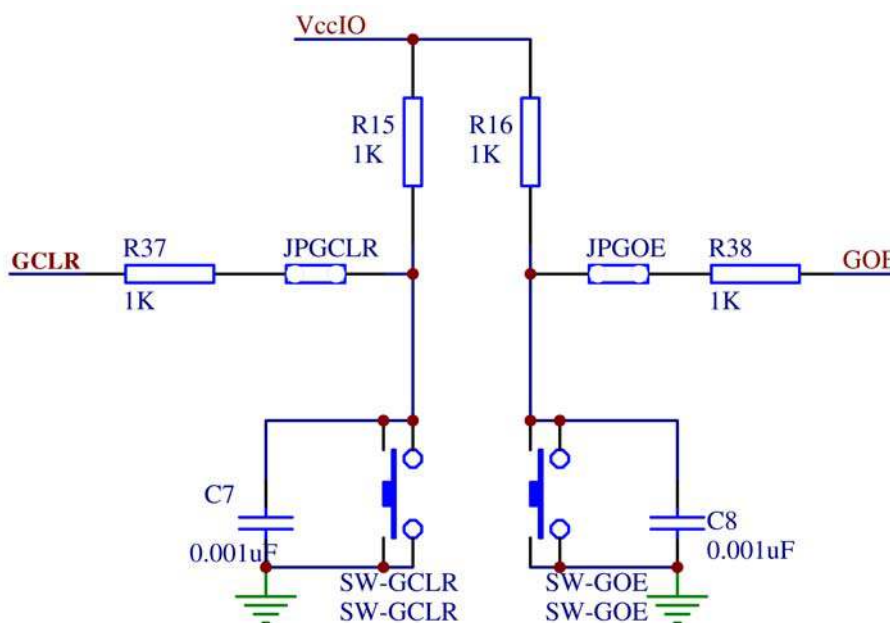

2.1.5 2 MHz Oscillator and Clock Selection Jumper

The 2 MHz Oscillator and Clock Selection Jumper, JP-GCLK, are shown on the ATF15xx-DK3 Base Board of the AT18F-DK3 Kit. However, these components are designed for other adapter boards to be used with Atmel ATF15xx Series CPLDs, and they are not intended to use with ATF15xxDK3-SAX20 socket adapter for AT18F Series Configurators. Therefore, there is no detailed description about these components in this document, but user can always reference ATF15xx-DK3 user guide for more information.

Figure 2-6. Circuit Diagram of Oscillator and Clock Selection Jumper

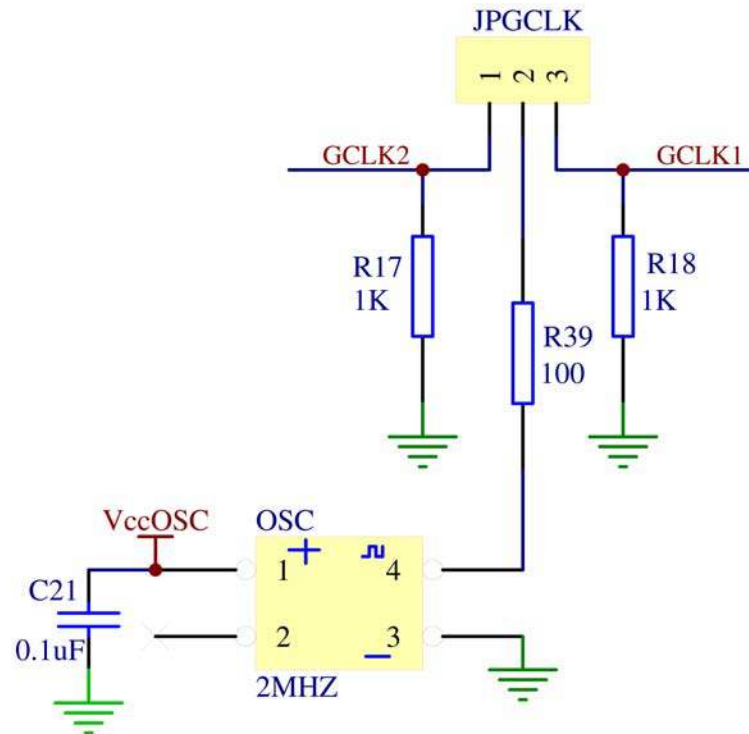

2.1.6 VCCIO and VCCINT Voltage Selection Jumpers and LEDs

The VCCIO and VCCINT Voltage Selection Jumpers, labeled VCCIO Selector and VCCINT Selector, respectively on ATF15xx-DK3 Base Board of the AT18F-DK3 kit are used to select voltage supply to the device and to the JTAG connector. VCCIO voltage is used to set the I/O interface voltage (VCCO) and JTAG programming voltage (VCCJ) of the AT18F Series Configurator. Also, VCCINT voltage jumper is used to set the Core supply voltage of the AT18F Series device. When programming the AT18F Series Configurator with the ATF15xxDK3-SAX20 adapter board, it is required to set both the VCCIO voltage selector jumper and VCCINT voltage selection jumper to 3.3V.

Note: The power of the ATF15xx-DK3 Base Board MUST BE turned OFF when changing the position of the VCCIO or VCCINT voltage selection jumper (VCCIO Selector or VCCINT Selector).

Hardware Description

2.1.7 ICCIO and ICCINT Jumpers

The ICCIO and ICCINT jumpers can be removed and used as ICC measurement points. When the jumpers are removed, current meters can be connected to the posts to measure the current consumption of the target AT18F Series Configurators. When users are not using these jumpers to measure the current, these jumpers must be set in order for the board and Configurator to operate.

2.1.8 Voltage Regulators

Two voltage regulators, labeled VR1 and VR2, are used to independently generate and regulate the VCCINT and VCCIO voltages from the 9V DC power supply. For details, please review the schematic of the ATF15xx-DK3 Base Board of the AT18F-DK3 kit.

2.1.9 Power Supply Switch and Power LED

The Power Supply Switch, labeled POWER SWITCH, can be switched to the ON or OFF position, which is used to turn on or off the power of the ATF15xx-DK3 Base Board of the AT18F-DK3 kit. It allows the 9V DC voltage at the Power Supply Jack to pass to the voltage regulators when it is in the ON position. When the Power Supply Switch is turned ON, the Power LED (labeled POWER LED) will light up to indicate that the ATF15xx-DK3 Base Board of the AT18F-DK3 kit is supplied with power.

2.1.10 Power Supply Jack and Power Supply Header

The Atmel ATF15xx-DK3 Base Board of the AT18F-DK3 kit contains two different types of power supply connectors labeled JPower and JP Power. Either one of these power supply connectors can be used to connect a 9V DC power source to the board. The first power connector, labeled JPower, is a barrel power jack with a 2.1 mm diameter post and it mates to a 2.1 mm (inner diameter) x 5.5 mm (outer diameter) female plug. The second is the power supply header, labeled JP Power, is a 4-pin male 0.1-inch header with 0.025-inch square posts. The availability of these two types of power connectors allows the users to choose the type of power supply equipment to use for ATF15xx-DK3 Base Board of the AT18F-DK3 kit. However, please note that only one of these two power supply connectors should be powered with a 9V DC source but not both at the same time.

2.1.11 JTAG ISP Connector and TDO Selection Jumper

The JTAG ISP Connector, labeled JTAG-IN, is used to connect the ATF15xx's JTAG port pins (TCK, TDI, TMS and TDO) through the ISP download cable to the parallel printer (LPT) port of a PC for JTAG ISP programming of the AT18F Series Configurators. Polarized connectors are used on the ATF15xx-DK3 Base Board of the AT18F-DK3 kit and ISP Download Cable (ATDH1151VPC) Rev 6.0 or later are used to minimize connection problems. The PIN1 label at the bottom of the JTAG ISP connector indicates the pin 1 position of the 10-pin header and further reduces the chance of connecting the ISP Download Cable incorrectly.

To the left of the JTAG-IN connector, there are two columns of vias and they are labeled JTAG-OUT. They are intended to allow the users to create a JTAG daisy chain to perform JTAG operations to multiple AT18F Series Configurators. Users will need to solder the same type of connector as the one used for JTAG-IN into the JTAG-OUT position in order to utilize this available feature.

To create a JTAG daisy chain using multiple ATF15xx-DK3 Base Boards of the AT18F-DK3 kits, the TDO Selection Jumper, labeled JP-TDO, must be set to the appropriate position. For all the devices in the daisy chain except the last device, this jumper must be set to the “TO NEXT DEVICE” position. For the last device in the chain, this jumper must be set to the “TO ISP CABLE” position. When this jumper is in the “TO NEXT DEVICE” position, the TDO of that particular JTAG device will be connected to the TDI of the next JTAG device in the chain. When this jumper is in the “TO ISP CABLE”, the TDO of that device will be connected to the TDO of the JTAG 10-pin connector, which will allow the TDO signal of the that device in the chain to be transmitted back to the host PC with the ISP software. Figure 2-7 below is a circuit diagram of the JTAG connectors and the JP-TDO jumper. For a single device setup, the position of the JP-TDO jumper must be set to “TO ISP CABLE”.

Figure 2-7. Circuit Diagram of the JTAG ISP Connectors and TD Jumper

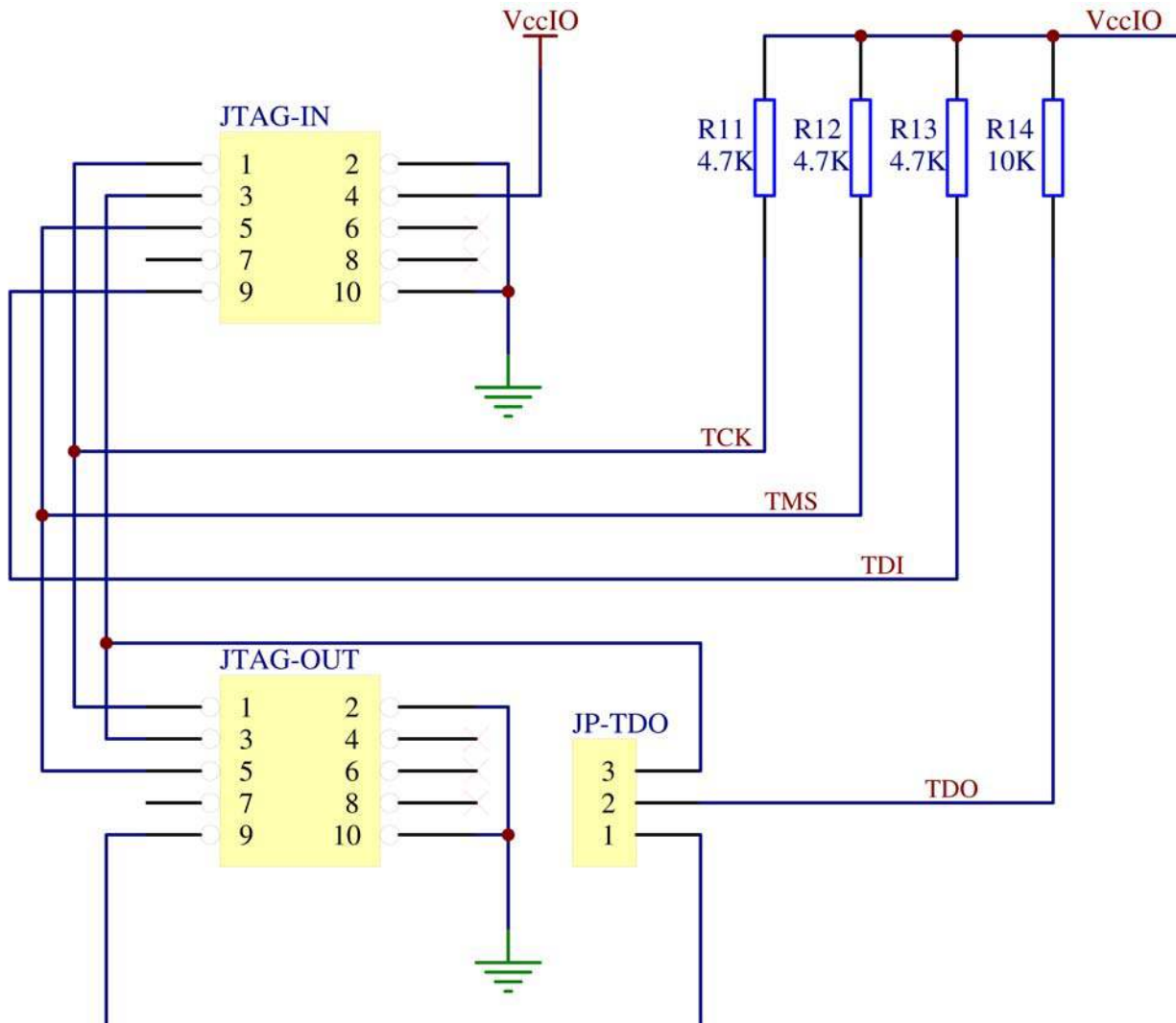

Hardware Description

The ISP algorithm is controlled by the JCPS (JTAG Configurator Programming System) software, which is running on the PC. The four JTAG signals are generated by the LPT port and they are buffered by the ISP download cable before going into the ATF15xx-DK3 Base Board of the AT18F-DK3 kit. The pinout for the 10-pin JTAG Port Header on the ATF15xx-DK3 Base Board is shown in [Figure 2-8](#) and the dimensions of this 10-pin male JTAG header are shown in [Figure 2-9](#).

Figure 2-8. Pinout Diagram of 10-pin JTAG Port Header (Top-view)

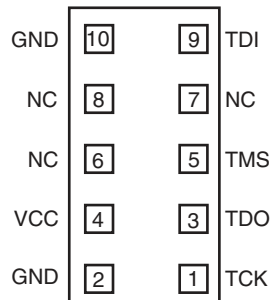
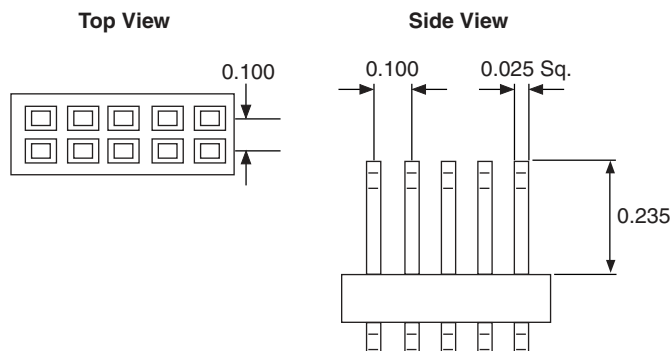

Figure 2-9. 10-pin Male Header Dimensions



- Notes:
1. All dimensions are in inches.
 2. Pitch = 1-inch = 2.54 mm

For In-System programming of the AT18F Series Configurators on the user's FPGA target board, a different JTAG ISP header might be used. Figure 2-10 shows the pinout diagram for a different ISP header that could be used on the target board, and the dimensions of this 14-pin male JTAG header are shown in Figure 2-11.

Figure 2-10. Pinout Diagram of 14-pin JTAG Port Header (Top-view)

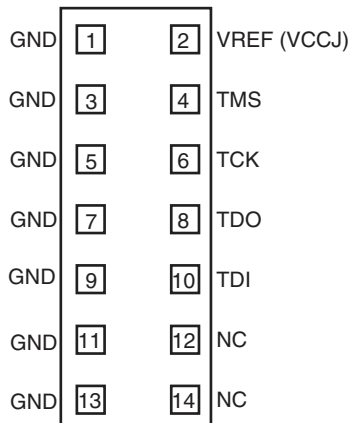
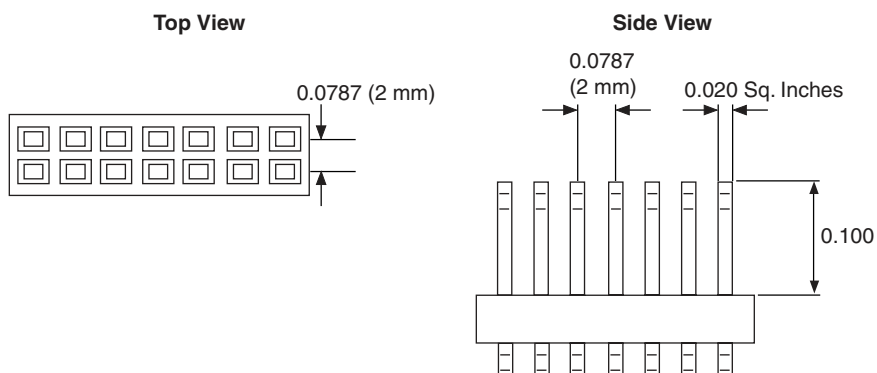

Figure 2-11. 14-pin Male Header Dimensions



- Notes:
1. All dimensions are in inches.
 2. Pitch = 0.0787 inches = 2.00 mm

The ISP cable converter that is included in AT18F-DK3 kit can be used to convert the Atmel 10-pin JTAG ISP header with 2.54 mm pitch to a 14-pin JTAG ISP header with 2.0 mm pitch.

2.2 Socket Adapter Board

Atmel ATF15xxDK3-SAX20 Socket Adapter Board contains the 20-pin TSSOP socket, which is designed to be used with ATF15xx-DK3 Base Board for programming the Atmel AT18F Series Configurators.

The ATF15xxDK3-SAX20 Socket Adapter board has two male headers on the bottom side, labeled JP1 and JP2. The headers on the bottom side mate with the female headers on the ATF15xx-DK3 Base Board, labeled JP4 and JP3. The JTAG port signals, VCCINT, VCCIO, and GND on the ATF15xx-DK3 Base Board are connected to ATF15xxDK3-SAX20 Socket Adapter Board through these two sets of connectors.

On the top of the 20-TSSOP socket adapter (ATF15xxDK3-SAX20), there are two headers. The pins of these headers are connected to the input and I/O pins of the target AT18F Series Configurators. They can be used to connect to an oscilloscope or logic analyzer to capture the activities of the input and I/O pins of the device. They also can be used to connect the input and I/O pins of the configurator to other external boards or devices for system level evaluation or testing.

2.3 Atmel CPLD ISP Download Cable

The Atmel JTAG ISP Download Cable, which is included in AT18F-DK3 development/programming kit, connects the parallel printer (LPT) port of your PC to the 10-pin JTAG header on the Atmel ATF15xx-DK3 Base Board of the AT18F-DK3 kit or a custom circuit board. This ISP cable acts as a buffer to buffer the JTAG signals between the PC's LPT port and the ATF18 Series device on the circuit board. The Power-On LED on the back of the 25-pin male connector housing indicates that the cable is connected properly. Make sure this LED is turned on before using the Atmel JTAG Configurator Programming System (JCPS) Software.

This ISP cable consists of a 25-pin (DB25) male connector, which is connected to the LPT port of a PC. The 10-pin female plug connects to the 10-pin male JTAG header on the ISP circuit board. The red color stripe on the ribbon cable indicates the orientation of Pin 1 of the female plug. The 10-pin male JTAG header on the ATF15xx-DK3 Base Board is polarized to prevent users from inserting the female plug in the wrong orientation.

The Atmel AT18F-DK3 development/programming kit includes this Atmel ATDH1151VPC JTAG ISP cable v6.0 or above, which can be used to program Atmel AT18F Series Configurators. [Figure 2-12](#) shows the JTAG ISP Cable connection from the parallel port of the PC to the JTAG ISP header of the ATF15xx-DK3 Base Board of the AT18F-DK3 kit.

Figure 2-12. Atmel ISP Cable Connection to ISP Hardware Board/Circuit Board

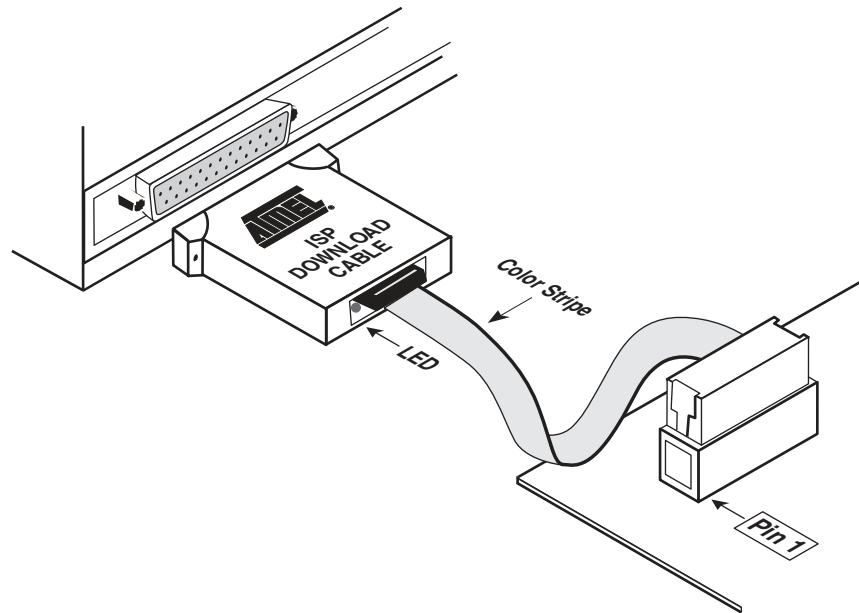
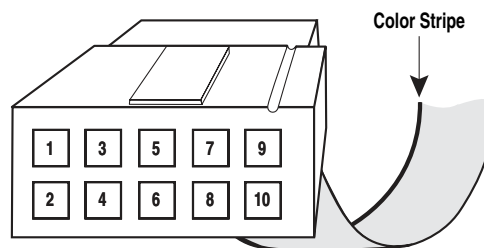

Figure 2-13 shows the pin out for the 10-pin Female header on the Atmel-ISP Cable. The pinout on the 10-pin male header on the PC board (if used for ISP) must match this pinout.

Figure 2-13. Atmel ISP Download Cable 10-pin Female Header Pinout



Note: Your circuit board must supply VCC and GND to the Atmel CPLD ISP Cable through the 10-pin male header. When programming AT18F Series Configurator, VCCIO is used for the ISP Cable

Figure 2-14 shows the different ways to connect Atmel JTAG ISP cable for using different ISP headers in different applications.

Figure 2-14. Atmel ISP Download Cable 10-pin Female Header Pinout

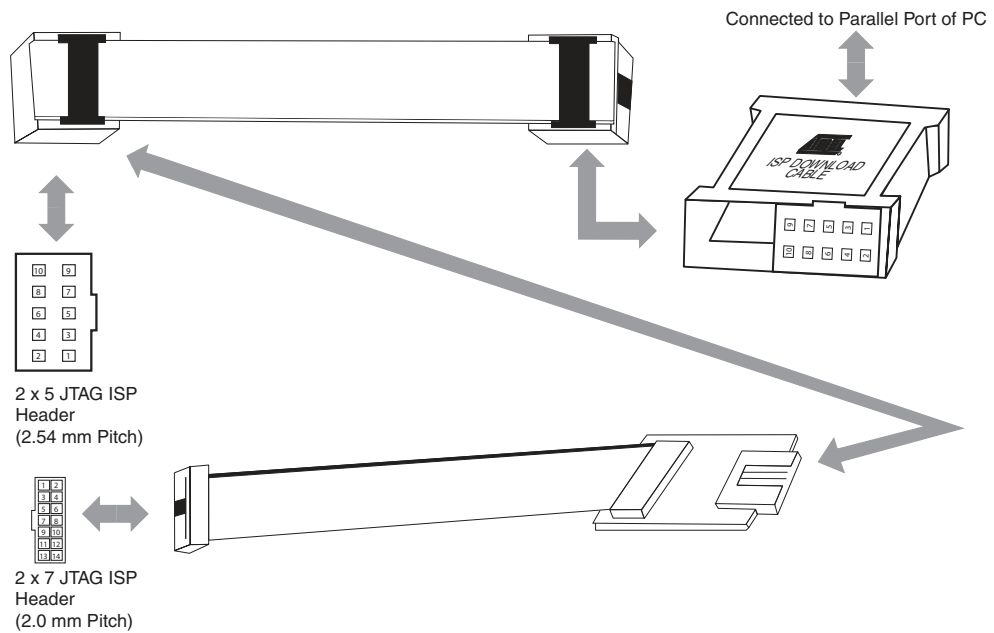

For in-system programming of the AT18F Series Configurator on customer's target board, the 10-pin ISP header (2.54 mm or 1.0-inch pitch) from Atmel JTAG ISP Cable v6.0 or later version can be directly connected to the target board as shown in Figure 2-15 (A), or it can be used with the ISP converter that comes with programmable cable before connecting to the target board with a 14-pin (2.0 mm or 0.0787-inch pitch) ISP header as shown in Figure 2-15 (B). The ISP converter circuit diagram is shown in Section 3, Figure 3-3.

Figure 2-15. Atmel JTAG ISP

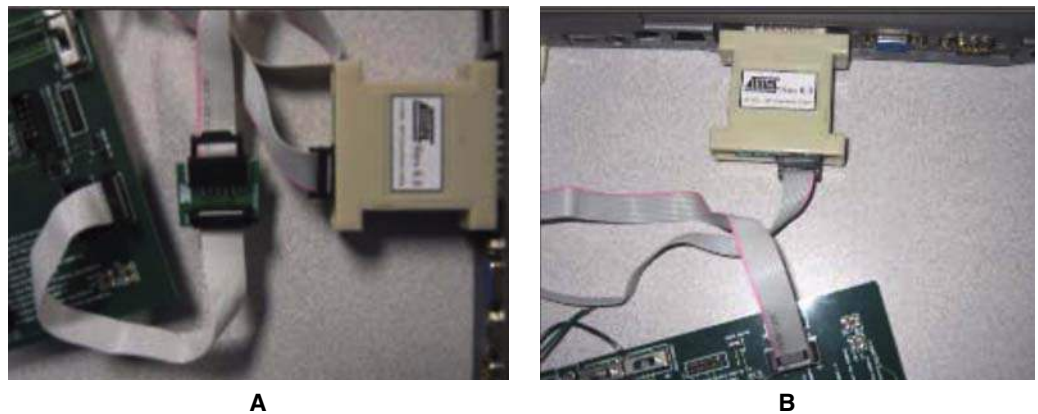

Note: Atmel JCPS software and AT18F-DK3 Programming Kit are designed for development use. For production usage, it is recommended to use industrial stand-alone third-party gang programmers (BP, Hi-Lo, Data I/O, etc.) to program the device. Factory programming is also possible under certain device ordering quantities. For details about factory programming of the device, please contact your local Atmel distribution channel.



Section 3

Schematic Diagrams

Schematic Diagrams

Figure 3-1. Schematic Diagram of ATF15xx-DK3 Base Board

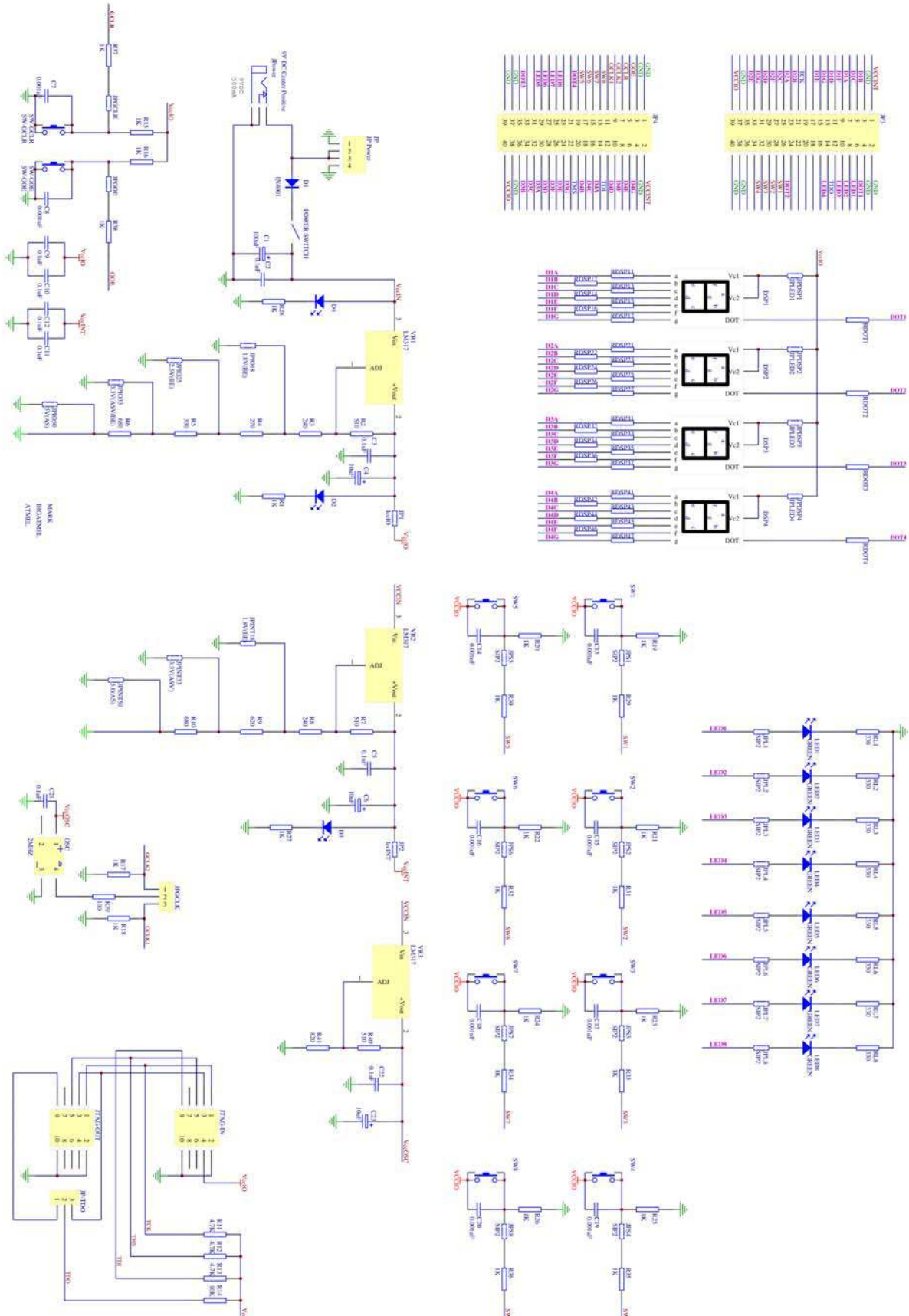
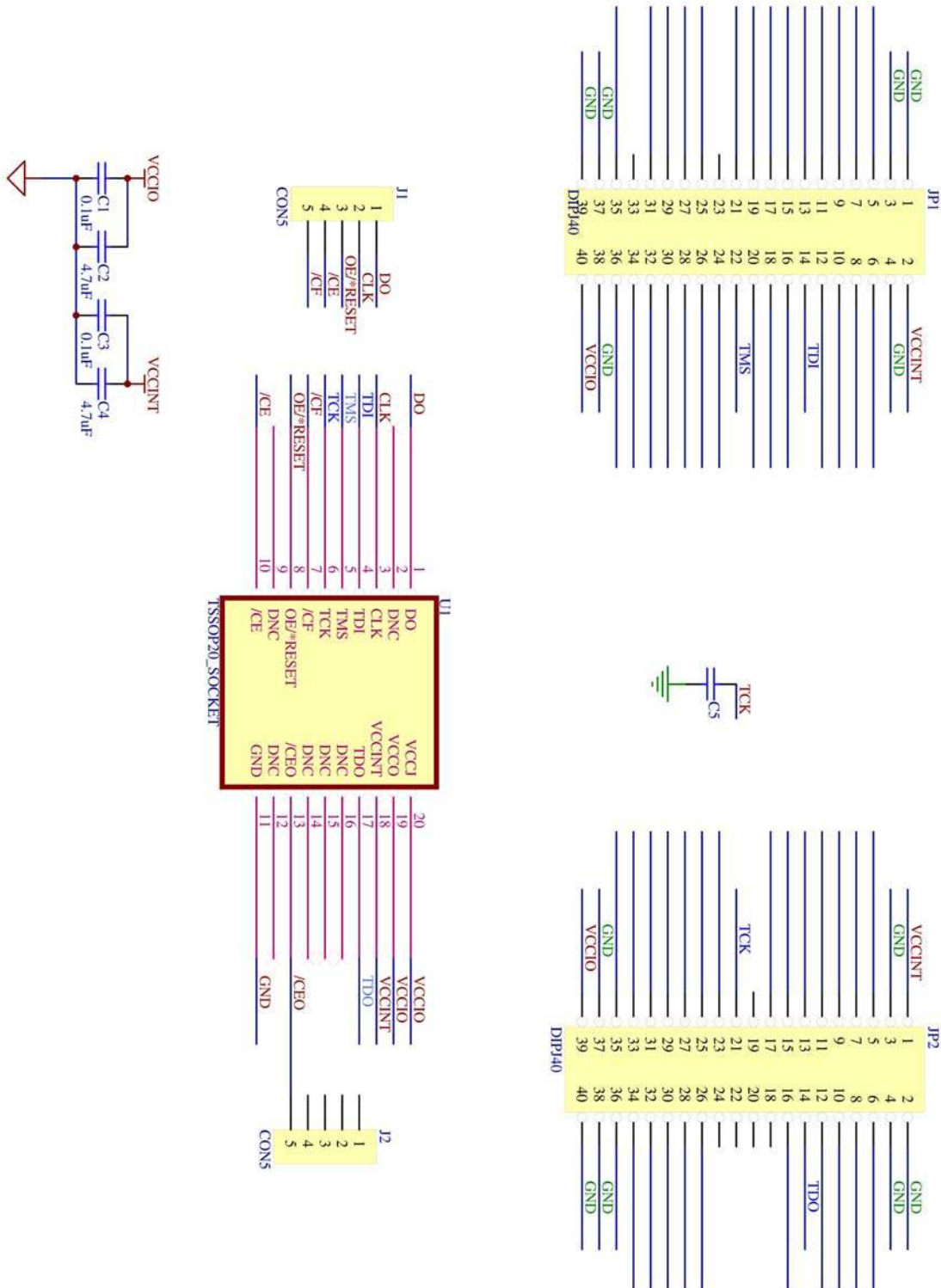
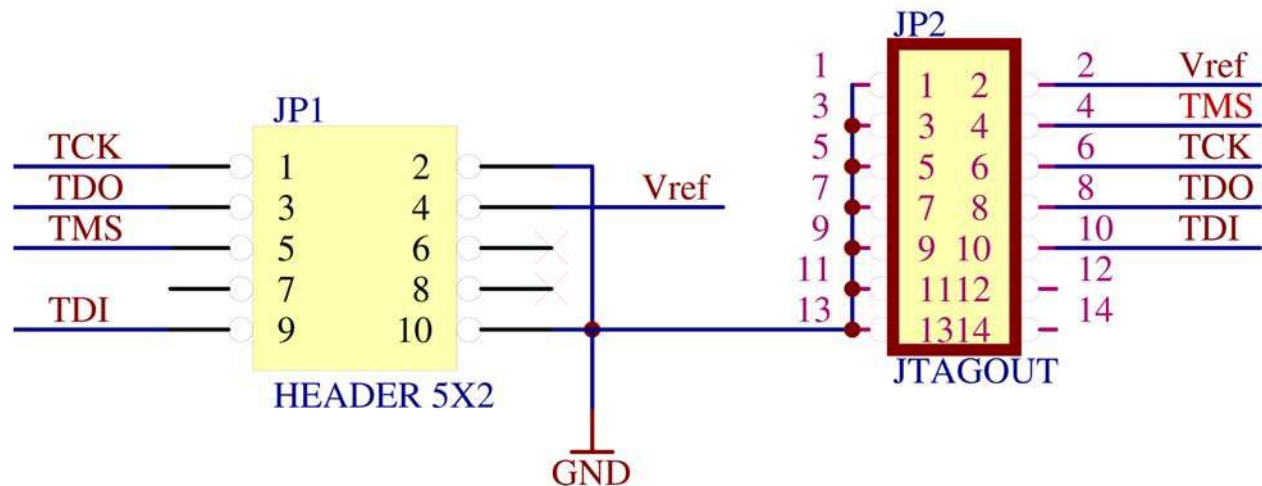

Figure 3-2. Schematic Diagram of ATF15xxDK3-SAX20 (20-lead TSSOP) Adapter Board



Schematic Diagrams

Figure 3-3. Schematic Diagram of ISP Cable Converter





Headquarters

Atmel Corporation
2325 Orchard Parkway
San Jose, CA 95131
USA
Tel: 1(408) 441-0311
Fax: 1(408) 487-2600

International

Atmel Asia
Room 1219
Chinachem Golden Plaza
77 Mody Road Tsimshatsui
East Kowloon
Hong Kong
Tel: (852) 2721-9778
Fax: (852) 2722-1369

Atmel Europe
Le Krebs
8, Rue Jean-Pierre Timbaud
BP 309
78054 Saint-Quentin-en-
Yvelines Cedex
France
Tel: (33) 1-30-60-70-00
Fax: (33) 1-30-60-71-11

Atmel Japan
9F, Tonetsu Shinkawa Bldg.
1-24-8 Shinkawa
Chuo-ku, Tokyo 104-0033
Japan
Tel: (81) 3-3523-3551
Fax: (81) 3-3523-7581

Product Contact

Web Site
www.atmel.com

Technical Support
configurator@atmel.com

Sales Contact
www.atmel.com/contacts

Literature Requests
www.atmel.com/literature

Disclaimer: The information in this document is provided in connection with Atmel products. No license, express or implied, by estoppel or otherwise, to any intellectual property right is granted by this document or in connection with the sale of Atmel products. **EXCEPT AS SET FORTH IN ATMEL'S TERMS AND CONDITIONS OF SALE LOCATED ON ATMEL'S WEB SITE, ATMEL ASSUMES NO LIABILITY WHATSOEVER AND DISCLAIMS ANY EXPRESS, IMPLIED OR STATUTORY WARRANTY RELATING TO ITS PRODUCTS INCLUDING, BUT NOT LIMITED TO, THE IMPLIED WARRANTY OF MERCHANTABILITY, FITNESS FOR A PARTICULAR PURPOSE, OR NON-INFRINGEMENT. IN NO EVENT SHALL ATMEL BE LIABLE FOR ANY DIRECT, INDIRECT, CONSEQUENTIAL, PUNITIVE, SPECIAL OR INCIDENTAL DAMAGES (INCLUDING, WITHOUT LIMITATION, DAMAGES FOR LOSS OF PROFITS, BUSINESS INTERRUPTION, OR LOSS OF INFORMATION) ARISING OUT OF THE USE OR INABILITY TO USE THIS DOCUMENT, EVEN IF ATMEL HAS BEEN ADVISED OF THE POSSIBILITY OF SUCH DAMAGES.** Atmel makes no representations or warranties with respect to the accuracy or completeness of the contents of this document and reserves the right to make changes to specifications and product descriptions at any time without notice. Atmel does not make any commitment to update the information contained herein. Unless specifically provided otherwise, Atmel products are not suitable for, and shall not be used in, automotive applications. Atmel's products are not intended, authorized, or warranted for use as components in applications intended to support or sustain life.

© 2008 Atmel Corporation. All rights reserved. Atmel®, logo and combinations thereof, and others are registered trademarks or trademarks of Atmel Corporation or its subsidiaries. Windows® and others are registered trademarks or trademarks of Microsoft Corporation in US and other countries. Other terms and product names may be trademarks of others.