

NOTES

- 製品詳細寸法については製品単体図面を参照下さい。  
DETAIL DIMENSION SEE PRODUCT DRAWING.
- 梱包数量：3000個 / リール  
NUMBER OF CONNECTORS : 3000 PCS/REEL.
- リードテープ長さ LEAD TAPE LENGTH.

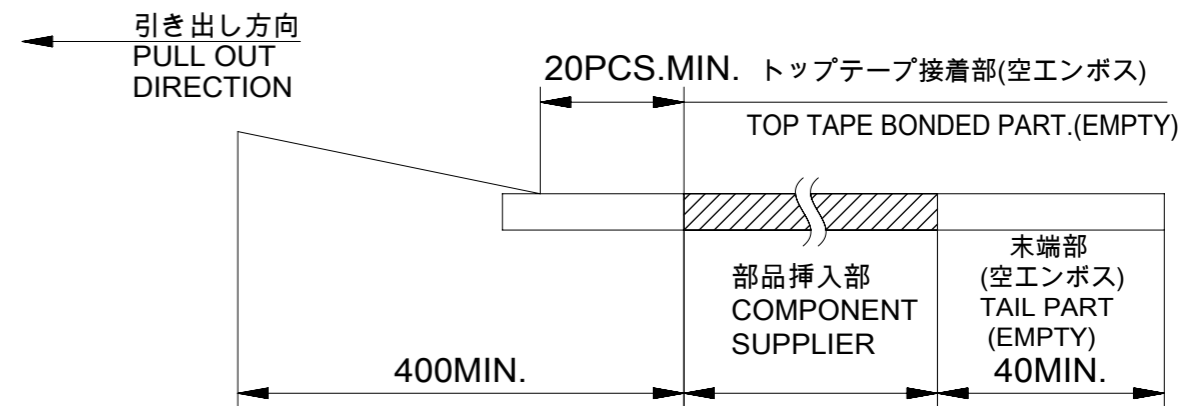

- トップテープの剥離強度：0.1N～1.3N(10gf～130gf)(剥離方向は下図参照)尚、本規格値は出荷時に適用。(但し、輸送時に剥離が発生しないこと。)  
PEELING OFF FORCE OF TOP TAPE : 0.1N ~ 1.3N(10gf ~ 130gf)  
(PEELING DIRECTION AS SHOWN IN FOLLOWING FIG.)  
THIS REQUIREMENT SHOULD BE APPLIED AT SHIPMENT.  
PEEL OFF SHOULD NOT BE ALLOWED, DURING TRANSPORTATION.

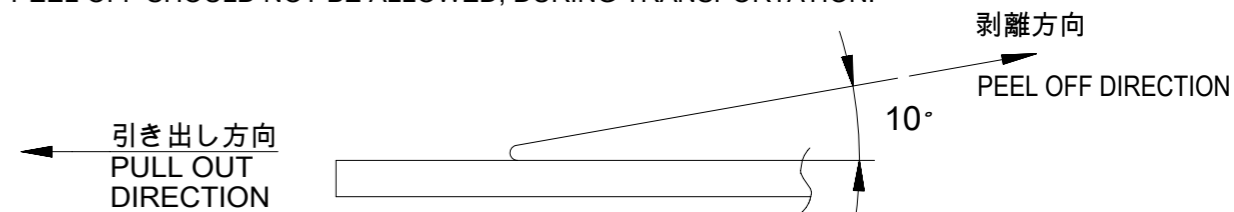

- 材料 MATERIAL  
キャリアテープ(CARRIER TAPE) : ポリスチレン (POLYSTYRENE)  
トップテープ(TOP TAPE) : PET, OTHER  
リール (REEL) : ポリスチレン(PS)<リサイクル材を含む>

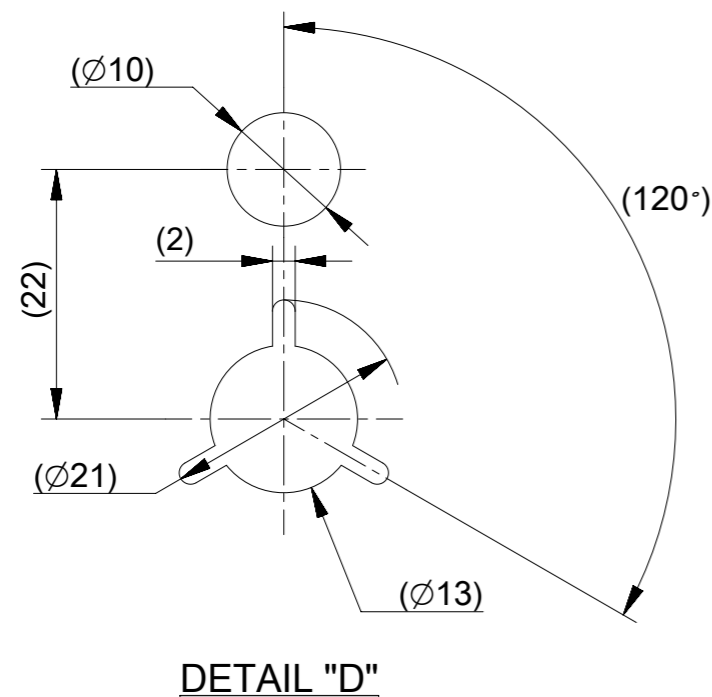
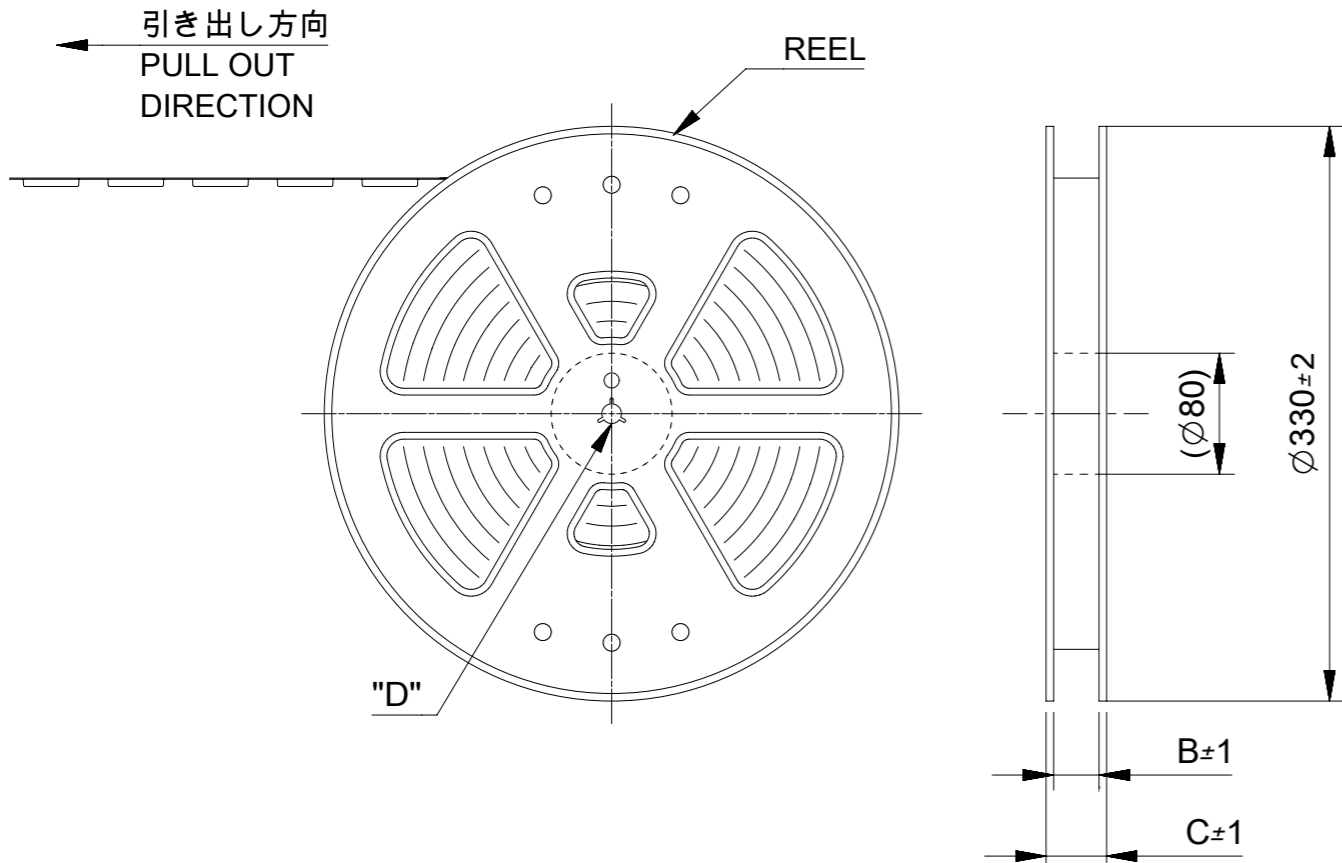

MODEL NO. 503552\*\*80

THIS DRAWING CONTAINS INFORMATION THAT IS PROPRIETARY TO MOLEX ELECTRONIC TECHNOLOGIES, LLC AND SHOULD NOT BE USED WITHOUT WRITTEN PERMISSION											
EC NO: 118757 DRWN: TMIYAZAKI CHK'D: KTAKAHASHI APPR: MSASAO	2017/06/29	2017/06/29	2017/06/30	GENERAL TOLERANCES (UNLESS SPECIFIED)	DIMENSION UNITS	SCALE					
					MM	NTS					
					DRWN BY	DATE				TMIYAZAKI	2017/05/18
					CHK'D BY	DATE				KTAKAHASHI	2017/06/08
					APPR BY	DATE				MSASAO	2017/06/09
				DRAFT WHERE APPLICABLE MUST REMAIN WITHIN DIMENSIONS	DRAWING SIZE	THIRD ANGLE PROJECTION	PRODUCT CUSTOMER DRAWING				
					A3		SERIES	MATERIAL NUMBER	CUSTOMER		
							503552	SEE SHEET 2	GENERAL		
							DOCUMENT NUMBER	DOC TYPE	DOC PART	SHEET NUMBER	
							5035520000	PSD	001	1 OF 2	

THIS DOCUMENT HAS BEEN RE-ISSUED BASED ON SD-503552-008, REV 0

RELEASE STATUS P1 RELEASE DATE 30.06.2017 07:11:03

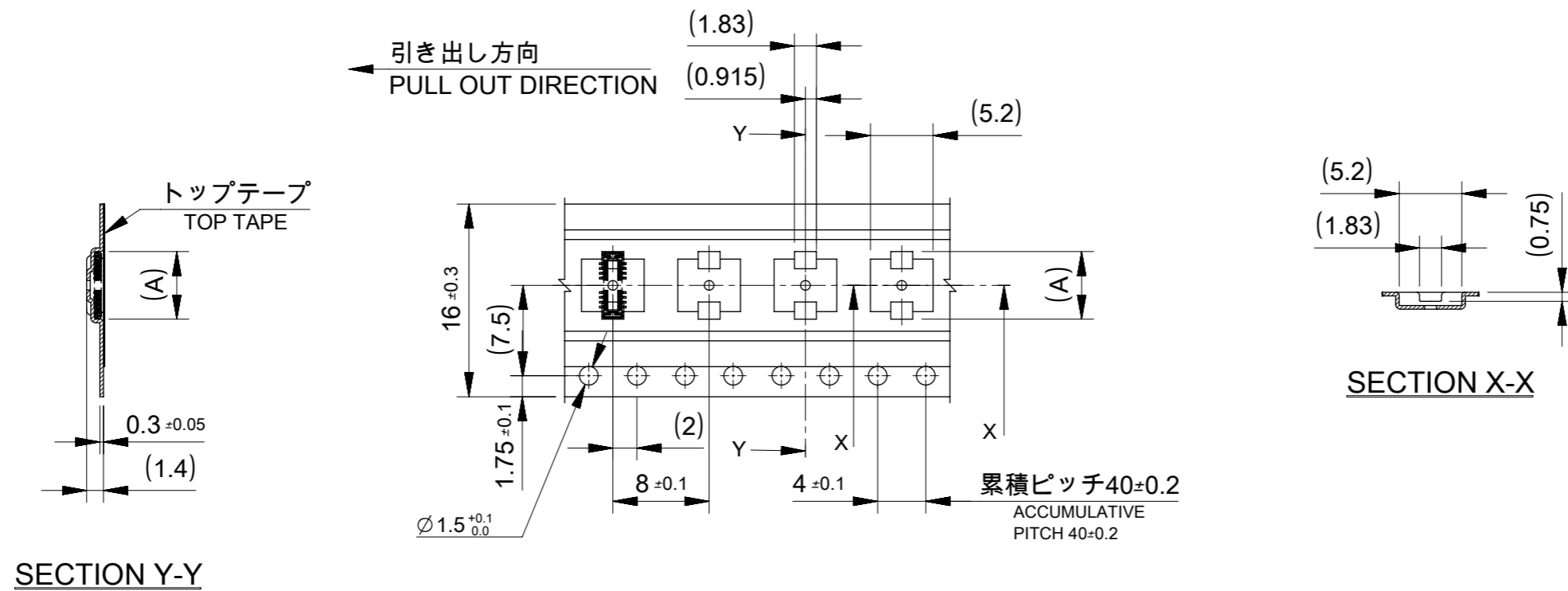

16mm 幅キャリアテープ  
16mm WIDTH CARRIER TAPE

16	21.4	17.4	5.21	5035521880	18
			4.81	5035521680	16
			4.41	5035521480	14
			4.01	5035521280	12
			2.81	5035520680	6
キャリアテープ幅 CARRIER TAPE WIDTH			C	B	(A)
			MATERIAL No.	CKT.	
			MODEL No. 503552**80		

THIS DRAWING CONTAINS INFORMATION THAT IS PROPRIETARY TO MOLEX ELECTRONIC TECHNOLOGIES, LLC AND SHOULD NOT BE USED WITHOUT WRITTEN PERMISSION

EC NO: 118757 DRWN: TMIYAZAKI CHK'D: KTAKAHASHI APPR: MSASAO	2017/06/29	2017/06/29	2017/06/30	GENERAL TOLERANCES (UNLESS SPECIFIED) ANGULAR TOL ± ° 4 PLACES ± 3 PLACES ± 2 PLACES ± 1 PLACE ± 0 PLACES ± DRAFT WHERE APPLICABLE MUST REMAIN WITHIN DIMENSIONS	DIMENSION UNITS	SCALE		
					MM	NTS		
					DRWN BY	DATE		0.4 B-TO-B CONN. HGT=0.7 HI-RETENTION PLUG ASSY CHECKER TYPE EMBSTP PKG
					TMIYAZAKI	2017/05/18		
					CHK'D BY	DATE		
					KTAKAHASHI	2017/06/08		
			APPR BY	DATE	PRODUCT CUSTOMER DRAWING			
			MSASAO	2017/06/09				
			DRAWING SIZE	THIRD ANGLE PROJECTION	SERIES	MATERIAL NUMBER	CUSTOMER	
			A3		503552	SEE CHART	GENERAL	
					DOCUMENT NUMBER	DOC TYPE	DOC PART	SHEET NUMBER
					5035520000	PSD	001	2 OF 2

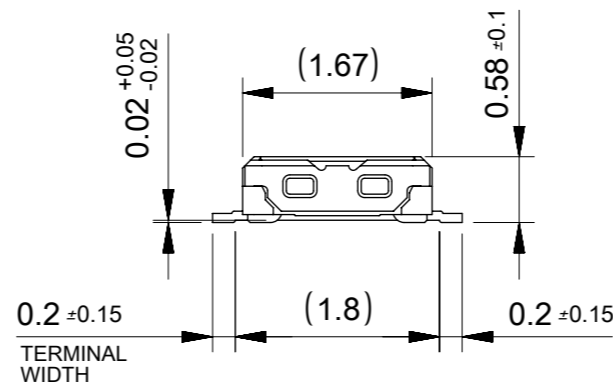
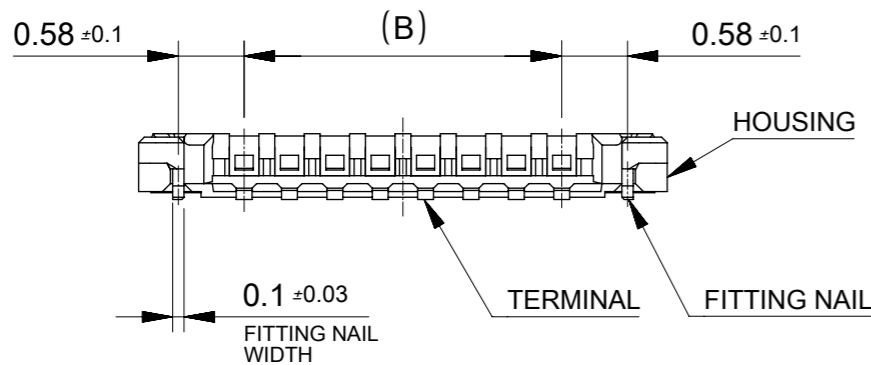
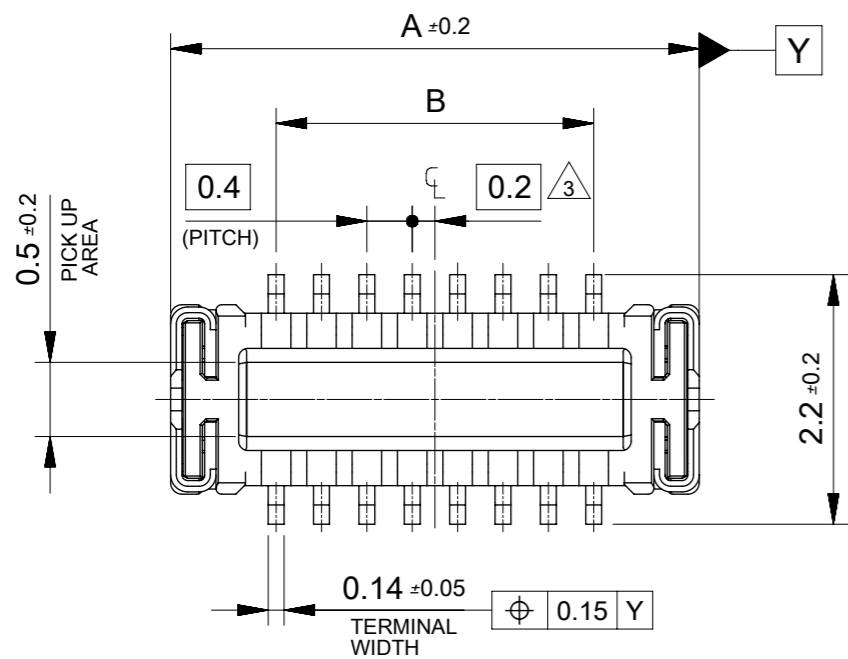

注記 NOTES

1. 使用材料 MATERIAL  
 ハウジング : 液晶ポリマー ( LCP ) UL94V-0 ( 黒 )  
 HOUSING: LIQUID CRYSTAL POLYMER UL94V-0 ( COLOR:BLACK)  
 ターミナル : 銅合金  
 TERMINAL : COPPER ALLOY  
 金具 : 銅合金  
 FITTING NAIL : COPPER ALLOY
2. メッキ仕様 PLATING  
 ターミナル TERMINAL  
 金メッキ GOLD  
 下地メッキ : ニッケルメッキ  
 UNDER PLATING : NICKEL  
 ※コンタクト部とテール部はニッケルメッキによって分断されている金メッキです。  
 DIVIDE INTO PARTS THE GOLD PLATING OF CONTACT  
 AND THE TAIL PART BY THE NICKEL PLATING  
 金具 FITTING NAIL  
 金メッキ ( テール部のみ ) GOLD ( ONLY TAIL PART )  
 下地メッキ : ニッケルメッキ  
 UNDER PLATING : NICKEL
- △3 ( 全極数 / 2 ) = 偶数の場合に適用。  
 APPLY FOR (CIRCUIT/2)=EVEN.
4. 嵌合相手 : 503548 シリーズ  
 MATE WITH : 503548 SERIES.
5. テール平坦度は、0.08 以下  
 テール及び金具の平坦度は、0.1 以下  
 TAIL COPLANARITY TO BE 0.08MAXIMUM.  
 TAIL AND FITTING NAIL COPLANARITY TO BE 0.1MAXIMUM.

3.2±0.2	5.06	5035521880	18
2.8±0.2	4.66	5035521680	16
2.4±0.2	4.26	5035521480	14
2.0±0.2	3.86	5035521280	12
0.8±0.1	2.66	5035520680	6
B	A	EMBOSSED PACKAGE オーダー番号 ORDER No.	極数 CIRCUITS
CONNECTOR SERIES No.: 503552**89			

THIS DRAWING CONTAINS INFORMATION THAT IS PROPRIETARY TO MOLEX ELECTRONIC TECHNOLOGIES, LLC AND SHOULD NOT BE USED WITHOUT WRITTEN PERMISSION

EC NO: 118757 DRWN: TMIYAZAKI CHK'D: KTAKAHASHI APPR: MSASAO	2017/06/29	2017/06/29	2017/06/30	GENERAL TOLERANCES (UNLESS SPECIFIED) ANGULAR TOL ± ° 4 PLACES ± 3 PLACES ± 2 PLACES ± 1 PLACE ± 0 PLACES ±	DIMENSION UNITS	SCALE			
					MM	15:1			
					DRWN BY	DATE		TMIYAZAKI	2017/05/18
					CHK'D BY	DATE		KTAKAHASHI	2017/06/08
					APPR BY	DATE		MSASAO	2017/06/09
					DRAWING SIZE	THIRD ANGLE PROJECTION		A3	
DRAFT WHERE APPLICABLE MUST REMAIN WITHIN DIMENSIONS				PRODUCT CUSTOMER DRAWING SERIES: 503552 MATERIAL NUMBER: SEE CHART CUSTOMER: GENERAL DOCUMENT NUMBER: 5035521000 DOC TYPE: PSD DOC PART: 003 SHEET NUMBER: 1 OF 2					

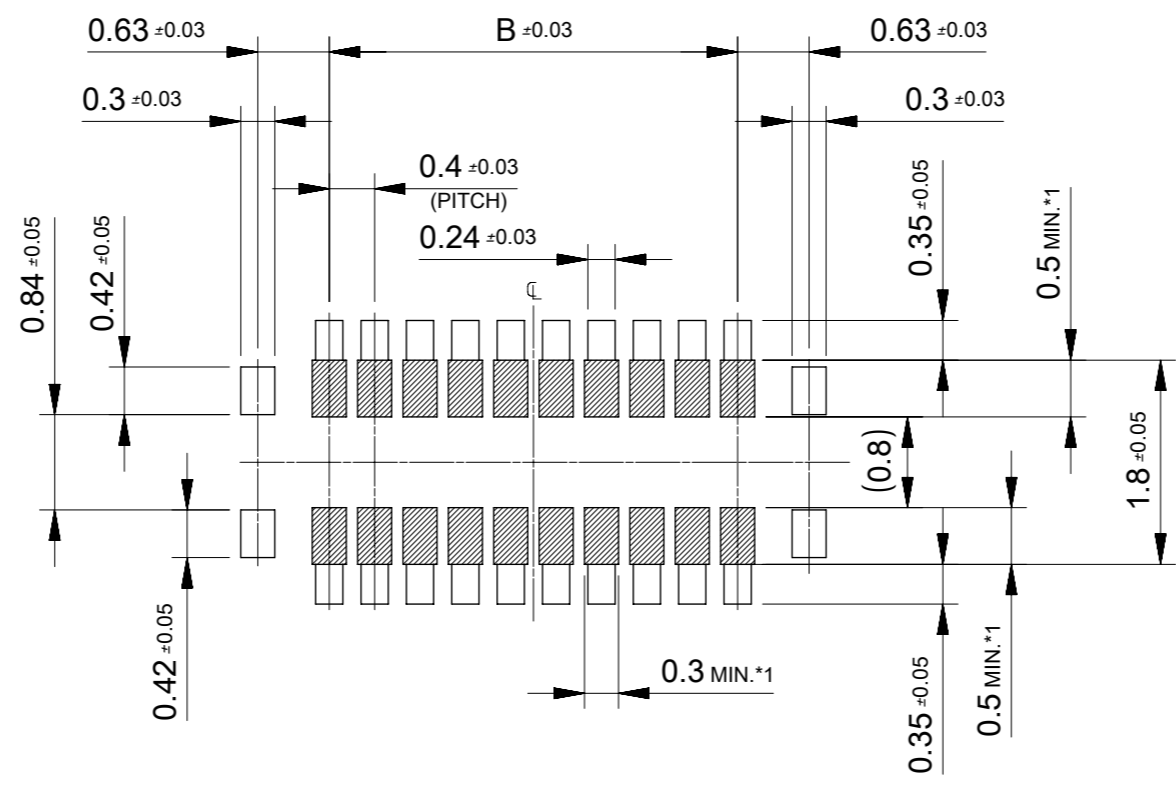

RECOMMENDED P.W. BOARD  
PATTERN LAYOUT

- \*1 パターン引き回し、および半田禁止エリア  
(当該箇所においては、これと接する回路以外の配線を禁止する。  
また、接する回路を配線する場合はレジストを施し、この部分に  
半田は無きこととする。)
- \*1 PROHIBITED AREA OF PATTERN WIRING AND SOLDER.  
(FOR EACH AREA, THE WIRING THAT TOUCHES ON THE SOLDER  
CAN BE ATTACHED, THEN COVERED WITH A FILM TO KEEP SOLDER OUT.)

THIS DRAWING CONTAINS INFORMATION THAT IS PROPRIETARY TO MOLEX ELECTRONIC TECHNOLOGIES, LLC AND SHOULD NOT BE USED WITHOUT WRITTEN PERMISSION										
EC NO: 118757 DRWN: TMIYAZAKI CHK'D: KTAKAHASHI REV APPR: MSASAO	2017/06/29	2017/06/29	2017/06/30	GENERAL TOLERANCES (UNLESS SPECIFIED) ANGULAR TOL ± ° 4 PLACES ± 3 PLACES ± 2 PLACES ± 1 PLACE ± 0 PLACES ±	DIMENSION UNITS	SCALE				
					MM	15:1				
					DRWN BY	DATE				
					TMIYAZAKI	2017/05/18	0.4 B-TO-B CONN. HGT=0.7 W=2.6 HI-RETENTION PLUG ASSY CHECKER TYPE			
					CHK'D BY	DATE				
					KTAKAHASHI	2017/06/08	PRODUCT CUSTOMER DRAWING			
			APPR BY	DATE						
			MSASAO	2017/06/09	SERIES	MATERIAL NUMBER	CUSTOMER			
			DRAFT WHERE APPLICABLE MUST REMAIN WITHIN DIMENSIONS		A3	THIRD ANGLE PROJECTION	503552	SEE SHEET 1	GENERAL	
							DOCUMENT NUMBER	DOC TYPE	DOC PART	SHEET NUMBER
							5035521000	PSD	003	2 OF 2