



# THCV219

V-by-One® HS High-speed video data transmitter

## General Description

THCV219 is designed to support video data transmission between the host and display. One high-speed lane can carry up to 32bit data and 3 bits of synchronizing signals at a pixel clock frequency from 7.5MHz to 75MHz. It has one high-speed data lane and, maximum serial data rate is 3.0Gbps/lane.

Width	Link	TTL Clock Freq.
24bit	Si/So	10MHz to 100MHz
32bit	Si/So	7.5MHz to 75MHz

Si/So : Single-in/Single-out,

## Features

- Color depth selectable: 24(8\*3)/32(10\*3)bit
- Single Link
- AC coupling for high speed lines
- Wide Range Supply Voltage 2.3~3.6V
- Package: 64 pin QFN
- Wide frequency range
- Spread Spectrum Clocking tolerant  
Up to 30kHz±0.5% (center spread)
- V-by-One® HS standard Version1.4 compliant
- AEC-Q100 ESD Protection

## Block Diagram

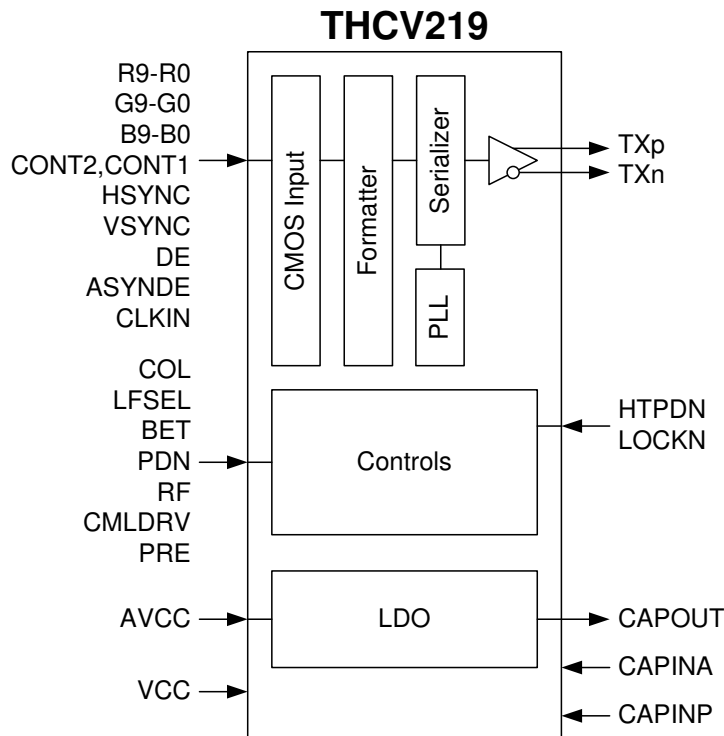

---

Contents Page	
General Description.....	1
Features .....	1
Block Diagram .....	1
Pin Configuration .....	3
Pin Description .....	4
Functional Description .....	5
Absolute Maximum Ratings* .....	10
Recommended Operating Conditions.....	10
Supply Current .....	10
Electrical Specifications .....	11
AC Timing Diagrams and Test Circuits.....	12
Data Mapping .....	15
Package.....	16
Notices and Requests.....	17

Pin Configuration

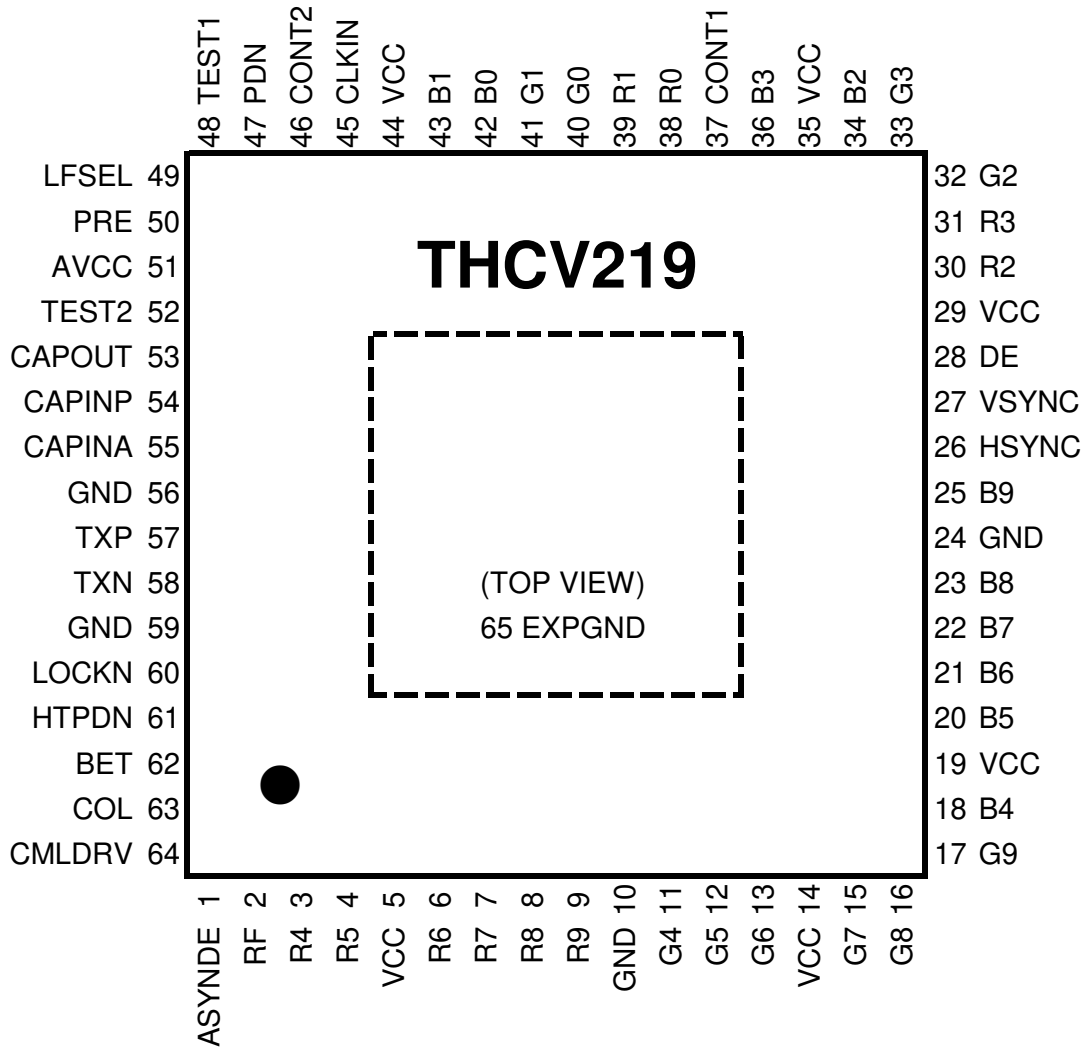

## Pin Description

Pin Name	Pin #	type*	Description
R9-R0	9,8,7,6,4, 3,31,30,39,38	I3	pixel data inputs
G9-G0	17,16,15,13,12, 11,33,32,41,40	I3	pixel data inputs
B9-B0	25,23,22,21,20, 18,36,34,43,42	I3	pixel data inputs
CONT1,2	37,46	I3	User defined data inputs. Active only in 32bit mode.
DE	28	I3	DE input
VSYNC	27	I3	Vsync input
HSYNC	26	I3	Hsync input
CLKIN	45	I3	Pixel clock input
TXNP	58,57	CO	High-speed CML signal output.
LOCKN	60	I3L	Lock detect input. Must be connected to Rx LOCKN with a 10kΩ pull-up resistor.
HTPDN	61	I3L	Hot plug detect input. Must be connected to Rx HTPDN with a 10kΩ pull-up resistor.
PDN	47	I3L	Power down input. H: Normal operation L: Power down
PRE	50	I3	Pre-Emphasis level select input. H: Pre-Emphasis Enable L: Pre-Emphasis Disable
CMLDRV	64	I3	CML Outputs drive strength select input. H: Normal drive strength L: Weak drive strength
COL**	63	I3	Data width setting. H: 24bit L: 32bit
LFSEL**	49	I3	Frequency range setting. H: Low frequency operation L: Normal Operation
ASYNDE	1	I3	Asynchronous DE input. H: Normal operation (ASYNDE function disable) L: DE input invert operation (ASYNDE function enable)
RF	2	I3	Input clock triggering edge select input for latching input data H: Rising edge L: Falling edge
BET	62	I3	Field-BET entry. H: Field BET Operation L: Normal Operation
TEST1	48	-	Test pin, must be "L" for normal operation.
TEST2	52	-	Test pin, must be "L" for normal operation.
CAPOUT	53	-	Decoupling capacitor pins. This pin should be connected to external decoupling capacitors. Recommended Capacitance is 2.2uF
CAPINP	54	-	Reference Input for PLL circuit. Must be tied CAPOUT.
CAPINA	55	-	Reference Input for Analog circuit. Must be tied CAPOUT.
VCC	5,14,19,29, 35,44	PS	Digital Power supply Pins
AVCC	51	PS	Analog Power supply Pin
GND	10,24,56,59	PS	Ground Pins
EXPGND	65	PS	Exposed Pad Ground

\*type symbol

I3=3.3v CMOS input, I3L=Low Speed 3.3v CMOS input

CO=CML output, PS=Power Supply

\*\*COL, LFSEL pin

COL pin and/or LFSEL pin level shall not be changed during operation. If either pin level is changed during operation, PDN shall be toggled (H-> L -> H) after the change.

## Functional Description

### Functional Overview

With V-by-One® HS proprietary encoding scheme and CDR (Clock and Data Recovery) architecture, THCV219 enables transmission of 8/10 bit RGB, 2bits of user-defined data (CONT), synchronizing signals HSYNC, VSYNC, and DE by a pair cable with minimal external components.

THCV219 inputs CMOS/TTL data (including video data, CONT, HSYNC, VSYNC, and DE) and serializes video data and synchronizing signals separately, depending on the polarity of DE. DE is a signal which indicates whether video or synchronizing data are active. When DE is high, it serializes video data inputs into differential data streams. And it transmits serialized synchronizing data when DE is low.

THCV219 can operate for a wide range of a serial bit rate from 600Mbps to 3.0Gbps. It does not need any external frequency reference, such as a crystal oscillator.

### Internal Reference Output/Input Function (CAPOUT,CAPINA,CAPINP)

An internal regulator produces the 1.2V (CAPOUT). This 1.2V linear regulator can not supply any other external loads. Bypass CAPOUT to GND with 2.2uF.

CAPINP supplies reference voltage for internal PLL, and CAPINA supplies reference voltage for any internal analog circuit. Bypass CAPINP/CAPINA to GND with 0.1uF to remove high frequency noise. CAPOUT, CAPINA and CAPINP must be tied together.

Analog power supply AVCC is supposed to be stabilized with de-coupling capacitor and series noise filter (for example, ferrite bead).

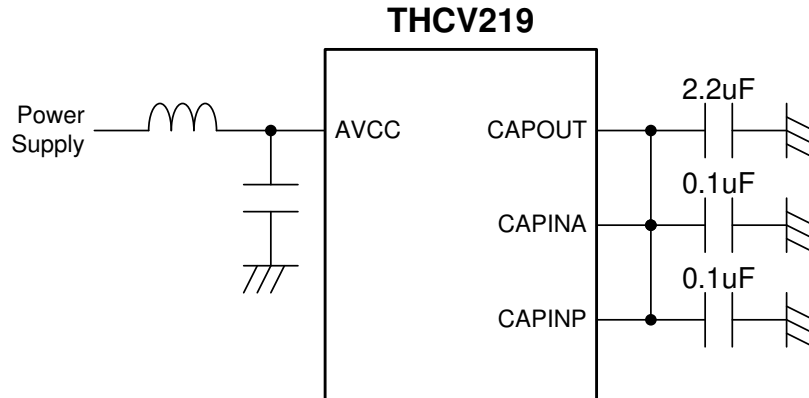

Figure 1. Connection of CAPOUT, CAPINA, CAPINP and Decoupling Capacitor

**Data Enable**

Figure 2 is the conceptual diagram of the basic operation of the chipset. THCV220 in Figure 2 is an example of V-by-One® HS Receiver.

There are some requirements for DE. Figure 3 shows the timing diagram of it.

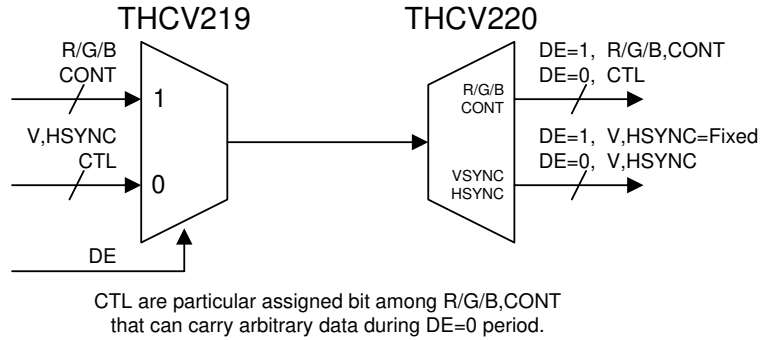

Figure 2. Conceptual diagram of the basic operation of the chipset

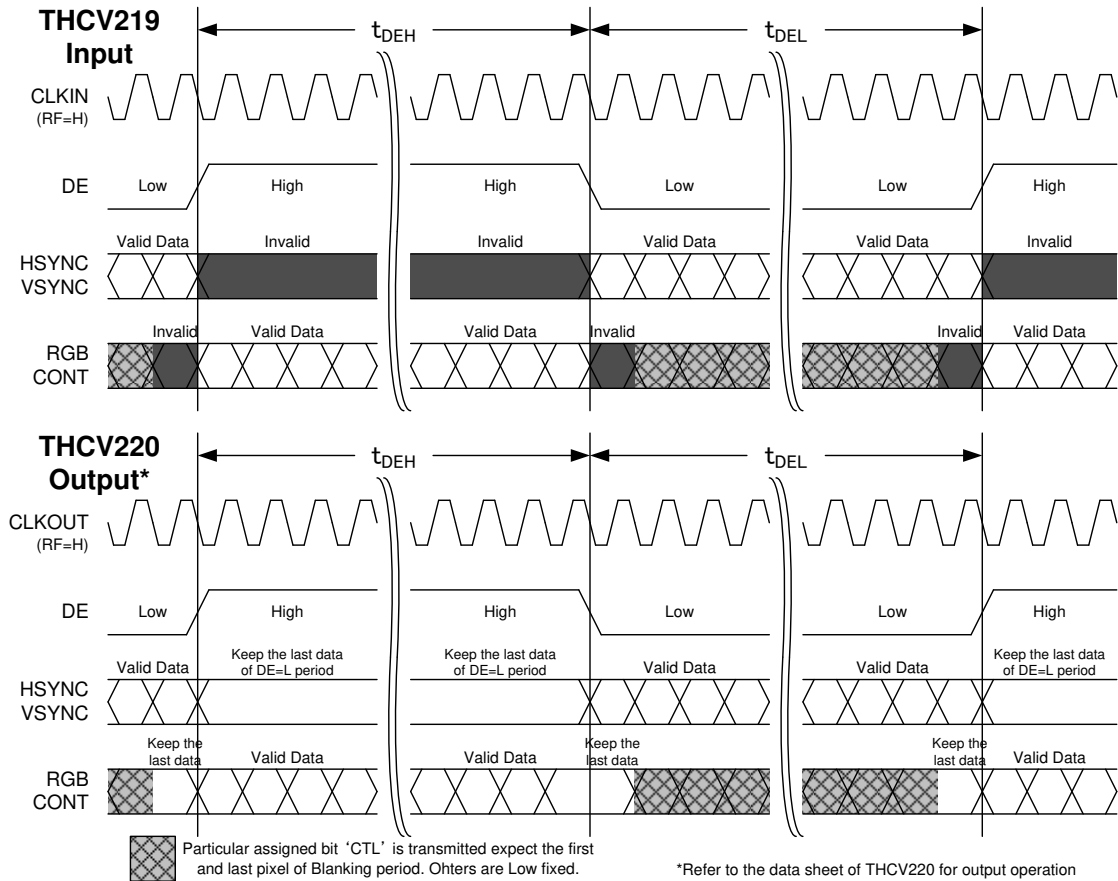

Figure 3. Data and synchronizing signals transmission timing diagram

Table 1. DE requirement

symbol	Parameter	min.	typ.	max.	Unit
tDEH	DE=High Duration	2tTCIP			sec
tDEL	DE=Low Duration	2tTCIP			sec

**ASYNDE**

If ASYNDE input is Low, DE input is inverted before V-by-One® HS processing. RGB/CONT Data is transmitted during DE input=Low. Please be careful this inverted DE is outputted from V-by-One® HS receiver, which may cause polarity mismatch against following system requirement.

**Color Depth and Frequency Range Select function**

The mode selected by the combination of the COL and LFSEL pin settings is shown in Table 2.

The 32bit mode and 24bit mode correspond to the 4Byte mode and 3Byte mode in the V-by-One® HS standard, respectively.

Low Frequency mode is a THine proprietary feature. To use this mode, a Receiver device with this function must be used. The Receiver device must also be set to Low Frequency mode.

Table 2. operation mode select

COL	LFSEL	Description	Freq. Range(Hz)
L	L	32bit	15 to 75M
	H	32bit Low frequency mode	7.5 to 30M
H	L	24bit	20 to 100M
	H	24bit Low frequency mode	10 to 40M

**Hot-Plug Function**

HTPDN indicates connecting condition between the Transmitter and the Receiver. HTPDN of the transmitter side is high when the Receiver is not active or not connected. Then Transmitter can enter into the power down mode. HTPDN is set to Low by the Receiver when Receiver is active and connects to the Transmitter, and then Transmitter must start up and transmit CDR training pattern for link training. HTPDN is open drain output at the receiver side. Pull-up resistor is needed at the transmitter side.

HTPDN connection between the Transmitter and the Receiver can be omitted as an application option. In this case, HTPDN at the Transmitter side should always be taken as Low.

**Lock Detect Function**

LOCKN indicates whether the CDR PLL is in the lock state or not. LOCKN at the Transmitter input is set to High by pull-up resistor when Receiver is not active or at the CDR PLL training state. LOCKN is set to Low by the Receiver when CDR lock is done. Then the CDR training mode finishes and Transmitter shifts to the normal mode. LOCKN is open drain output at the receiver side. Pull-up resistor is needed at the transmitter side.

When HTPDN is included in an application, the LOCKN signal should only be considered when the HTPDN is pulled low by the Receiver.

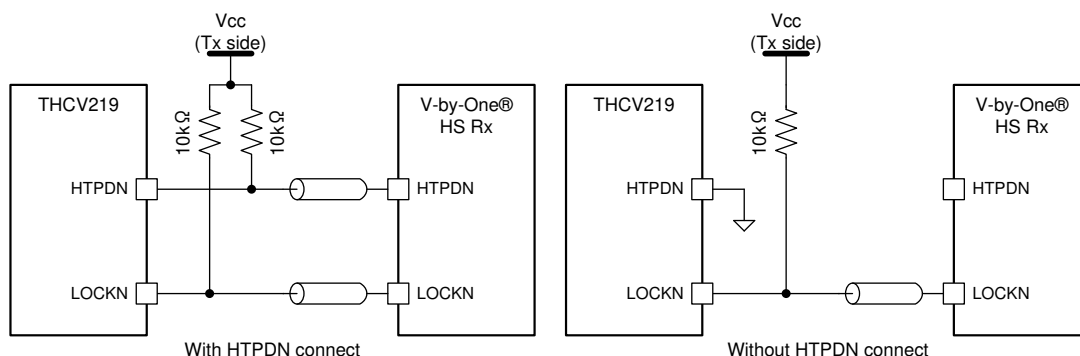

Figure 4. Hot-plug and Lock detect scheme

### Pre-emphasis and Drive Select Function

Pre-emphasis can equalize severe signal degradation caused by long-distance or high-speed transmission. The PRE pin selects the strength of pre-emphasis.

CMLDRV controls CML output swing level. See Table 3.

Table 3. Pre-emphasis and Drive Select function table

PRE	CMLDRV	Description	
		Swing level	Pre-emphasis
L	L	400mV diff p-p	0dB
	H	600mV diff p-p	
H	L	400mV diff p-p	6dB
	H	600mV diff p-p	3.5dB

### Power Down Function

Setting the PDN pin low places THCV219 in the power-down mode. Internal circuitry turns off and the TXP/N outputs turn to High level.

Table 4. Power Down function table

PDN	Description
L	Power Down
H	Normal Operation



### Field BET Operation

In order to help users to check validity of CML high-speed serial line, THCV219 has an operation mode in which they act as a bit error tester (BET). In this mode, THCV219 internally generates test pattern which is then serialized onto the CML high-speed line. THCV220 which is an example of Rx device also has BET function mode. THCV220 receives the data stream and checks bit errors.

This "Field BET" mode is activated by setting BET= H both on THCV219 and THCV220. The generated data pattern is then 8b/10b encoded, scrambled, and serialized onto the CML channel. As for THCV220, the internal test pattern check circuit gets enabled and reports result on a certain pin named BETOUT. The BETOUT pin goes LOW whenever bit errors occur, or it stays HIGH when there is no bit error. Please refer to Table 5.

Table 5. Field BET operation pin settings

THCV219	THCV220	Condition
BET	BET	
L	L	Normal Operation
H	H	Field BET Operation

Table 6. THCV220 Field BET result

BETOUT	Output
L	Bit error occurred
H	No error

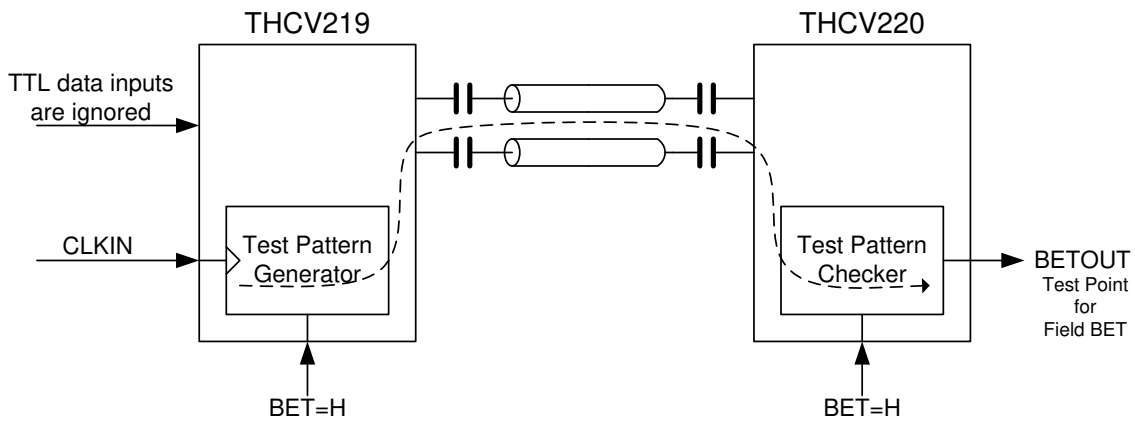

Figure 5. Field BET Configuration

**Absolute Maximum Ratings\***

Parameter	min.	typ.	max.	Unit
Supply Voltage(VCC,AVCC)	-0.3	-	+4.0	V
CMOS Input Voltage	-0.3	-	VCC+0.3	V
CML Transmitter Output Voltage	-0.3	-	CAPINA+0.3	V
Output Current	-30	-	30	mA
Storage Temperature	-55	-	+125	°C
Junction Temperature	-	-	+125	°C
Reflow Peak Temperature/Time	-	-	+260/10sec	°C

\* “Absolute Maximum Ratings” are those values beyond which the safety of the device can not be guaranteed. They are not meant to imply that the device should be operated at these limits. The tables of “Electrical Characteristics” specify conditions for device operation.

**Recommended Operating Conditions**

Parameter	min.	typ.	max.	Unit
Supply Voltage (VCC,AVCC)	2.3	2.5	2.7	V
	2.6	2.8	3.0	V
	3.0	3.3	3.6	V
CAPOUT and CAPINA Voltage	-	1.20	-	V
Operating Temperature	-40	-	85	°C

**Supply Current**

Over recommended operating supply and temperature ranges unless otherwise specified.

symbol	Parameter	conditions	min.	typ.	max.	Unit
ITCCW	Transmitter Supply Current	COL=L PRE=H	-	-	100	mA
ITCCS	Transmitter Power Down Supply Current	PDN=L All Inputs =Fixed LorH	-	1.2	10	mA

## Electrical Specifications

### CMOS DC Specifications

Over recommended operating supply and temperature ranges unless otherwise specified.

symbol	Parameter	conditions	min.	typ.	max.	Unit
I <sub>IH</sub>	Input Leak Current High		-10	-	+10	uA
I <sub>IL</sub>	Input Leak Current Low		-10	-	+10	uA

VCC=3.3±0.3V

symbol	Parameter	conditions	min.	typ.	max.	Unit
V <sub>IH</sub>	High Level Input Voltage	I <sub>3</sub>	2.0	-	VCC	V
		I <sub>3L</sub>	2.1	-	VCC	V
V <sub>IL</sub>	Low Level Input Voltage	I <sub>3</sub>	0	-	0.8	V
		I <sub>3L</sub>	0	-	0.7	V

VCC=2.8±0.2V

symbol	Parameter	conditions	min.	typ.	max.	Unit
V <sub>IH</sub>	High Level Input Voltage	I <sub>3</sub>	1.8	-	VCC	V
		I <sub>3L</sub>	1.9	-	VCC	V
V <sub>IL</sub>	Low Level Input Voltage	I <sub>3</sub>	0	-	0.7	V
		I <sub>3L</sub>	0	-	0.6	V

VCC=2.5±0.2V

symbol	Parameter	conditions	min.	typ.	max.	Unit
V <sub>IH</sub>	High Level Input Voltage	I <sub>3</sub>	1.7	-	VCC	V
		I <sub>3L</sub>	1.6	-	VCC	V
V <sub>IL</sub>	Low Level Input Voltage	I <sub>3</sub>	0	-	0.7	V
		I <sub>3L</sub>	0	-	0.5	V

### CML DC Specifications

Over recommended operating supply and temperature ranges unless otherwise specified.

symbol	Parameter	conditions	min.	typ.	max.	Unit
V <sub>TOD</sub>	CML Differential Mode Output Voltage	CMLDRV=L	133	200	267	mV
		CMLDRV=H	200	300	400	mV
PRE	CML Pre-emphasis Level	PRE=L	-	0	-	%
		PRE=H, CMLDRV=L	-	100	-	%
		PRE=H, CMLDRV=H	-	50	-	%
V <sub>TOC</sub>	CML Common Mode Output Voltage	PRE=L	1.2 - V <sub>TOD</sub>			V
		PRE=H, CMLDRV=L	1.2 - 2 * V <sub>TOD</sub>			V
		PRE=H, CMLDRV=H	1.2 - 1.5 * V <sub>TOD</sub>			V
I <sub>TOH</sub>	CML Output Leak Current High	PDN=L, TXP/N=1.2V	-	-	±30	uA
I <sub>TOS</sub>	CML Output Short Circuit Current	PDN=L, TXP/N=0V	-80	-	-	mA

### AC Specifications

Over recommended operating supply and temperature ranges unless otherwise specified.

symbol	Parameter	conditions	min.	typ.	max.	Unit
t <sub>TRF</sub>	CML Output Rise and Fall Time(20%-80%)		50	-	150	ps
t <sub>TCIP</sub>	CLKIN Period	COL=H, LFSEL=L	10	-	50	ns
		COL=H, LFSEL=H	25	-	100	ns
		COL=L, LFSEL=L	13.34	-	66.66	ns
		COL=L, LFSEL=H	33.34	-	133.33	ns
t <sub>TCH</sub>	CLK IN High Time		0.35t <sub>TCIP</sub>	0.5t <sub>TCIP</sub>	0.65t <sub>TCIP</sub>	ns
t <sub>TCL</sub>	CLK IN Low Time		0.35t <sub>TCIP</sub>	0.5t <sub>TCIP</sub>	0.65t <sub>TCIP</sub>	ns
t <sub>TSS</sub>	TTL Data Setup to CLK IN		2.0	-	-	ns
t <sub>TH</sub>	TTL Data Hold to CLK IN		0.6	-	-	ns
t <sub>TCO</sub>	Input Clock to Output Data Delay	COL=H	typ. - t <sub>TCIP</sub>	10.6t <sub>TCIP</sub> +1.7	typ. + t <sub>TCIP</sub>	ns
		COL=L	typ. - t <sub>TCIP</sub>	9.8t <sub>TCIP</sub> +1.7	typ. + t <sub>TCIP</sub>	ns
t <sub>TPD</sub>	Power On to PDN High Delay		0	-	-	ns
t <sub>TPLL0</sub>	PDN High to CML Output Delay		-	-	10	ms
t <sub>TPLL1</sub>	PDN Low to CML Output High Fix Delay		-	-	20	ns
t <sub>TNP0</sub>	LOCKN High to Training Pattern Output Delay		-	-	10	ms
t <sub>TNP1</sub>	LOCKN Low to Data Pattern Output Delay		-	-	10	ms

## AC Timing Diagrams and Test Circuits

### CMOS/TTL Input Switching Characteristics

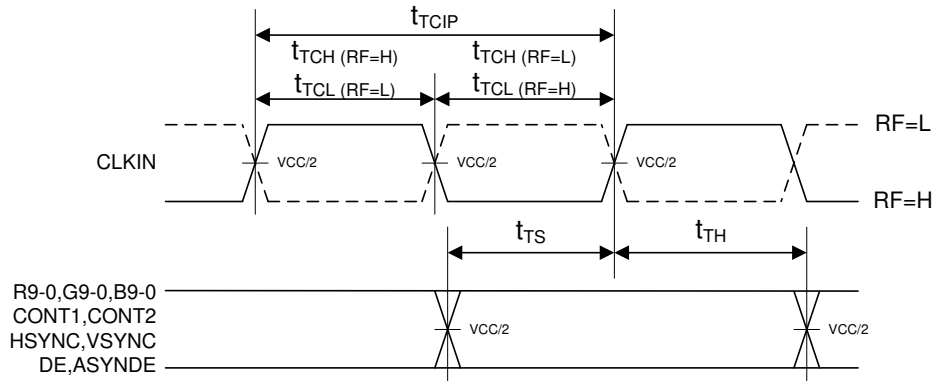

Figure 6. CMOS/TTL Input Switching Timing Diagrams

### CML Output Switching Characteristics

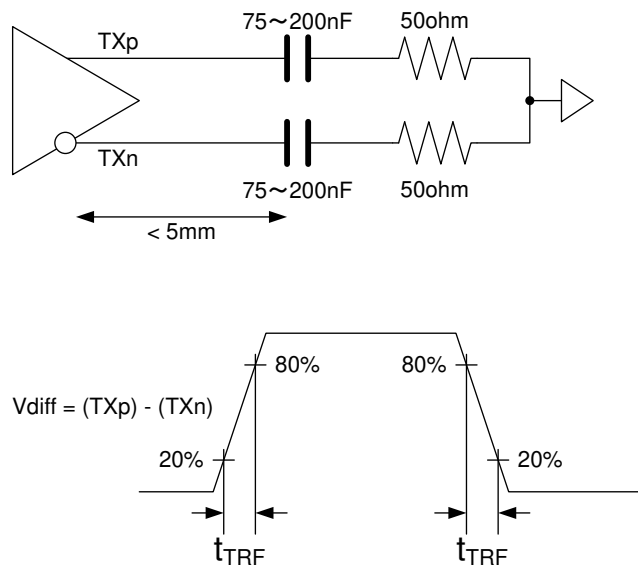

Figure 7. CML buffer Switching Timing Diagrams and Test Circuit

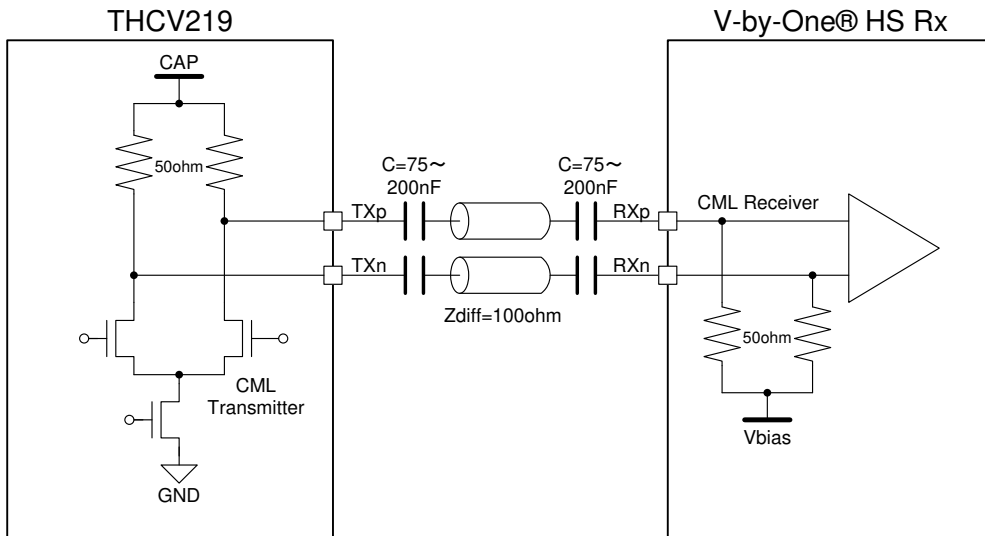

Figure 8. CML buffer scheme

Latency Characteristics

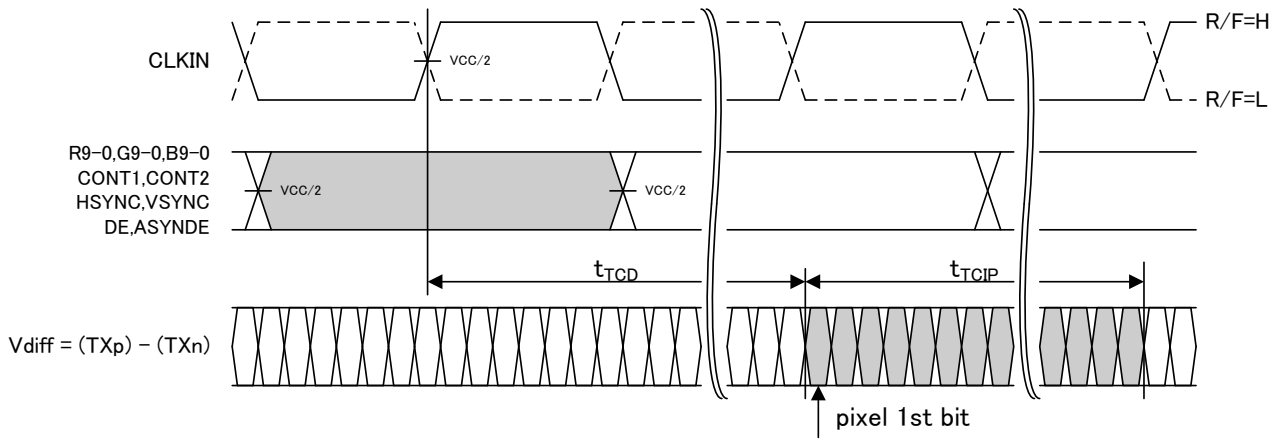

Figure 9. THCV219 Latency

Data output Sequence

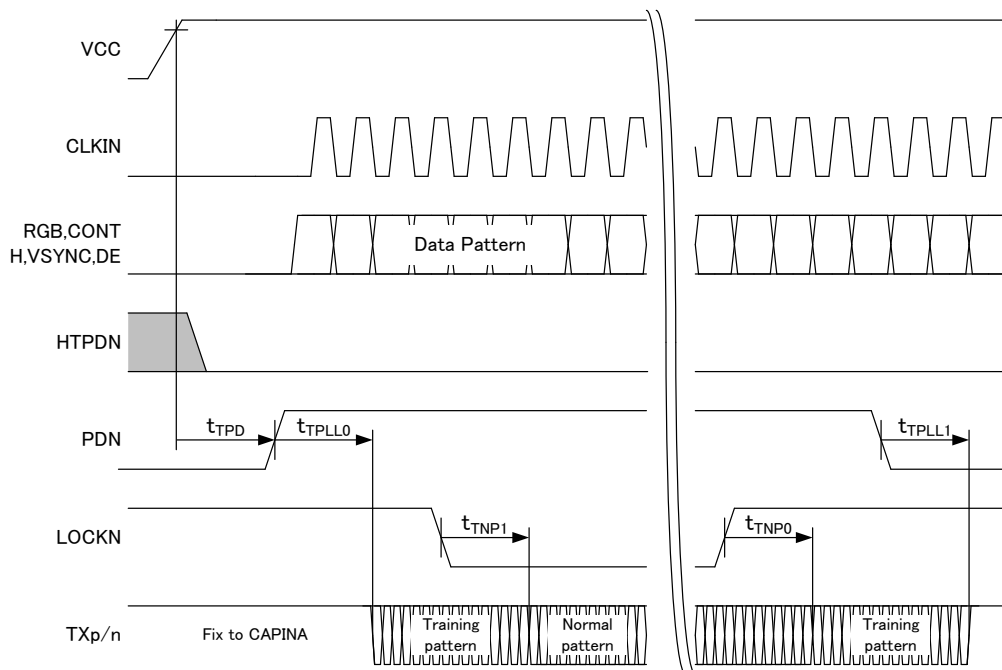

Figure 10. THCV219 Sequence

## Data Mapping

Table 7. CMOS/TTL Input Data Mapping

Data Signals		Transmitter Input Pin Name		Symbol defined by V-by-One® HS
10bit (30bpp)	8bit (24bpp)	10bit (30bpp)	8bit (24bpp)	
R0 *1	-	R0	-	D30
R1 *1	-	R1	-	D31
R2	R0	R2	R2	D0
R3	R1	R3	R3	D1
R4	R2	R4	R4	D2
R5	R3	R5	R5	D3
R6	R4	R6	R6	D4
R7	R5	R7	R7	D5
R8	R6	R8	R8	D6
R9	R7	R9	R9	D7
G0 *1	-	G0	-	D28
G1 *1	-	G1	-	D29
G2	G0	G2	G2	D8
G3	G1	G3	G3	D9
G4	G2	G4	G4	D10
G5	G3	G5	G5	D11
G6	G4	G6	G6	D12
G7	G5	G7	G7	D13
G8	G6	G8	G8	D14
G9	G7	G9	G9	D15
B0 *1	-	B0	-	D26
B1 *1	-	B1	-	D27
B2 *1	B0 *1	B2	B2	D16
B3 *1	B1 *1	B3	B3	D17
B4 *1	B2 *1	B4	B4	D18
B5 *1	B3 *1	B5	B5	D19
B6 *1	B4 *1	B6	B6	D20
B7 *1	B5 *1	B7	B7	D21
B8 *1	B6 *1	B8	B8	D22
B9 *1	B7 *1	B9	B9	D23
CONT1 *1	-	CONT1	-	D25
CONT2 *1	-	CONT2	-	D24
HSYNC	HSYNC	HSYNC	HSYNC	HSYNC
VSYNC	VSYNC	VSYNC	VSYNC	VSYNC
DE	DE	DE	DE	DE

\*1 CTL bits, which are carried during DE=Low except the 1<sup>st</sup> and the last pixel.

Package

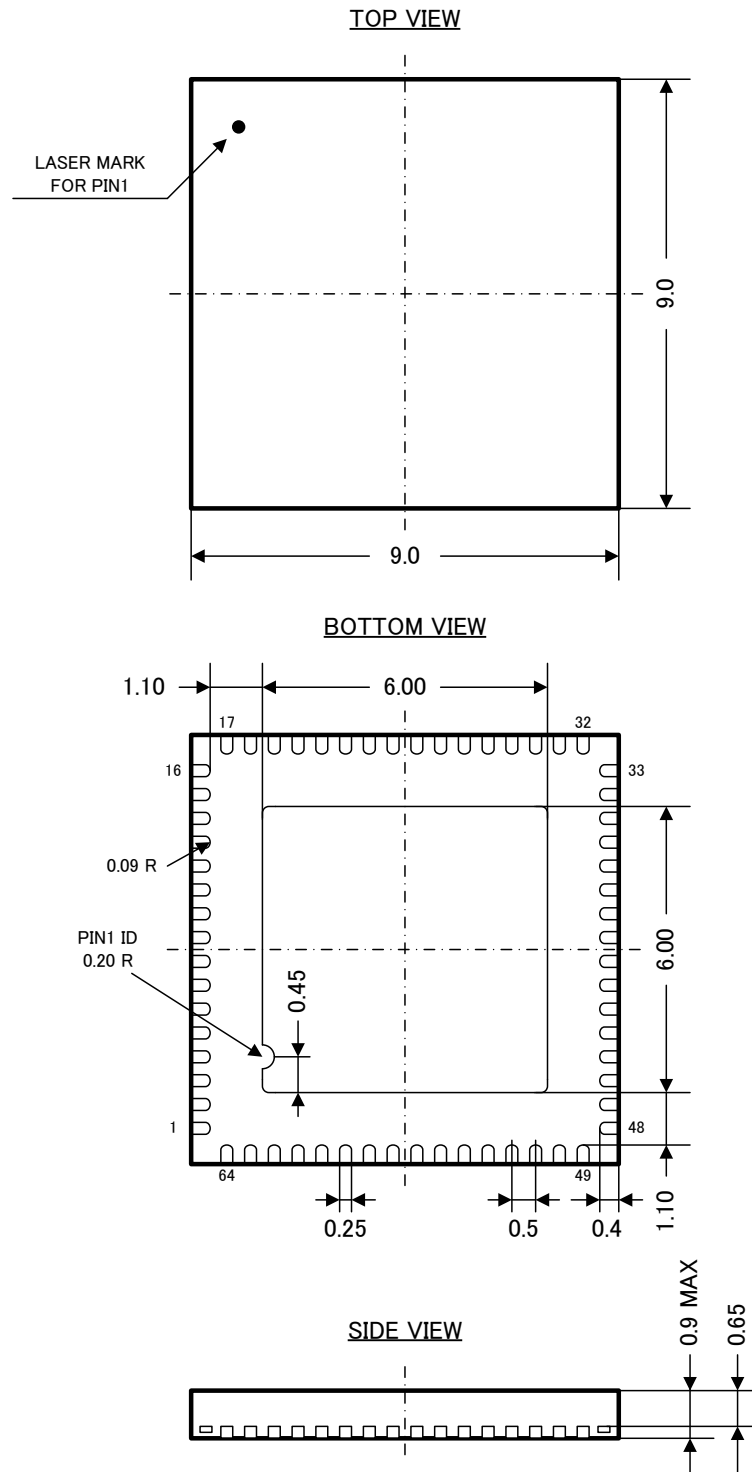



## Notices and Requests

1. The product specifications described in this material are subject to change without prior notice.
2. The circuit diagrams described in this material are examples of the application which may not always apply to the customer's design. We are not responsible for possible errors and omissions in this material. Please note if errors or omissions should be found in this material, we may not be able to correct them immediately.
3. This material contains our copyright, know-how or other proprietary. Copying or disclosing to third parties the contents of this material without our prior permission is prohibited.
4. Note that if infringement of any third party's industrial ownership should occur by using this product, we will be exempted from the responsibility unless it directly relates to the production process or functions of the product.
5. Product Application
  - 5.1 Application of this product is intended for and limited to the following applications: audio-video device, office automation device, communication device, consumer electronics, smartphone, feature phone, and amusement machine device. This product must not be used for applications that require extremely high-reliability/safety such as aerospace device, traffic device, transportation device, nuclear power control device, combustion chamber device, medical device related to critical care, or any kind of safety device.
  - 5.2 This product is not intended to be used as an automotive part, unless the product is specified as a product conforming to the demands and specifications of ISO/TS16949 ("the Specified Product") in this data sheet. THine Electronics, Inc. ("THine") accepts no liability whatsoever for any product other than the Specified Product for it not conforming to the aforementioned demands and specifications.
  - 5.3 THine accepts liability for demands and specifications of the Specified Product only to the extent that the user and THine have been previously and explicitly agreed to each other.
6. Despite our utmost efforts to improve the quality and reliability of the product, faults will occur with a certain small probability, which is inevitable to a semi-conductor product. Therefore, you are encouraged to have sufficiently redundant or error preventive design applied to the use of the product so as not to have our product cause any social or public damage.
7. Please note that this product is not designed to be radiation-proof.
8. Testing and other quality control techniques are used to this product to the extent THine deems necessary to support warranty for performance of this product. Except where mandated by applicable law or deemed necessary by THine based on the user's request, testing of all functions and performance of the product is not necessarily performed.
9. Customers are asked, if required, to judge by themselves if this product falls under the category of strategic goods under the Foreign Exchange and Foreign Trade Control Law.
10. The product or peripheral parts may be damaged by a surge in voltage over the absolute maximum ratings or malfunction, if pins of the product are shorted by such as foreign substance. The damages may cause a smoking and ignition. Therefore, you are encouraged to implement safety measures by adding protection devices, such as fuses.

***THine Electronics, Inc.***

<https://www.thine.co.jp>