

Instruction Manual

HCR - Home Care Robot

安装说明书

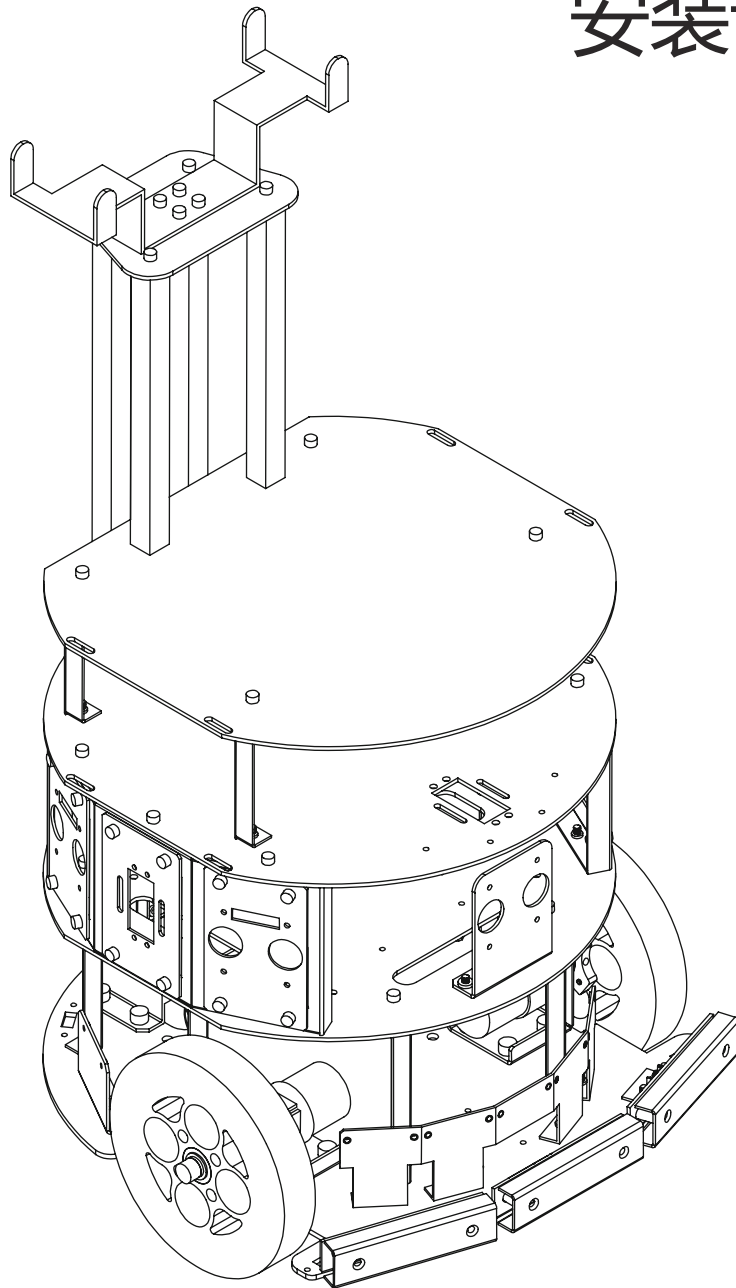

在使用HCR - Home Care Robot之前，请仔细阅读此说明书。
Read the manual carefully before using HCR - Home Care Robot.

Ver 1.1



电话 (Tel) : 86-021-61620183

网站 : www.DFRobot.com.cn

服务支持 (Service) : Techsupport@dfrobot.com

Website : www.DFRobot.com





© 本说明书最终解释权归DFRobot所有

DFRobot has the final authority of interpretation on this manual.



目录 Contents

电机装配.....	1
Motor Assembly	
万向轮装配.....	2
Caster Assembly	
底层装配.....	3-7
Bottom Assembly	
中层侧板装配.....	8
The Second Level Side Assembly	
中层装配.....	9
The Second Level Assembly	
上层装配.....	10
The Third Level Assembly	
Kinect支架装配.....	11
Kinect Level Assembly	
整机组装.....	12
Final Platform Assembly	
零部件清单.....	13
Parts List	

电机装配 (a) Motor Assembly (a)

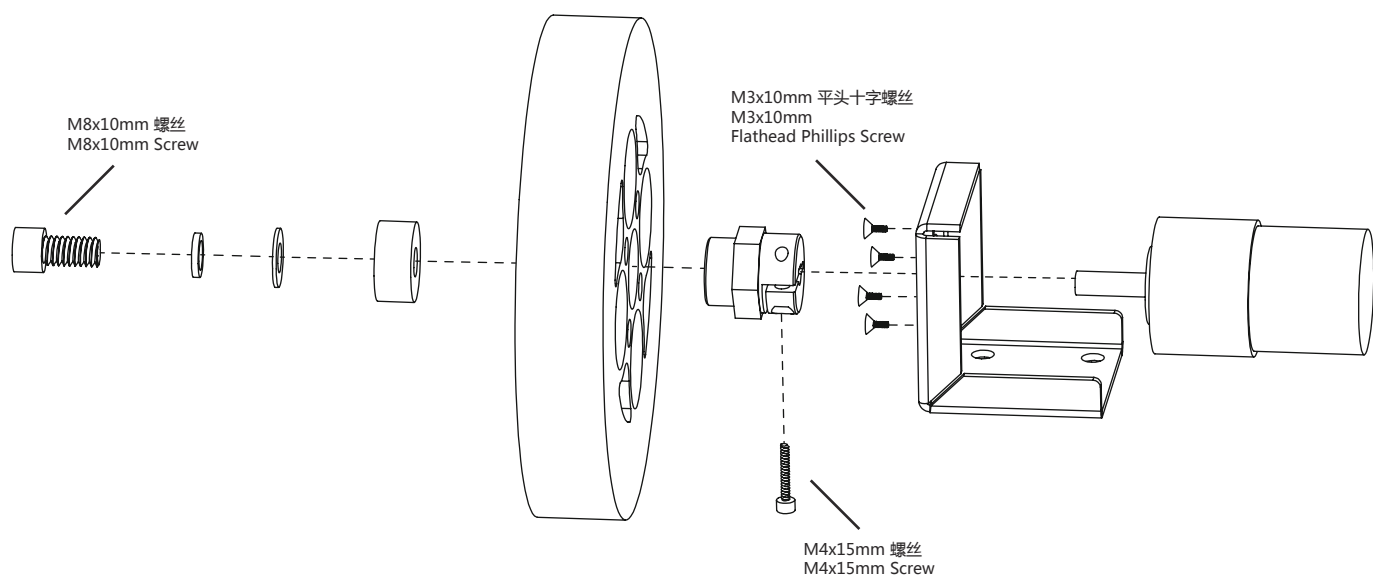
 <p>M4x15mm 螺丝 M4x15mm Screw</p>	 <p>M8x10mm 螺丝 M8x10mm Screw</p>	 <p>M8 弹片 M8 Stainless Steel Spring Washer</p>	 <p>M8 垫片 M8 Washer</p>
---	---	---	--

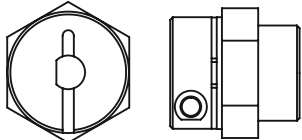
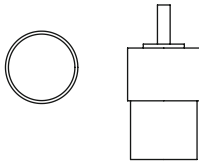
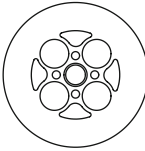
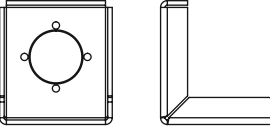
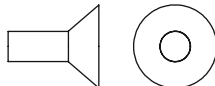

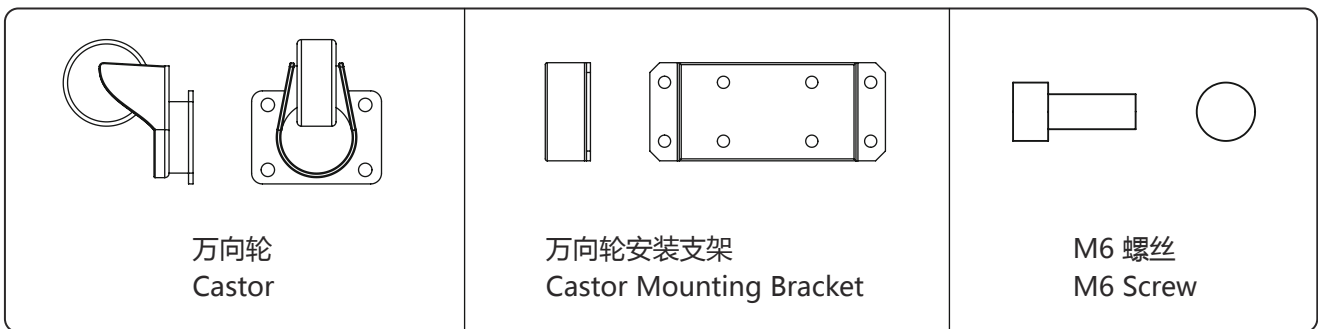
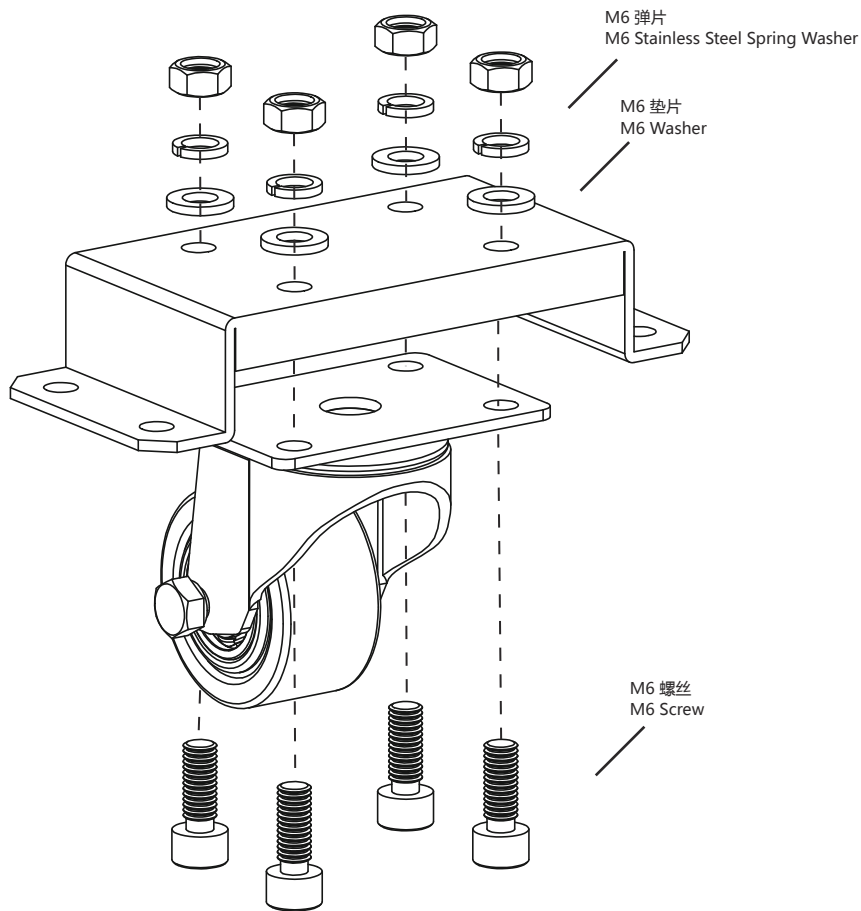

 <p>联轴器 Coupler</p>	 <p>电机 Motor</p>	 <p>轮子 Wheel</p>
 <p>电机固定板 Motors mounting bracket</p>	 <p>M3x10mm 平头十字螺丝 M3x10mm Flathead Phillips Screw</p>	 <p>挡圈 Retaining Ring</p>

万向轮装配 Caster Assembly

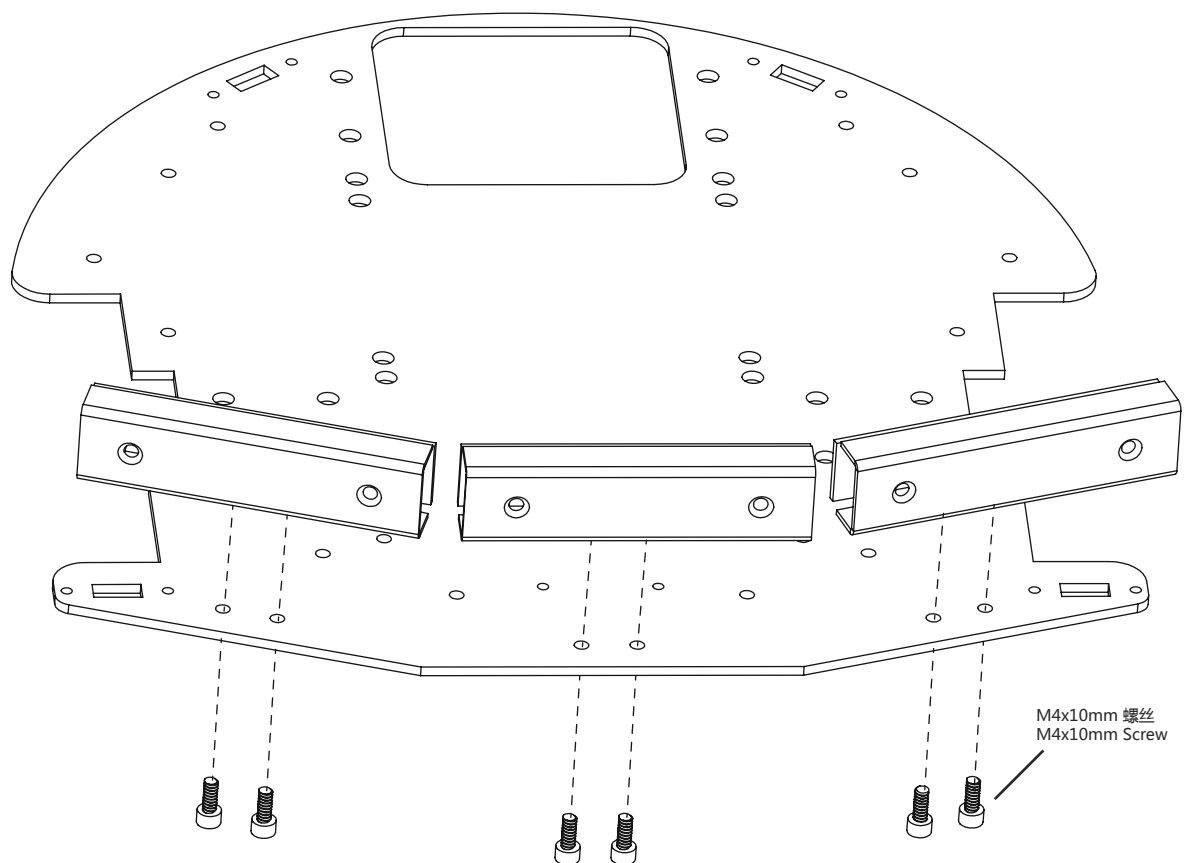

底层装配 (a) Bottom Assembly (a)

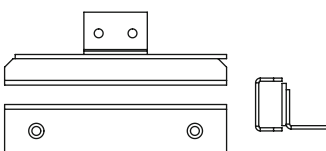
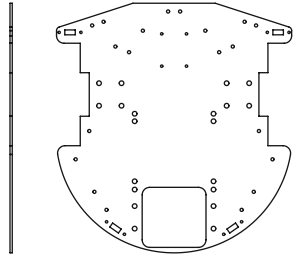

 <p>碰撞传感器 Bumper</p>	 <p>底板 bottom level</p>	 <p>M4x10mm 螺丝 M4x10mm Screw</p>
---	--	---

底层装配 (b) Bottom Assembly (b)

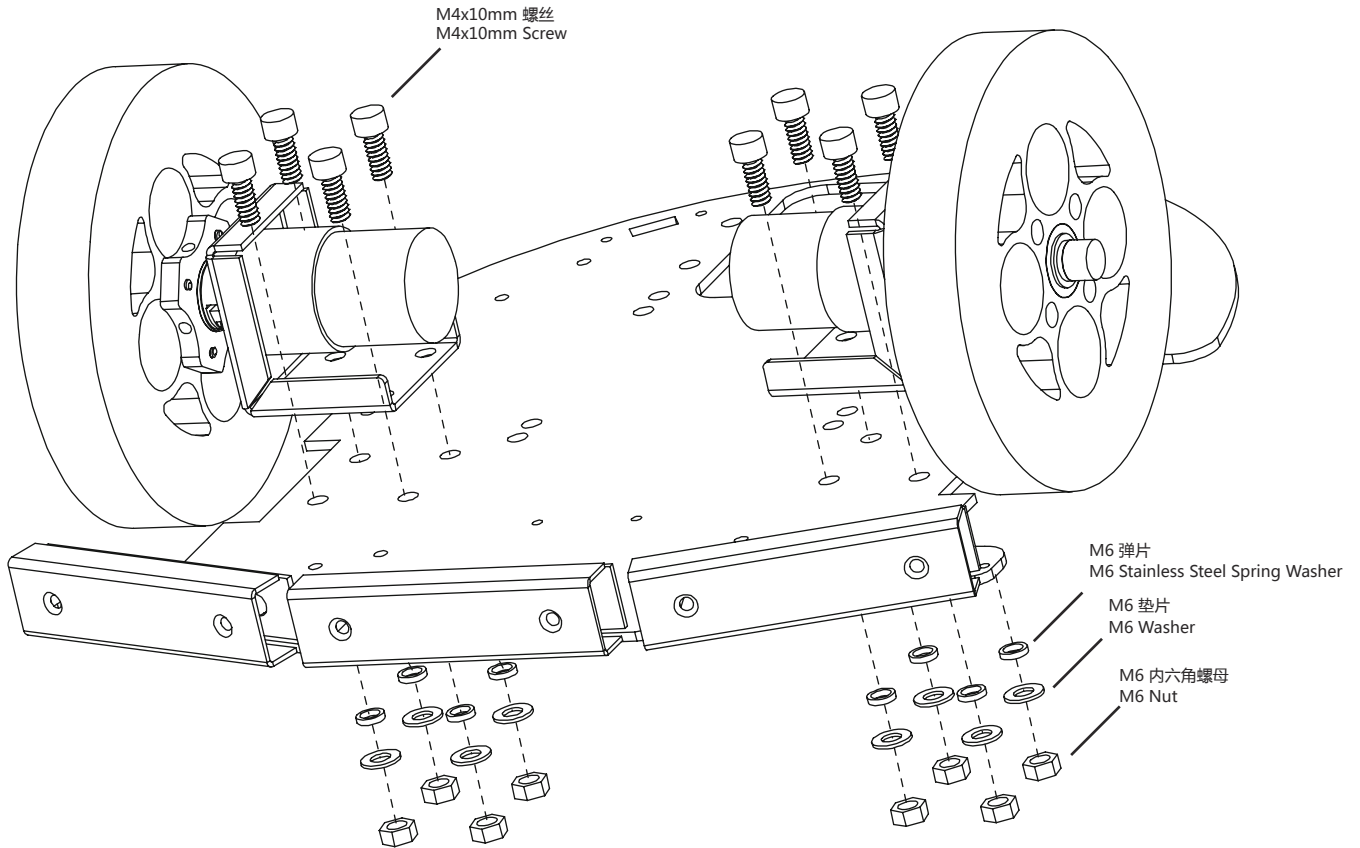

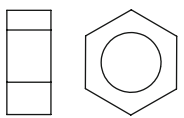
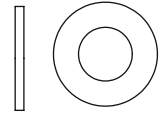
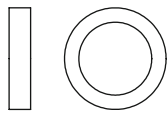
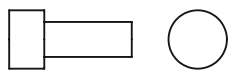
 <p>M6 内六角螺母 M6 Nut</p>	 <p>M6 垫片 M6 Washer</p>	 <p>M6 弹片 M6 Stainless Steel Spring Washer</p>	 <p>M6 螺丝 M6 Screw</p>
--	--	---	---

底层装配 (c) Bottom Assembly (c)

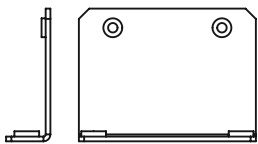
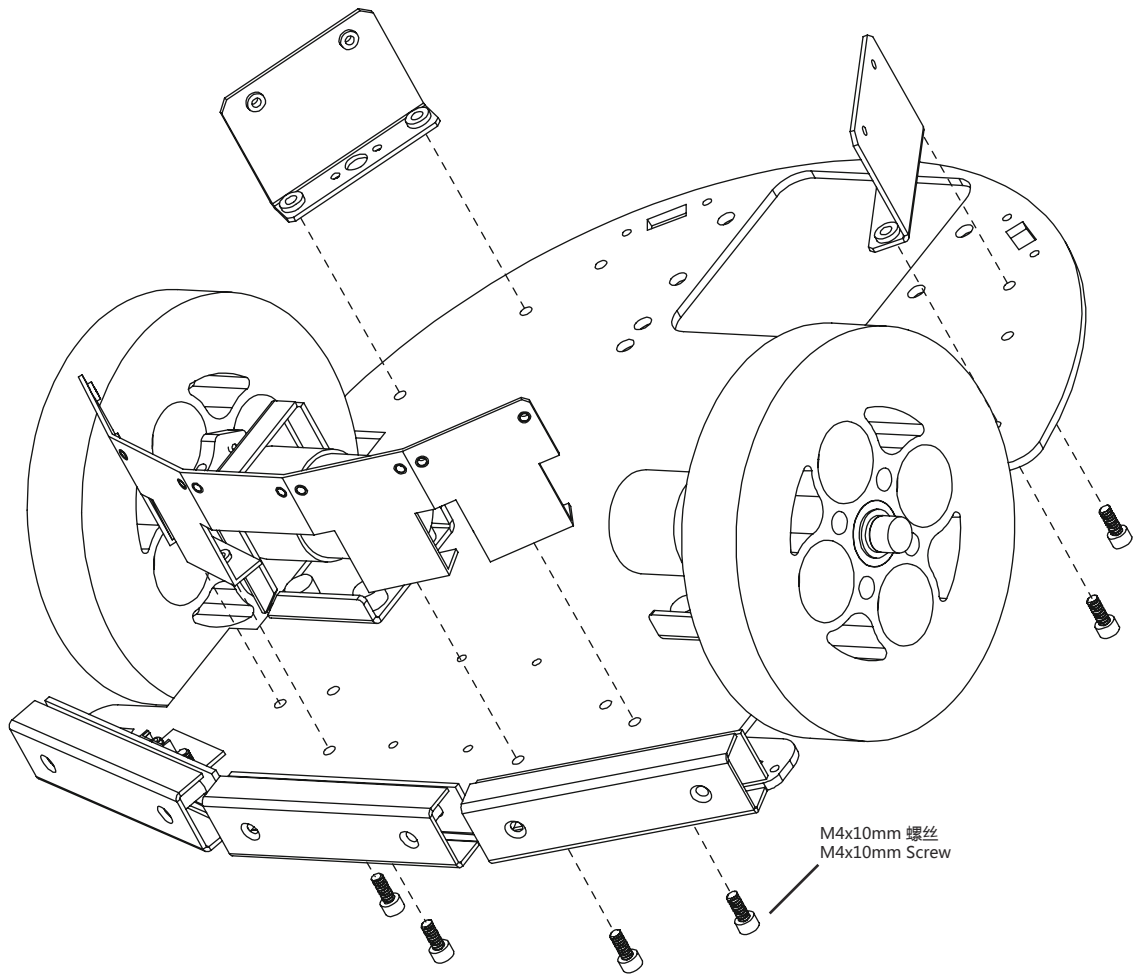

后红外安装支架
rear IR mounting bracket

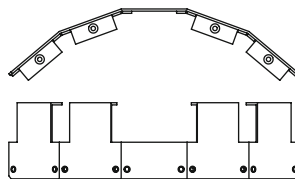

前红外安装支架
front IR mounting bracket

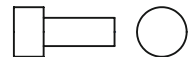

M4x10mm 螺丝
M4x10mm Screw

底层装配 (d) Bottom Assembly (d)

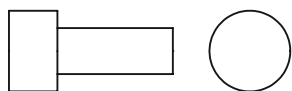
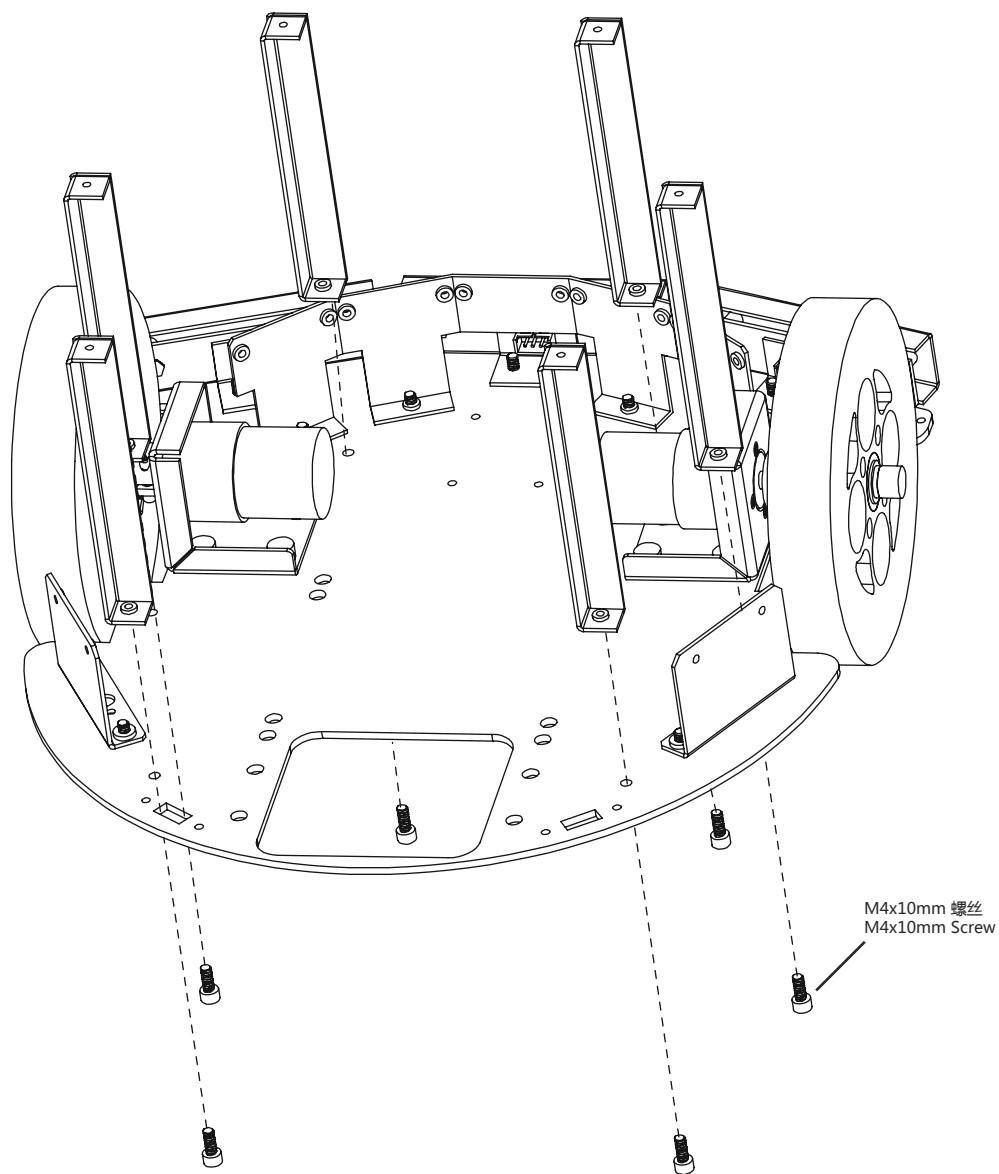

M4x10mm 螺丝
M4x10mm Screw



立柱 12cm
Supporting Pillars

底层装配 (e) Bottom Assembly (e)

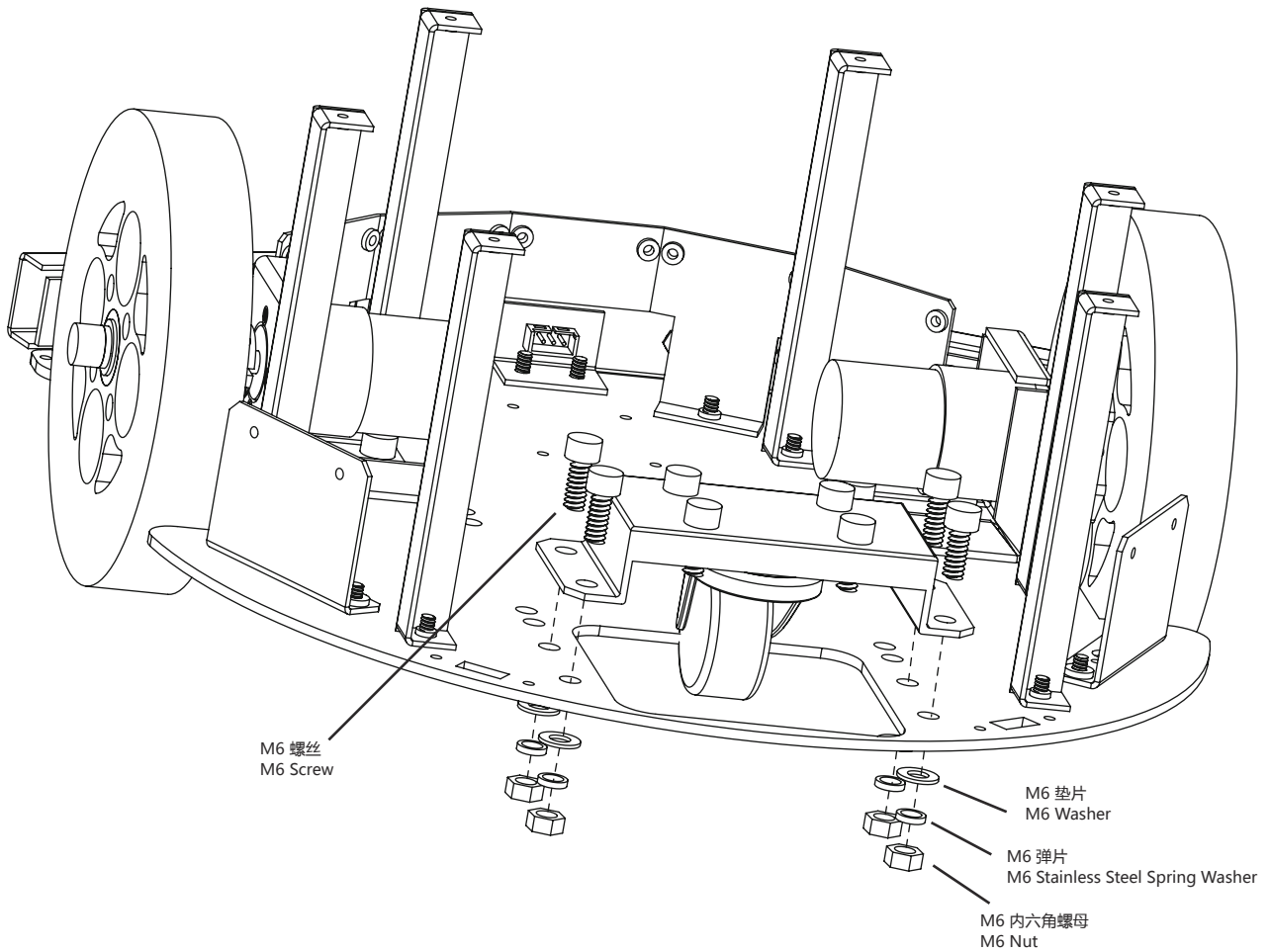

<p>M6 内六角螺母 M6 Nut</p>	<p>M6 垫片 M6 Washer</p>	<p>M6 弹片 M6 Stainless Steel Spring Washer</p>	<p>M6 螺丝 M6 Screw</p>

中层侧板装配 The Second Level Side Assembly

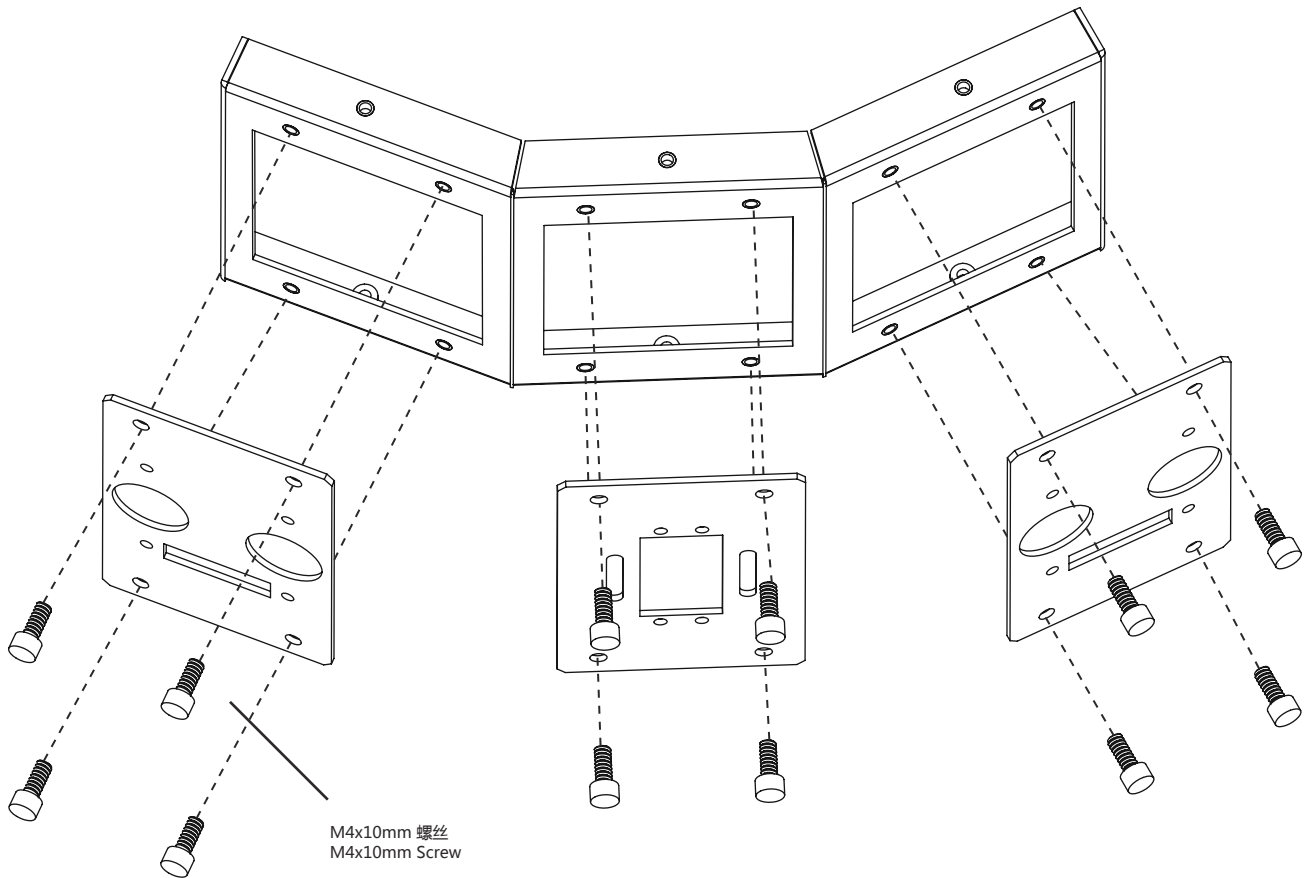

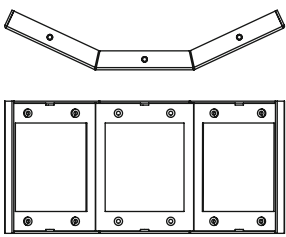
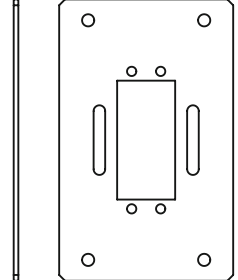
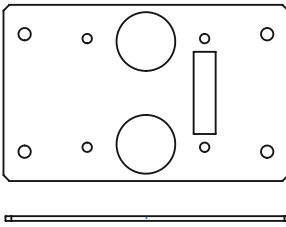
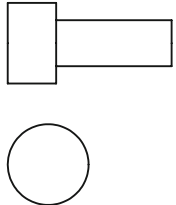
 <p>侧板支架 The Second Level Side Bracket</p>	 <p>舵机扩展板 Servo Pan/Tilt Bracket</p>	 <p>超声波安装板 URM04 Ultrasonic Mounting Bracket I</p>	 <p>M4x10mm 螺丝 M4x10mm Screw</p>
---	---	--	---

中层装配 The Second Level Assembly

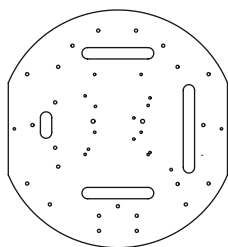
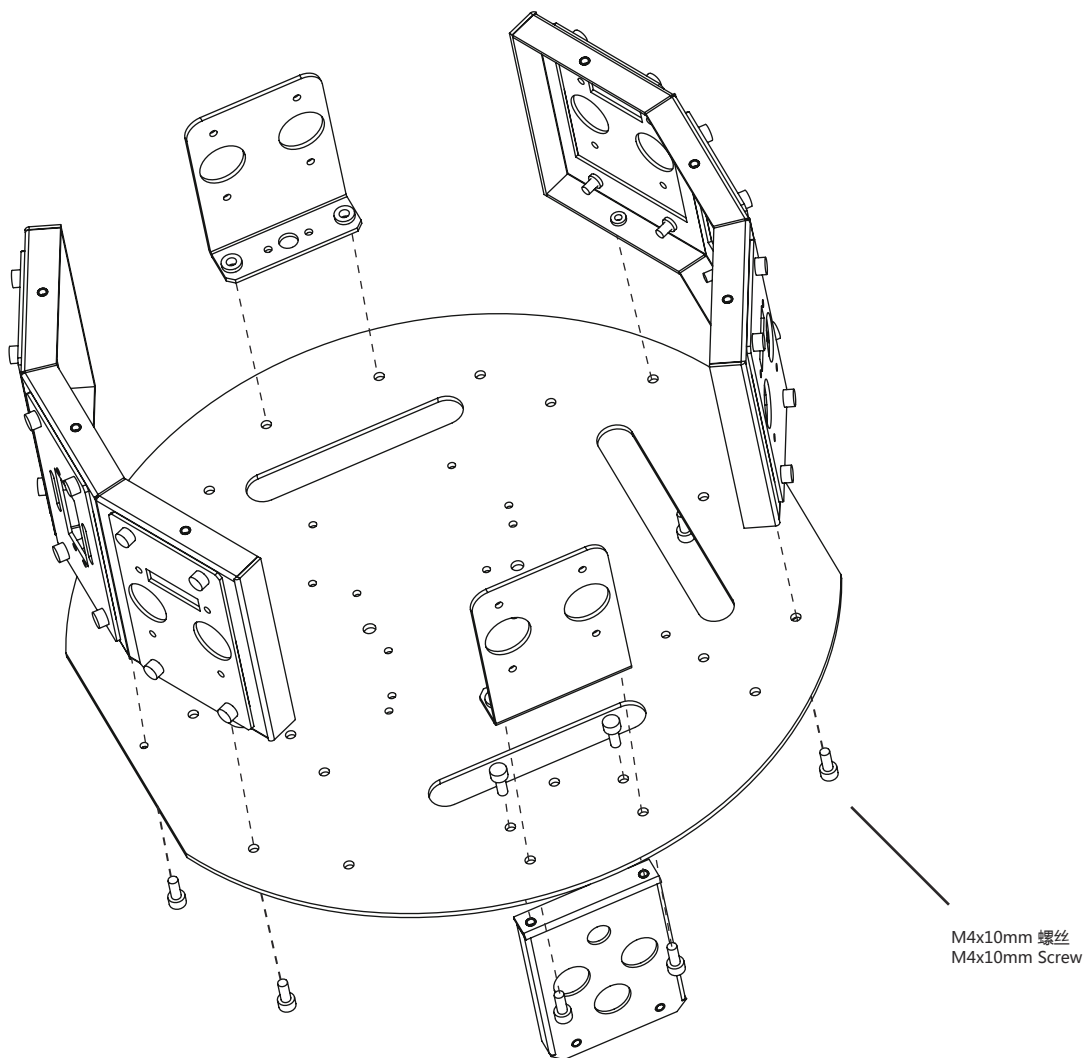

中层板
The Second Level

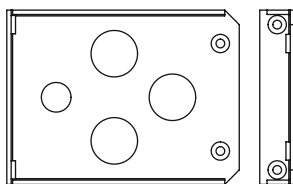

开关安装板
Switch mounting bracket

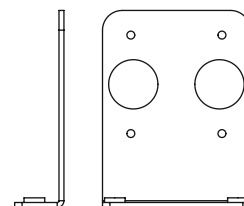

超声波安装板
URM04 Ultrasonic mounting bracket I

kinect支架装配 Kinect Level Assembly

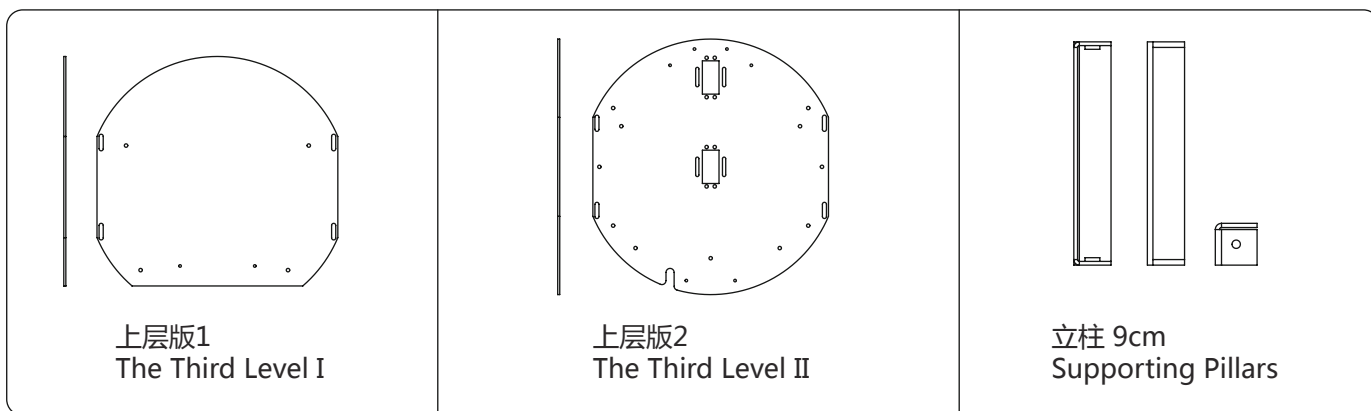
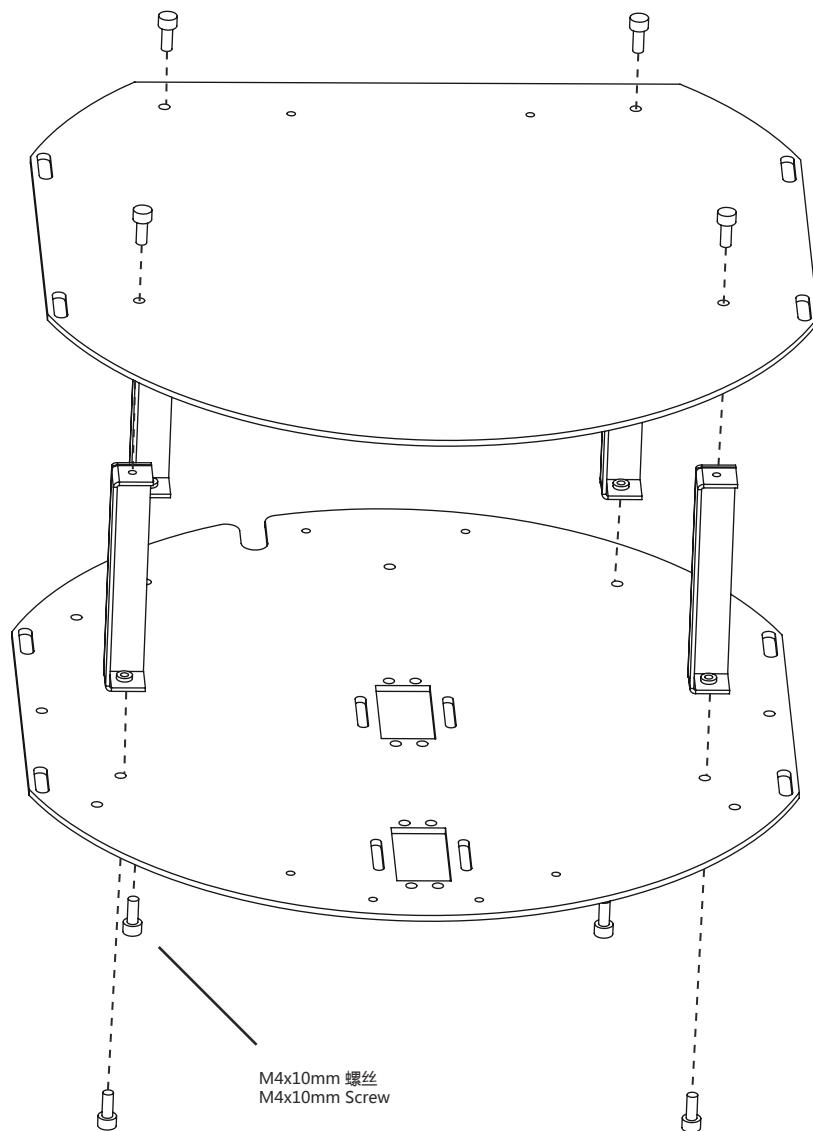

Kinect支架装配 Kinect Level Assembly

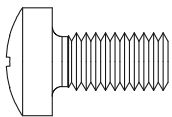
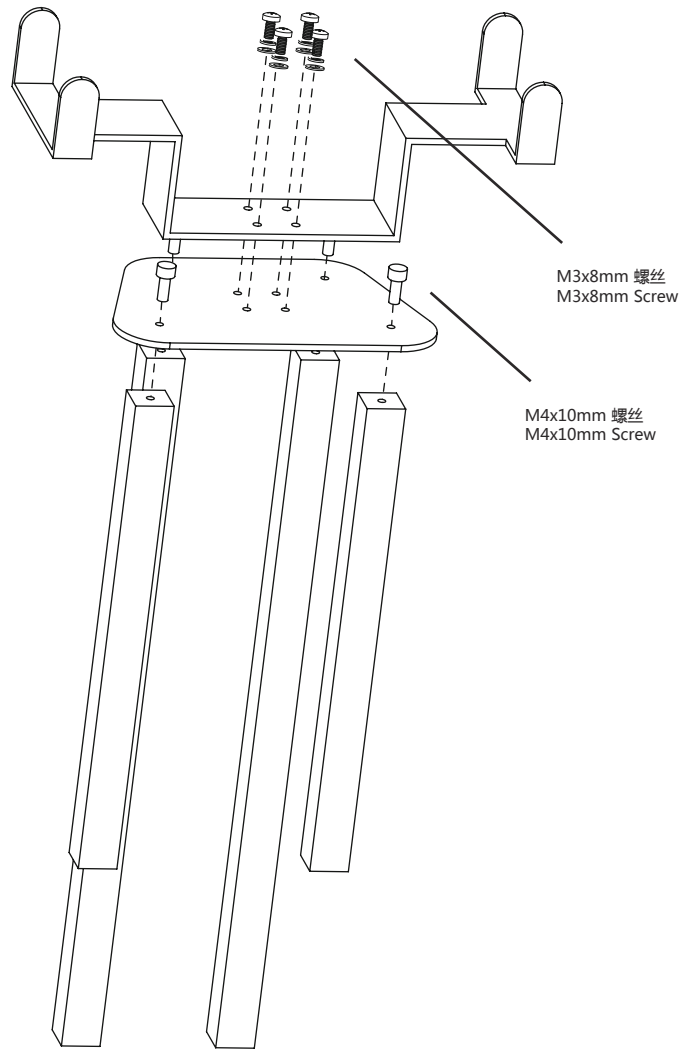

M3x8mm 螺丝
M3x8mm Screw

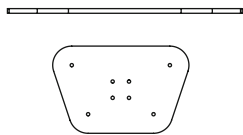

转台支撑
Supporting Pillars

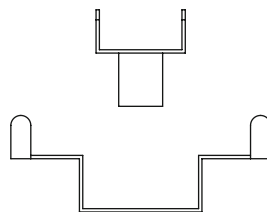

XBox 支架
XBox Mounting Bracket Bottom

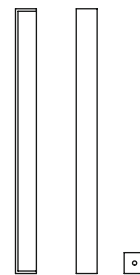

立柱 19cm
Supporting Pillars



立柱 28.25cm
Supporting Pillars

整机组装 Final Platform Assembly

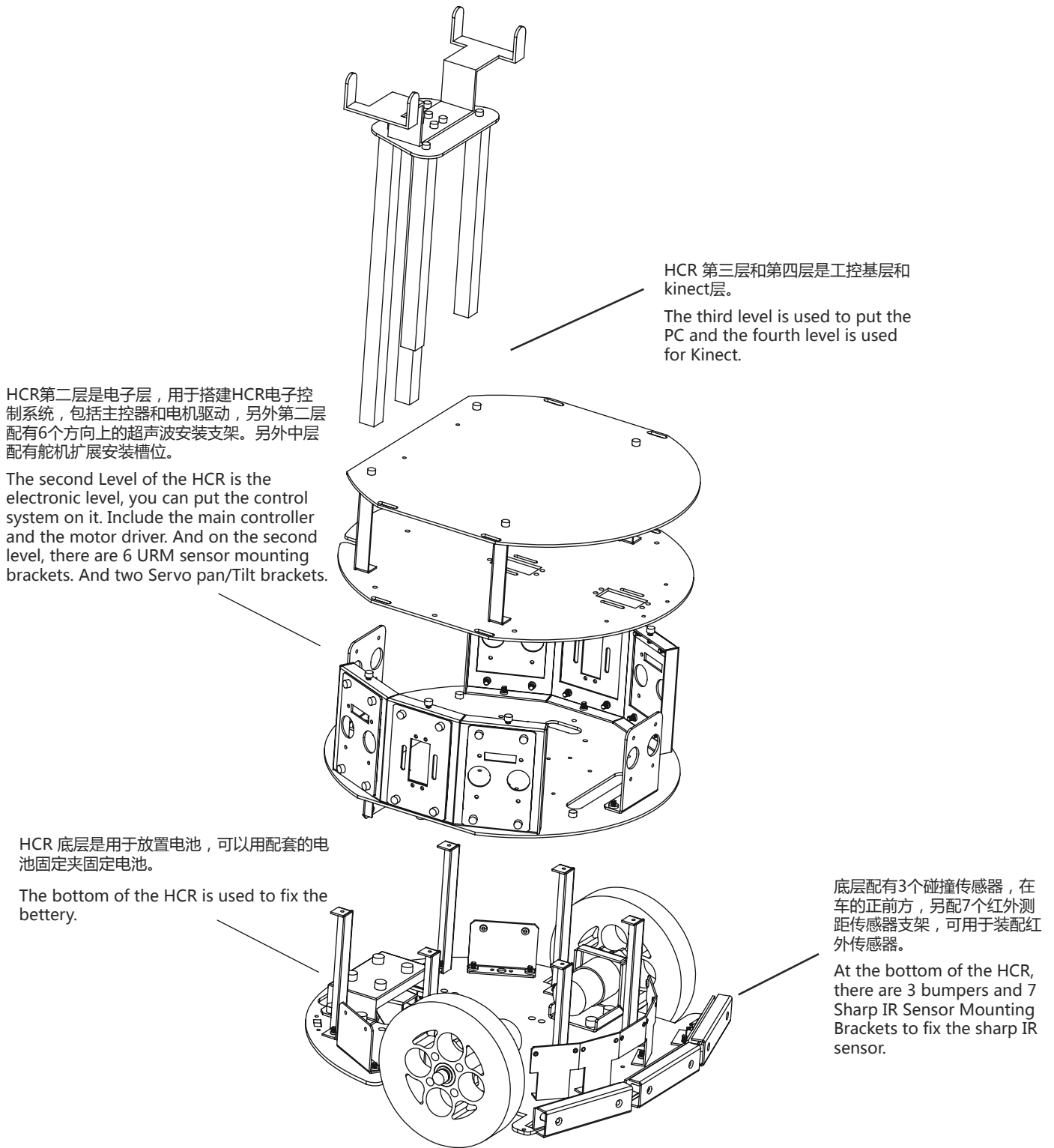

零部件清单 Parts List

零件名称	Parts	数量
底板	Bottom	1
中层板	The Second Chassis	1
第三层板	The IPC Level Up Chassis	1
工控机上层板	The IPC Bottom Chassis	1
前红外安装支架	Front IR Mounting Bracket	1
后红外安装支架	Rear IR Mounting Bracket	2
开关安装支架	Power Switch Mounting Bracket	1
超声波支架	URM04 Ultrasonic Mounting Bracket I	2
舵机扩展安装板	Servo Pan/Tilt Bracket	2
中层侧板	The Second Level Side Bracket	2
URM4超声波扩展支架	URM4 Ultrasonic Mounting Bracket II	4
底板立柱 12CM	Supporting Pillars	6
工控机层立柱 9CM	Supporting Pillars	4
XBOX立柱 19CM	Supporting Pillars	2
XBOX立柱 28.25cm	Supporting Pillars	2
转台支撑	XBOX Mounting Bracket Bottom	1
Xbox 支架	XBOX Mounting Bracket	1
轮子	Wheels	2
联轴器	Coupler	2
万向轮	Castor Wheel	1
万向轮安装架	Castor Mounting Bracket	1
直流电机	DC Motors with Encoders and Cables	2
马达安装支架	Motors Mounting Bracket	2
碰撞传感器	Bumper Sensor	3
电池固定片	Battery Mounting Plate	2
M4*10内六角不锈钢安装螺丝	M4*10 Screw	80
M6*15内六角不锈钢安装螺丝	M6*15 Screw	18
铜柱螺丝包	Coin Screws	1
内6角扳手	Inner Hex Wrench	1
两头开口扳手	Two Open-end Wrench	1

家庭监护机器人基础电子配件 Home Care Robot Base electronic Parts list

- 主控器 : Arduino Mega / Main control: Arduino Mega
- 电机控制 : Arduino Nano / Motor control : Arduino Nano
- 电机驱动 : DC Motor Driver 2×15A / Motor Driver : DC Motor Driver 2×15A

家庭监护机器人进阶电子配件 Home Care Robot Advance electronic Parts list

- 主控器 : Arduino Mega / Main control: Arduino Mega
- 电机控制 : Arduino Nano / Motor control : Arduino Nano
- 电机驱动 : DC Motor Driver 2×15A / Motor Driver : DC Motor Driver 2×15A
- 红外测距传感器 / IR Sensor
- 超声波传感器 / URM Sensor

家庭监护机器人高级电子配件 Home Care Robot Senior electronic Part list

- 主控器 : Arduino Mega / Main control: Arduino Mega
- 电机控制 : Arduino Nano / Motor control : Arduino Nano
- 电机驱动 : DC Motor Driver 2×15A / Motor Driver : DC Motor Driver 2×15A
- 红外测距传感器 / IR Sensor
- 超声波传感器 / URM Sensor
- Xbee通讯模块 / XBee 1mW Wire Antenna
- GamePad V2.0 / GamePad V2.0
- DF-BluetoothV3蓝牙串口模块 / DFRobot Bluetooth V3