

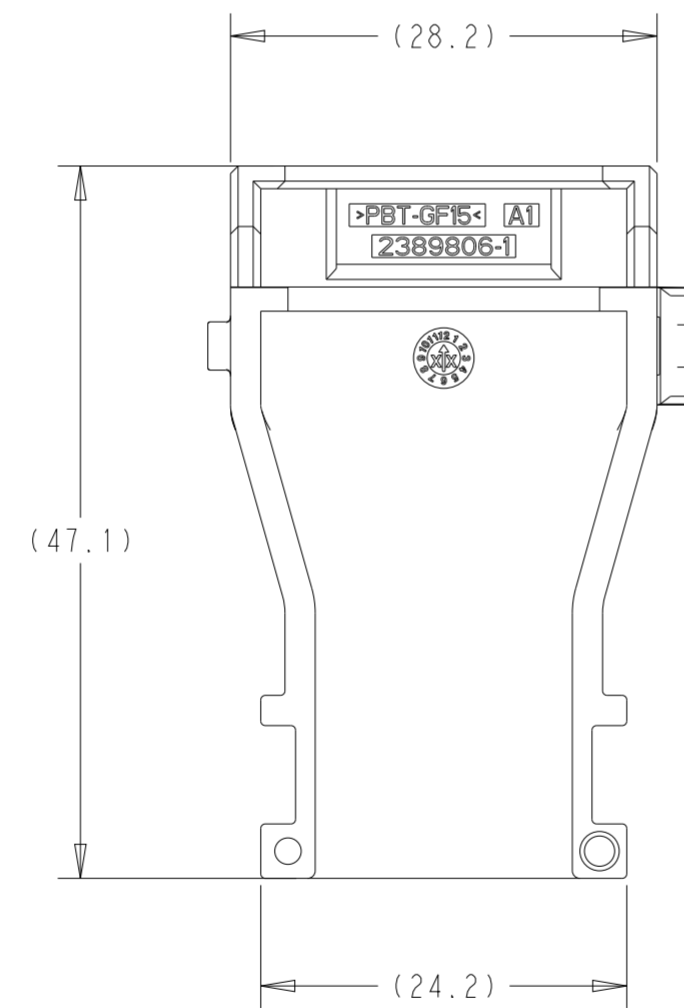

REVISIONS					
P	LTR	DESCRIPTION	DATE	DWN	APVD
A		INITIAL RELEASE PER ECN-22-151822	02MAY2022	FC	DK

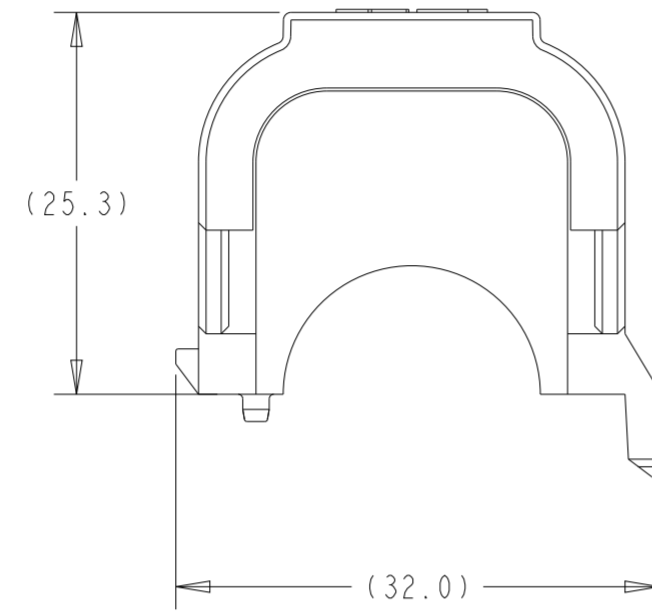

- 1 MATERIAL: PBT, 15% GLASS FILLED, COLOR: BLACK
- 2. USED WITH 23 POSITION AMPSEAL PLUG ASSEMBLY 770680
- 3. TWO PIECES REQUIRED PER ASSEMBLY
- 4. A WIRE TIE IS RECOMMENDED AROUND THE WIRE EXIT END OF THE BACKSHELL TO AID IN SECURING THE TWO HALVES TOGETHER

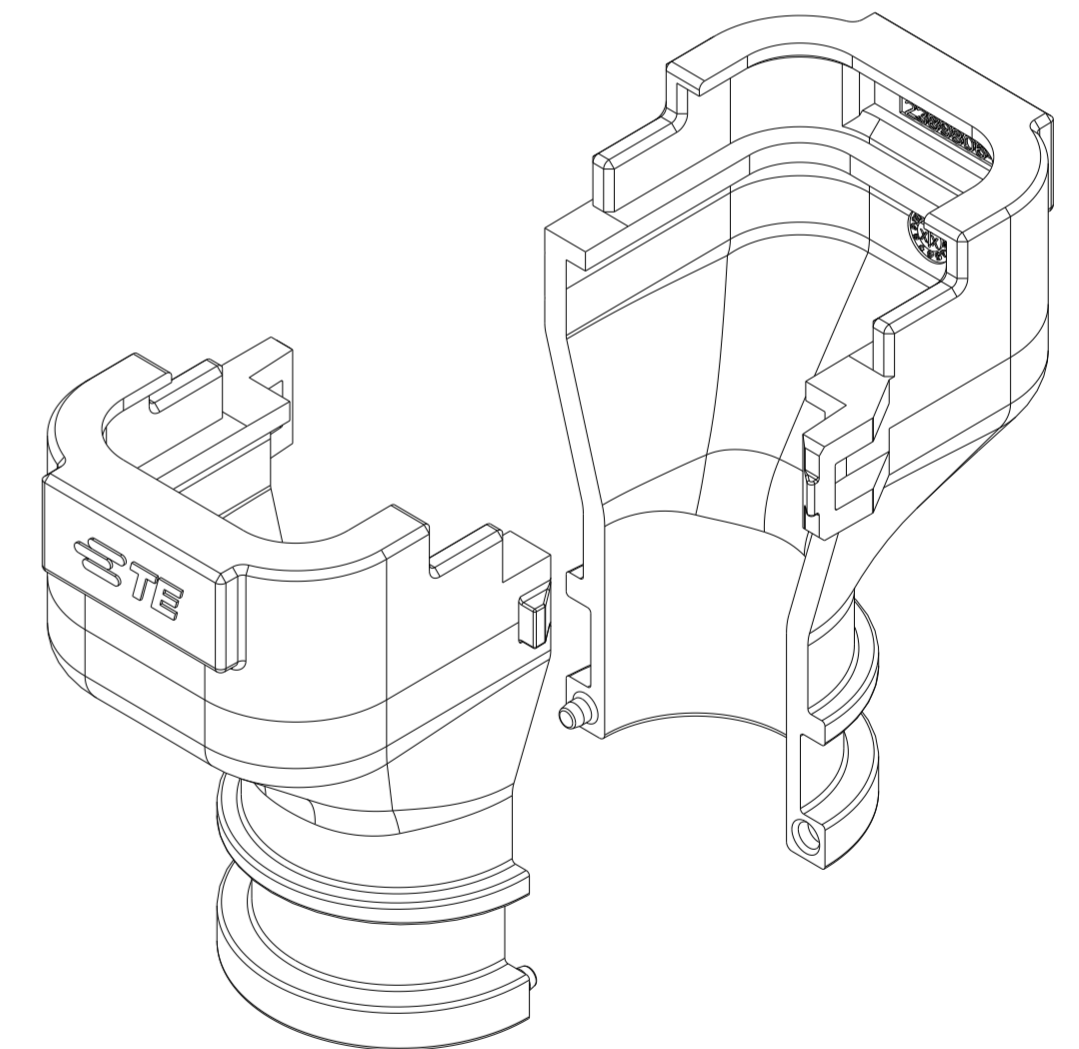

2389806-1
PART NO

THIS DRAWING IS A CONTROLLED DOCUMENT.		DWN F COLTA 02MAY2022	 TE Connectivity		
		CHK D KELLER 02MAY2022			
DIMENSIONS: mm		APVD C BHATT 02MAY2022	NAME WIRE RELIEF 23 POSITION, AMPSEAL		
TOLERANCES UNLESS OTHERWISE SPECIFIED: 0 PLC ± 1 PLC ± 2 PLC ± 3 PLC ± 4 PLC ± ANGLES ± FINISH -		PRODUCT SPEC 108-160593	RESTRICTED TO -		
MATERIAL 1		APPLICATION SPEC 114-16016	SIZE A2	CAGE CODE -	DRAWING NO C-2389806
		WEIGHT 6.9g	SCALE 2:1	SHEET 1 OF 1	REV A
		CUSTOMER DRAWING			