

KVW Supercapacitors

Coin cells



Description

Eaton supercapacitors are high reliability, high power, ultra-high capacitance energy storage devices utilizing electric double layer capacitor (EDLC) construction combined with proprietary materials and processes. This combination of advanced technologies allows Eaton to offer a wide variety of capacitor solutions tailored to applications for backup power, pulse power and hybrid power systems. They can be applied as the sole energy storage or in combination with batteries to optimize cost, life time and run time. System requirements can range from a few microwatts to megawatts. All products feature low ESR for high power density with environmentally friendly materials for a green power solution. Eaton supercapacitors are maintenance-free with design lifetimes up to 20 years* and operating temperatures down to -40 °C and up to +85 °C.

Features

- High specific capacitance
- Low leakage current
- Long cycle life
- Eco-friendly
- Broad operating temperature range, -40 °C to +85 °C

Applications

- Electric utility meters
- Computers and peripherals
- Network switches and routers
- Consumer goods
- Industrial electronics
- Appliances and white goods
- Real-time clock (RTC) backup
- Office equipment

Environmental compliance



* Supercapacitor lifetimes vary based on charge voltage and temperature. See Eaton's application guidelines or contact your local Eaton sales representative for more information on lifetime estimates

Ratings¹⁰

Capacitance	0.68 F to 1.0 F
Maximum working voltage	5.0 V
Surge voltage ⁹	5.5 V
Capacitance tolerance	-20% to +80% (+20 °C)
Operating temperature range	-40 °C to +85 °C

Specifications

Capacitance (F)	Part number	Maximum initial ESR ¹ +25 °C (Ω)	Nominal leakage current ^{1,2} (μA)	Stored energy ³ (mWh)	Peak power ⁴ (W)	Pulse current ⁵ (A)	Short circuit current ⁶ (A)
0.68	KVV-5R0C684-R	30	10	2.36	0.208	0.079	0.167
1.0	KVV-5R0C105-R	30	10	3.47	0.208	0.081	0.167

Performance

Parameter	Capacitance change (% of initial value)	ESR (% of maximum initial value)
Lifetime: (1000 hours at +85 °C, 5.0 V)	≤ 30%	≤ 200%
Storage: life (1000 hours, -40 °C to +85 °C)	≤ 30%	≤ 200%

1. Capacitance, Equivalent Series Resistance (ESR) and Leakage current are measured according to IEC62391-1 with current in milliamps (mA) = $8 \times C \times V$.

2. Leakage current at +25 °C after 24 hour charge and hold.

3. Stored Energy (mWh) = $\frac{0.5 \times C \times V^2}{3600} \times 1000$

4. Peak Power (W) = $\frac{V^2}{4 \times \text{ESR}}$

5. Pulse current for 1 second from full rate voltage to half voltage, (A) = $\frac{0.5 \times V \times C}{(1 + \text{ESR} \times C)}$

6. Short circuit current is for safety information only. Do not use as operating current.

7. Testing and verification of product under end application conditions is recommended

8. Not recommended for +85 °C/85% RH applications

9. Surge voltage: Maximum voltage, non-repetitive, 1 second maximum.

Safety and certifications

Environmental compliance and general specifications	RoHS, REACH, Halogen free
Shock and vibration	MIL-STD 202G
Warnings	Do not overvoltage, do not reverse polarity
Shipping	No restrictions, per UN3499 with all cells <0.3 watt-hours

Dimensions (mm) and mass (g)

Part number	OD ±0.5	H ±0.5	L(-) ±0.5	L(+) ±0.5	P ±0.5	T ±0.1	L1 ±0.3	L2 ±0.3	W ±0.2	W1 ±0.2	Mass (typical)
KVW-5ROC684-R	20.8	10.5	5.8	5.5	5.5	0.5	3.3	3.8	0.8	1.2	12.2
KVW-5ROC105-R	20.8	10.5	5.8	5.5	5.5	0.5	3.3	3.8	0.8	1.2	12.6

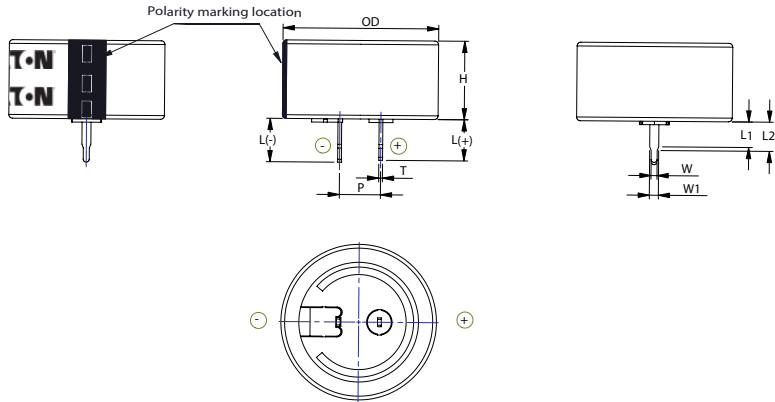

Part numbering system

Packaging information

- Bulk-100 parts per tray, 500 parts per box

·
·
·

Part marking

- Eaton logo
- Capacitance value (F)
- Operating voltage (V)
- Polarity mark

Wave solder profile

WARNING: DO NOT EXCEED +100 °C BODYTEMPERATURE. PERMANENT DAMAGE MAY OCCUR

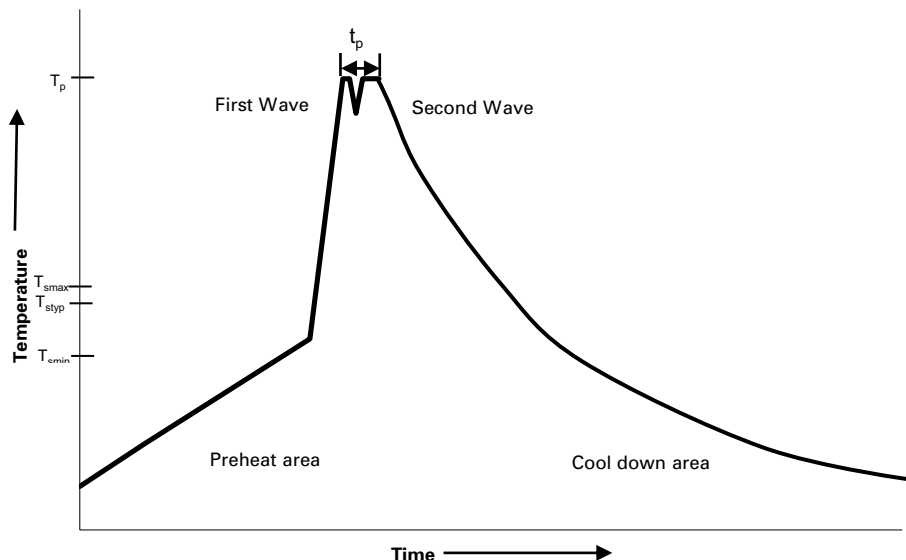

Profile Feature	Standard SnPb Solder	Lead (Pb) Free Solder
Preheat and soak		
• Temperature max. (T_{smax})	100 °C	100 °C
• Time max.	60 seconds	60 seconds
Δ preheat to max temperature	160 °C max.	160 °C max.
Peak temperature (T_p)*	220 °C – 260 °C	250 °C – 260 °C
Time at peak temperature (t_p)	5 seconds max	5 seconds max
Ramp-down rate	~ 2 K/s min ~3.5 K/s typ ~5 K/s max	~ 2 K/s min ~3.5 K/s typ ~5 K/s max
Time 25 °C to 25 °C	4 minutes	4 minutes

Manual solder

Do not touch the supercapacitor's external sleeve with the soldering rod or the sleeve will melt or crack. The recommended temperature of the soldering rod tip is less than +360 °C and the soldering duration should be less than 5 seconds. Minimize the time that the soldering iron is in direct contact with the terminals of the supercapacitor as excessive heating of the leads may lead to higher equivalent series resistance (ESR). Generally manual soldering is not recommended..

Reflow soldering

Do not use reflow soldering using infrared or convection oven heating methods.

Cleaning/Washing

Avoid cleaning of circuit boards, however if the circuit board must be cleaned use static or ultrasonic immersion in a standard circuit board cleaning fluid for no more than 5 minutes and a maximum temperature of +60 °C. Afterwards thoroughly rinse and dry the circuit boards. In general, treat supercapacitors in the same manner you would an aluminum electrolytic capacitor.

Life Support Policy: Eaton does not authorize the use of any of its products for use in life support devices or systems without the express written approval of an officer of the Company. Life support systems are devices which support or sustain life, and whose failure to perform, when properly used in accordance with instructions for use provided in the labeling, can be reasonably expected to result in significant injury to the user.

Eaton reserves the right, without notice, to change design or construction of any products and to discontinue or limit distribution of any products. Eaton also reserves the right to change or update, without notice, any technical information contained in this bulletin.

Eaton
Electronics Division
1000 Eaton Boulevard
Cleveland, OH 44122
United States
Eaton.com/electronics

© 2023 Eaton
All Rights Reserved
Printed in USA
Publication No. ELX1176
June 2023

Eaton is a registered trademark.

All other trademarks are property of their respective owners.

Follow us on social media to get the latest product and support information.

