

SN65HVS885EVM

The SN65HVS885EVM evaluation module (EVM) supports the rapid, parametric evaluation of the SN65HVS885 digital input serializer. It is intended to be used in conjunction with the SN65HVS885 data sheet, (SLASxxx). Note this EVM is not intended for electromagnetic compatibility (EMC) tests.

1 EVM Schematic and Layout

[Figure 1](#) shows the board circuit schematic and [Figure 2](#) shows the board layout top view. The board includes a terminal block, TB1, and three connectors, JMP1 to 3.

TB1 receives the board supply of 5 V nominal. VCC supplies the SN65HVS885 device and VIN provides the supply for sensor switches.

Upon the application of VCC the red VCC LED indicates 5V availability to the device.

JMP1 provides the field inputs IN0:IN7 for field voltages of 24 V nominal. They can be applied via:

- a. an external supply in series to a sensor switch connected to a field input,
- b. or a sensor switch connected between and input and VIN,
- c. or a direct connection between an input and VIN.

In all three cases, a 24-V level represents the ON-status of a sensor switch, which is indicated by the corresponding LEDs D0:D7.

JMP2 provides access to the control and data lines of the internal serializer. To operate the serializer \overline{CE} must be connected either to ground or to CLK.

Upon an active-low load pulse, (a high-to-low-to-high transition) at \overline{LD} , the status information of the field inputs is latched into the serializer. Applying eight consecutive clock cycles at CLK, shifts out the serializer data at SOP with each rising edge of the clock.

Cascading of multiple boards is also possible by connecting the SOP output of a leading device with the SIP input of a following device.

JMP3 allows the selection of three different debounce times and 3 different current limits.

Debounce default is 3-ms and does not require any connection between the DB inputs to ground. Otherwise for zero debounce time connect DB1 to ground, and for 1-ms debounce time connect DB0 to ground.

Note, that open DB inputs are internally pulled high and will not float.

Setting a specific current limit requires a connection between the R_{LIM} output and one of the resistors, RLIM 1:3. For a current limit of 3.6 mA connect R_{LIM} to R8, for 3 mA to R9, and for 2.5 mA to R10.

For detailed information on device functionality and system design recommendations refer to the SN65HVS885 datasheet.

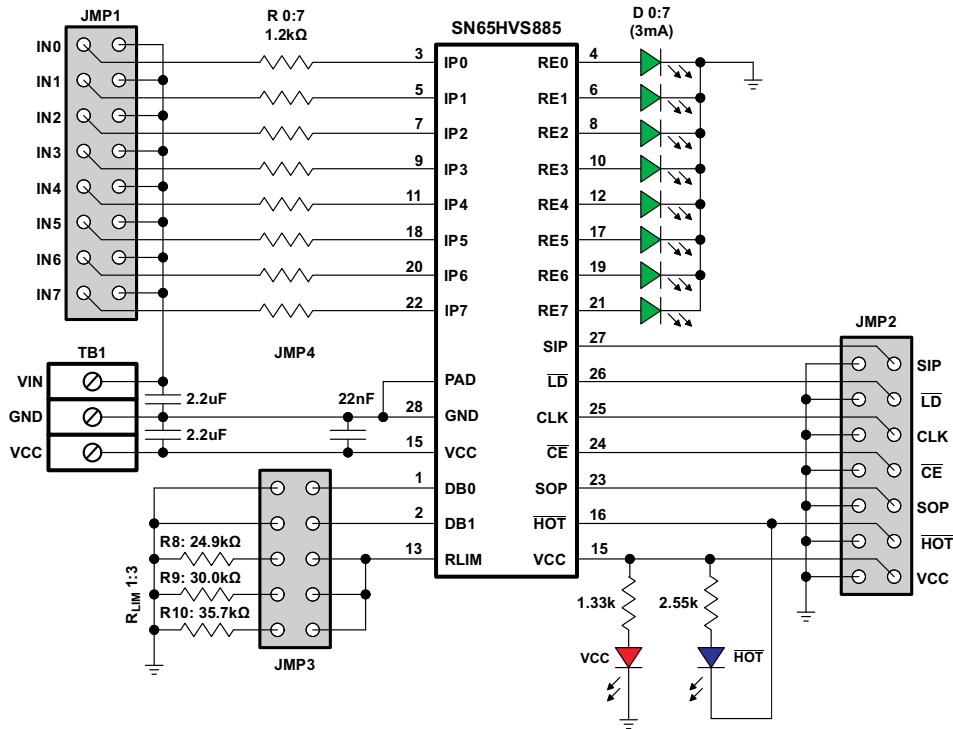

Figure 1. SN65HVS885EVM Schematic

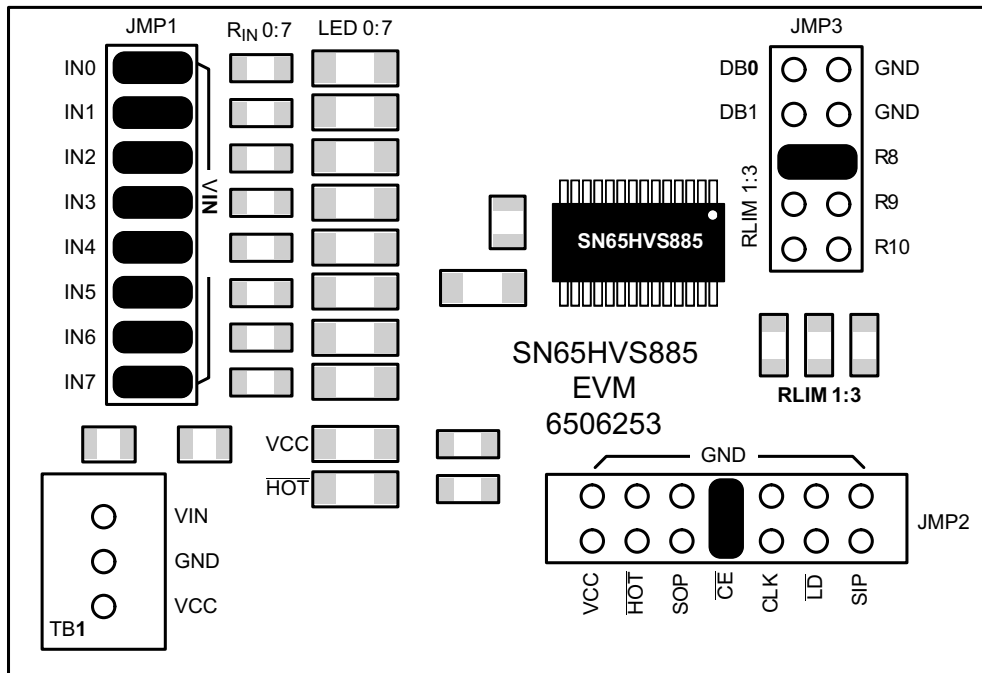

Figure 2. SN65HVS885EVM Layout

IMPORTANT NOTICE

Texas Instruments Incorporated and its subsidiaries (TI) reserve the right to make corrections, modifications, enhancements, improvements, and other changes to its products and services at any time and to discontinue any product or service without notice. Customers should obtain the latest relevant information before placing orders and should verify that such information is current and complete. All products are sold subject to TI's terms and conditions of sale supplied at the time of order acknowledgment.

TI warrants performance of its hardware products to the specifications applicable at the time of sale in accordance with TI's standard warranty. Testing and other quality control techniques are used to the extent TI deems necessary to support this warranty. Except where mandated by government requirements, testing of all parameters of each product is not necessarily performed.

TI assumes no liability for applications assistance or customer product design. Customers are responsible for their products and applications using TI components. To minimize the risks associated with customer products and applications, customers should provide adequate design and operating safeguards.

TI does not warrant or represent that any license, either express or implied, is granted under any TI patent right, copyright, mask work right, or other TI intellectual property right relating to any combination, machine, or process in which TI products or services are used. Information published by TI regarding third-party products or services does not constitute a license from TI to use such products or services or a warranty or endorsement thereof. Use of such information may require a license from a third party under the patents or other intellectual property of the third party, or a license from TI under the patents or other intellectual property of TI.

Reproduction of TI information in TI data books or data sheets is permissible only if reproduction is without alteration and is accompanied by all associated warranties, conditions, limitations, and notices. Reproduction of this information with alteration is an unfair and deceptive business practice. TI is not responsible or liable for such altered documentation. Information of third parties may be subject to additional restrictions.

Resale of TI products or services with statements different from or beyond the parameters stated by TI for that product or service voids all express and any implied warranties for the associated TI product or service and is an unfair and deceptive business practice. TI is not responsible or liable for any such statements.

TI products are not authorized for use in safety-critical applications (such as life support) where a failure of the TI product would reasonably be expected to cause severe personal injury or death, unless officers of the parties have executed an agreement specifically governing such use. Buyers represent that they have all necessary expertise in the safety and regulatory ramifications of their applications, and acknowledge and agree that they are solely responsible for all legal, regulatory and safety-related requirements concerning their products and any use of TI products in such safety-critical applications, notwithstanding any applications-related information or support that may be provided by TI. Further, Buyers must fully indemnify TI and its representatives against any damages arising out of the use of TI products in such safety-critical applications.

TI products are neither designed nor intended for use in military/aerospace applications or environments unless the TI products are specifically designated by TI as military-grade or "enhanced plastic." Only products designated by TI as military-grade meet military specifications. Buyers acknowledge and agree that any such use of TI products which TI has not designated as military-grade is solely at the Buyer's risk, and that they are solely responsible for compliance with all legal and regulatory requirements in connection with such use.

TI products are neither designed nor intended for use in automotive applications or environments unless the specific TI products are designated by TI as compliant with ISO/TS 16949 requirements. Buyers acknowledge and agree that, if they use any non-designated products in automotive applications, TI will not be responsible for any failure to meet such requirements.

Following are URLs where you can obtain information on other Texas Instruments products and application solutions:

Products

Amplifiers	amplifier.ti.com
Data Converters	dataconverter.ti.com
DLP® Products	www.dlp.com
DSP	dsp.ti.com
Clocks and Timers	www.ti.com/clocks
Interface	interface.ti.com
Logic	logic.ti.com
Power Mgmt	power.ti.com
Microcontrollers	microcontroller.ti.com
RFID	www.ti-rfid.com
RF/IF and ZigBee® Solutions	www.ti.com/lprf

Applications

Audio	www.ti.com/audio
Automotive	www.ti.com/automotive
Broadband	www.ti.com/broadband
Digital Control	www.ti.com/digitalcontrol
Medical	www.ti.com/medical
Military	www.ti.com/military
Optical Networking	www.ti.com/opticalnetwork
Security	www.ti.com/security
Telephony	www.ti.com/telephony
Video & Imaging	www.ti.com/video
Wireless	www.ti.com/wireless

Mailing Address: Texas Instruments, Post Office Box 655303, Dallas, Texas 75265
Copyright © 2009, Texas Instruments Incorporated