

APPROVED: \_\_\_\_\_  
 DATE: \_\_\_\_\_ TITLE: \_\_\_\_\_

Rev	AWO #	Description	Date	Appr
-		RELEASED	05/23/05	
A		UPDATE DRAWING	4/15/16	AY/LL

LED CHARACTERISTIC	
NO.	NODE
LED1	9+ $\rightarrow$ $\rightarrow$ -10
LED2	11+ $\rightarrow$ $\rightarrow$ -12

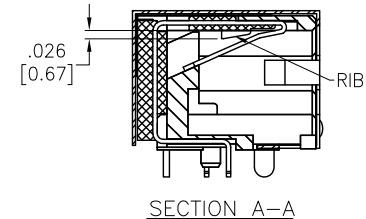
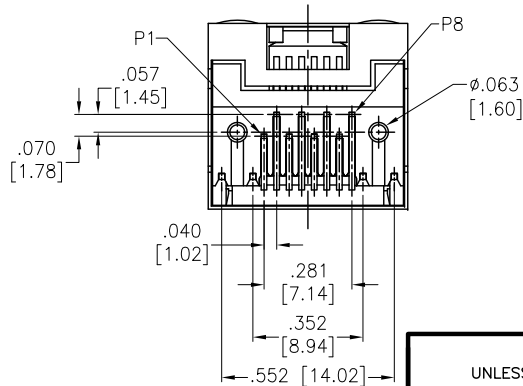
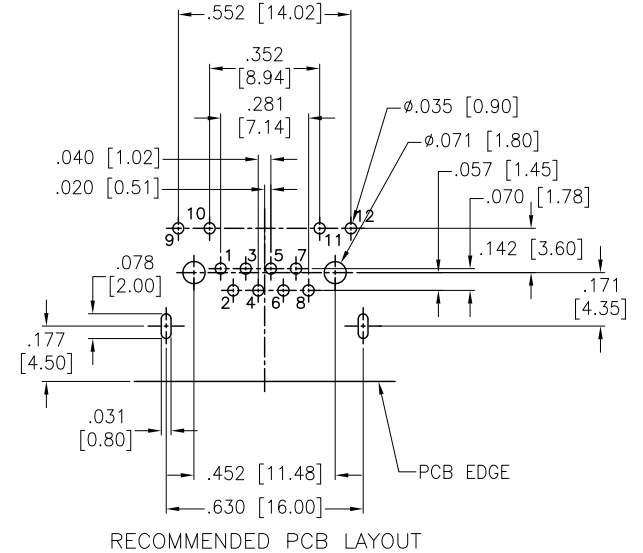
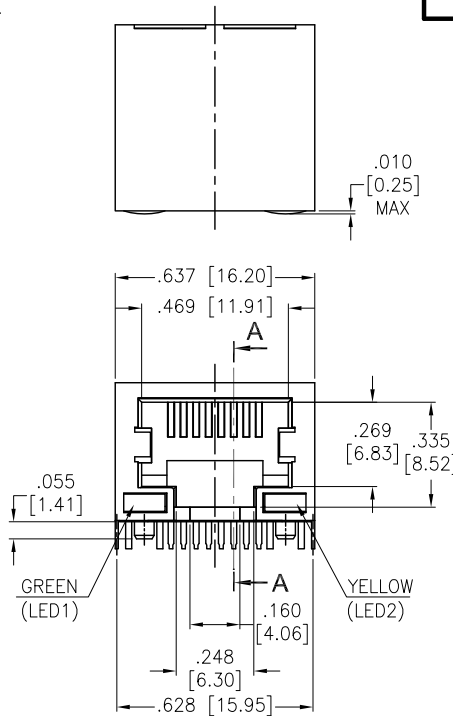
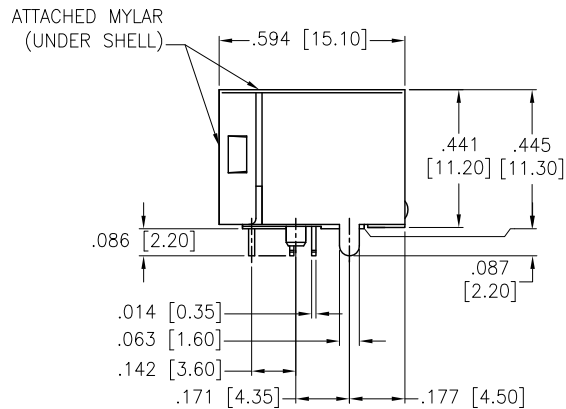

**SPECIFICATIONS:**

Material:  
 Insulator: Nylon 46, Glass fiber, rated UL 94V-0  
 Insulator color: Black  
 Contacts: Phosphor Bronze  
 Shield: Brass, Nickel plated  
 LED Solder Tail: Steel, Tin plated  
 Contacts Plating:  
 Gold over Nickel underplate on contact area  
 Gold flash over Nickel underplate on solder tails  
 Electrical:  
 Voltage rating: 150 VAC max  
 Current rating: 1.5 Amp max  
 Contact resistance: 20 mohms max  
 Insulation resistance: 500 Mohms min @ 500 VDC  
 Dielectric withstanding voltage: 1500 VAC for 1 minute  
 Temperature Rating:  
 Operating temperature: -40°C to +85°C  
 Environmental:  
 Lead free, RoHS compliant.



UNLESS OTHERWISE SPECIFIED  
 ALL DIMENSIONS ARE INCHES [MM]  
 TOLERANCES: EXCEPT AS NOTED  
 INCHES HOLES

.X ± .10	∅.X ± .10
.XX ± .020	∅.XX ± .015
.XXX ± .015	∅.XXX ± .010

**ADAM TECH**  
 INTERCONNECTS

909 Rahway Avenue,  
 Union, NJ 07083  
 Phone: 908-687-5000  
 Fax: 908-687-5710

TITLE  
**MODULAR TELEPHONE JACK, 8P8C  
 W/ LED1 GREEN LED2 YELLOW**

APPROVALS		DATE
DRAWN	SS	05/23/05
CHECKED		
APPROVED		

SIZE	PART NO.	REV.
X	MTJ-88AAX1-FSV-LH	A
REF: S00065T	SCALE: NTS	SHEET 1 OF 1