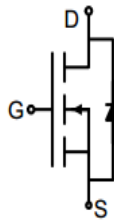
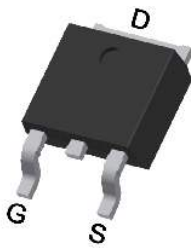

## N-Channel Enhancement Mode Power MOSFET

<p><b>Description</b></p> <p>The G35N02K uses advanced trench technology to provide excellent <math>R_{DS(ON)}</math>, low gate charge. It can be used in a wide variety of applications.</p> <p><b>General Features</b></p> <ul style="list-style-type: none"> <li>• <math>V_{DS}</math> 20V</li> <li>• <math>I_D</math> (at <math>V_{GS} = 10V</math>) 35A</li> <li>• <math>R_{DS(ON)}</math> (at <math>V_{GS} = 4.5V</math>) &lt; 13m<math>\Omega</math></li> <li>• <math>R_{DS(ON)}</math> (at <math>V_{GS} = 2.5V</math>) &lt; 18m<math>\Omega</math></li> <li>• 100% Avalanche Tested</li> <li>• RoHS Compliant</li> </ul> <p><b>Application</b></p> <ul style="list-style-type: none"> <li>• Power switch</li> <li>• DC/DC converters</li> </ul>		 <p>Schematic diagram</p>  <p>TO-252</p>	
<b>Device</b>	<b>Package</b>	<b>Marking</b>	<b>Packaging</b>
G35N02K	TO-252	G35N02	2500pcs/Reel

<b>Absolute Maximum Ratings</b> $T_C = 25^{\circ}C$ , unless otherwise noted			
Parameter	Symbol	Value	Unit
Drain-Source Voltage	$V_{DS}$	20	V
Continuous Drain Current	$I_D$	35	A
Pulsed Drain Current (note1)	$I_{DM}$	100	A
Gate-Source Voltage	$V_{GS}$	$\pm 12$	V
Power Dissipation	$P_D$	40	W
Single pulse avalanche energy (note3)	$E_{AS}$	23	mJ
Operating Junction and Storage Temperature Range	$T_J, T_{stg}$	-55 To 150	$^{\circ}C$
<b>Thermal Resistance</b>			
Parameter	Symbol	Value	Unit
Thermal Resistance, Junction-to-Case	$R_{thJC}$	3.8	$^{\circ}C/W$

Specifications $T_J = 25^{\circ}\text{C}$ , unless otherwise noted						
Parameter	Symbol	Test Conditions	Value			Unit
			Min.	Typ.	Max.	
<b>Static Parameters</b>						
Drain-Source Breakdown Voltage	$V_{(BR)DSS}$	$V_{GS} = 0V, I_D = 250\mu A$	20	--	--	V
Zero Gate Voltage Drain Current	$I_{DSS}$	$V_{DS} = 20V, V_{GS} = 0V$	--	--	1	$\mu A$
Gate-Source Leakage	$I_{GSS}$	$V_{GS} = \pm 12V$	--	--	$\pm 100$	nA
Gate-Source Threshold Voltage	$V_{GS(th)}$	$V_{DS} = V_{GS}, I_D = 250\mu A$	0.5	0.75	1.2	V
Drain-Source On-Resistance	$R_{DS(on)}$	$V_{GS} = 4.5V, I_D = 20A$	--	7	13	m $\Omega$
		$V_{GS} = 2.5V, I_D = 20A$	--	9	18	
Forward Transconductance	$g_{FS}$	$V_{DS} = 5V, I_D = 20A$	--	60	--	S
<b>Dynamic Parameters</b>						
Input Capacitance	$C_{iss}$	$V_{DS}=10V,$ $V_{GS}=0V,$ $F=1.0MHz$	--	1380	--	pF
Output Capacitance	$C_{oss}$		--	212	--	
Reverse Transfer Capacitance	$C_{rss}$		--	195	--	
Total Gate Charge	$Q_g$	$V_{DS}=10V,$ $I_D=20A,$ $V_{GS}=4.5V$	--	24	--	nC
Gate-Source Charge	$Q_{gs}$		--	3	--	
Gate-Drain Charge	$Q_{gd}$		--	6	--	
Turn-on Delay Time	$t_{d(on)}$	$V_{DS} = 10V,$ $I_D = 20A,$ $R_G = 3\Omega$	--	4.5	--	ns
Turn-on Rise Time	$t_r$		--	9	--	
Turn-off Delay Time	$t_{d(off)}$		--	19	--	
Turn-off Fall Time	$t_f$		--	3	--	
<b>Drain-Source Body Diode Characteristics</b>						
Continuous Body Diode Current	$I_S$	$T_C = 25^{\circ}\text{C}$	--	--	35	A
Body Diode Voltage	$V_{SD}$	$T_J = 25^{\circ}\text{C}, I_{SD} = 25A, V_{GS} = 0V$	--	--	1.2	V
Reverse Recovery Time	$T_{rr}$	$I_S = 20A, V_{GS} = 0V$ $di/dt=100A/us$	--	18	--	nS
Reverse Recovery Charge	$Q_{rr}$		--	10	--	nC

**Notes**

1. Repetitive Rating: Pulse width limited by maximum junction temperature
2. Identical low side and high side switch with identical  $R_G$
3. EAS condition :  $T_J=25^{\circ}\text{C}, V_{DD}=20V, V_{GS}=10V, L=0.5mH, R_G=25\Omega$

**Gate Charge Test Circuit**

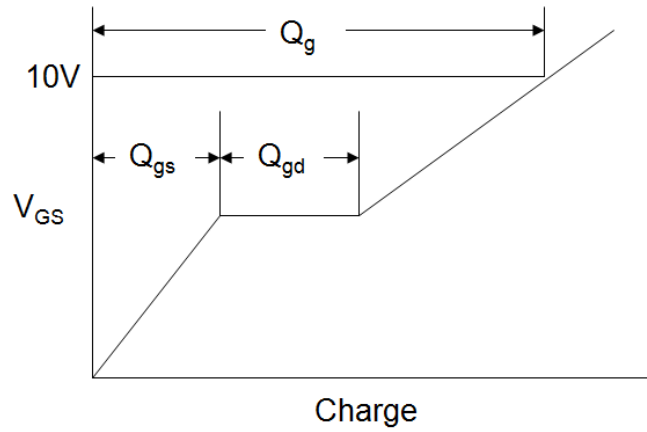

**Switch Time Test Circuit**



**EAS Test Circuit**

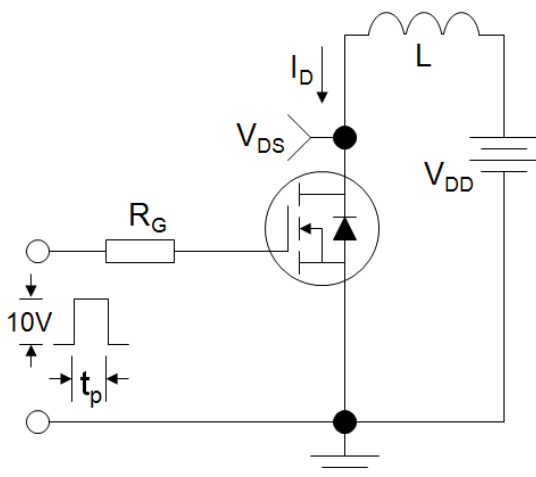

Typical Characteristics  $T_J = 25^\circ\text{C}$ , unless otherwise noted

Figure 1. Output Characteristics

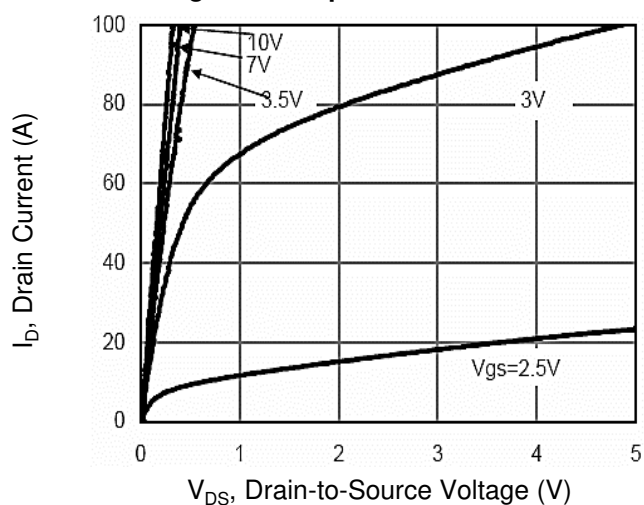

Figure 2. Transfer Characteristics

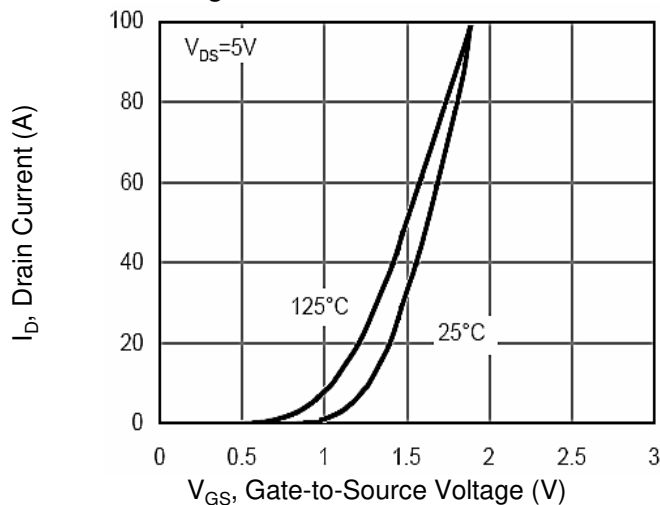

Figure 3. Gate Charge

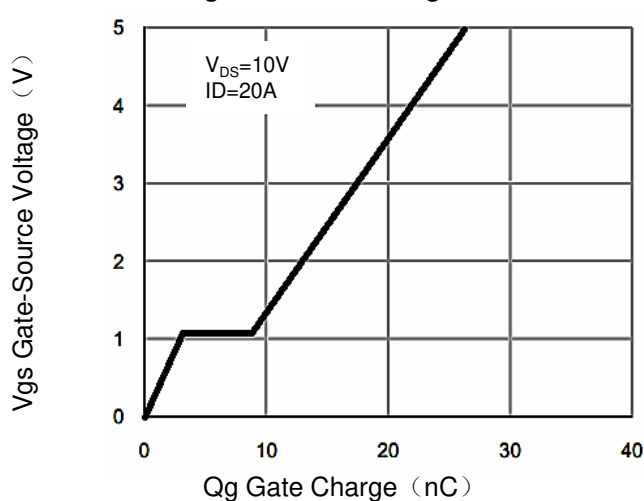

Figure 4. Drain Source On Resistance

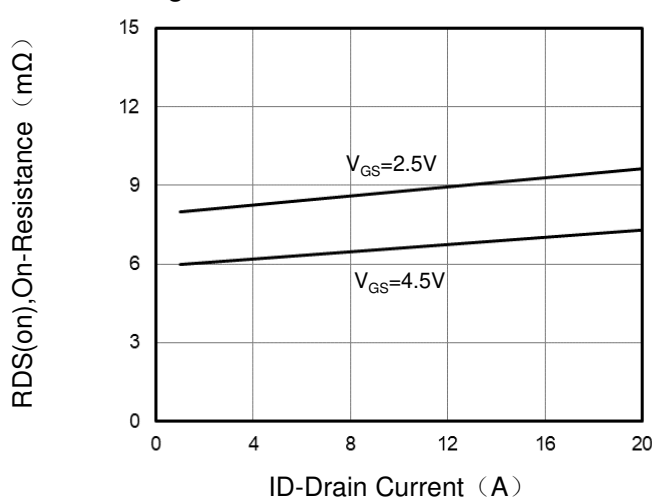

Figure 5. Capacitance

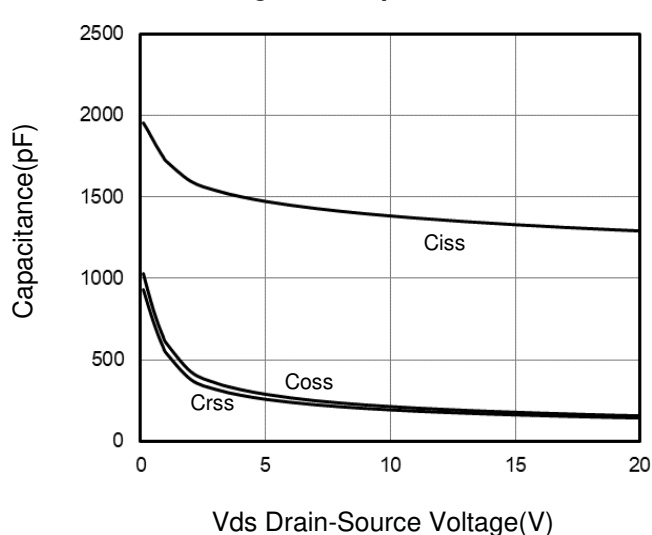
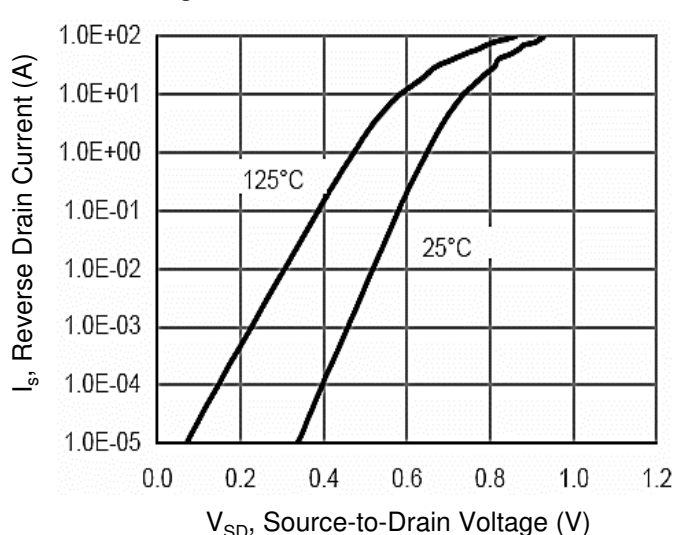

Figure 6. Source-Drain Diode Forward



Typical Characteristics  $T_J = 25^\circ\text{C}$ , unless otherwise noted

Figure 7. Drain-Source On-Resistance

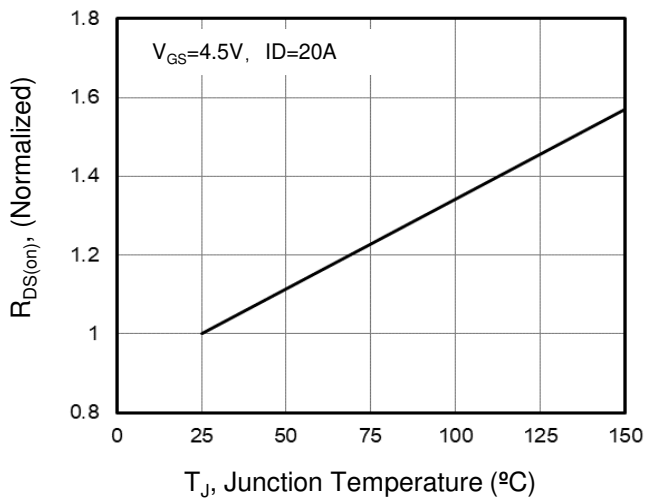

Figure 8. Safe Operation Area

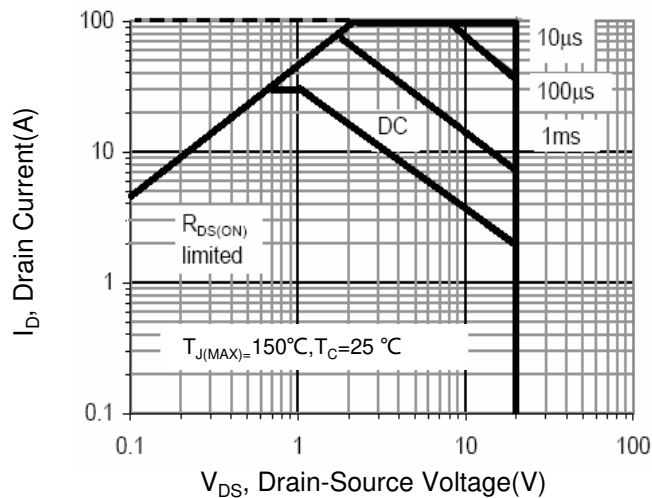
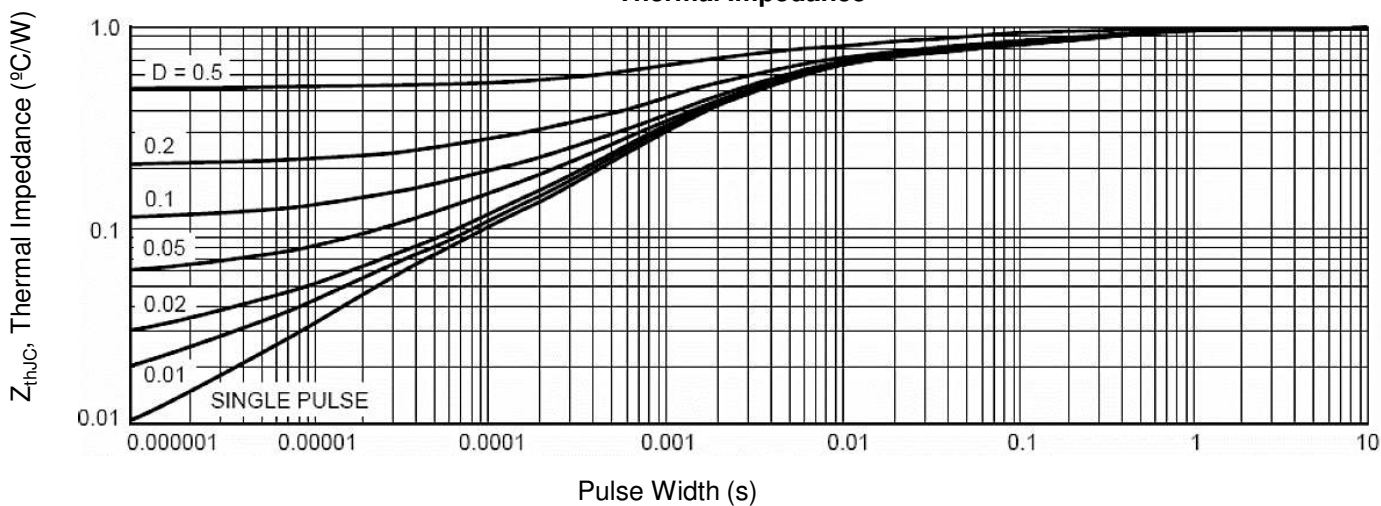
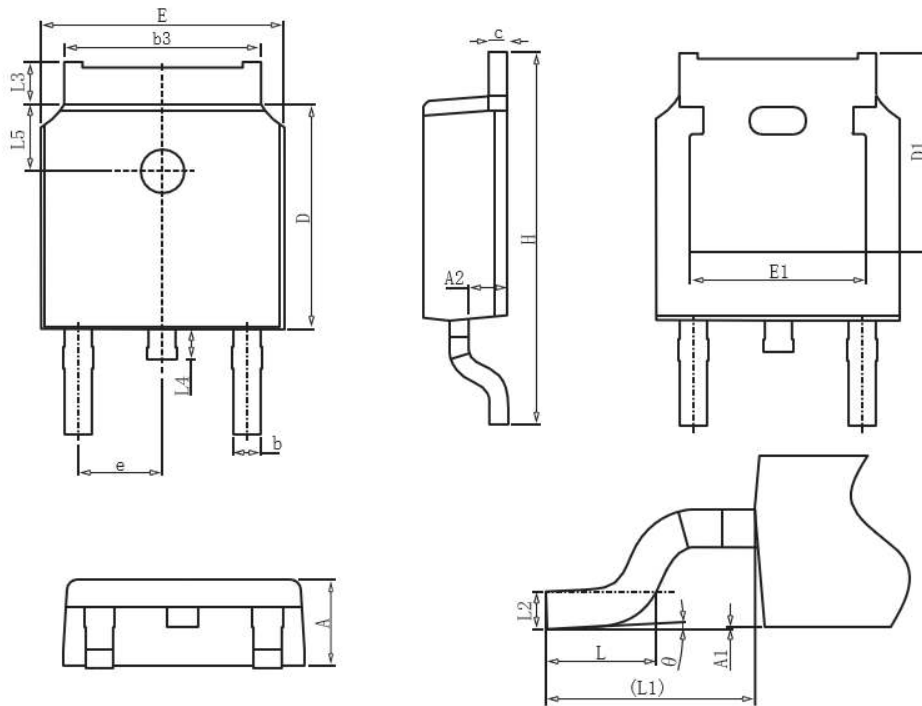

Figure 9. Normalized Maximum Transient Thermal Impedance



**TO-252 Package Information**



Symbol	Dimensions in Millimeters		
	MIN.	NOM.	MAX.
A	2.2	2.3	2.4
A1	0		0.2
A2	0.97	1.07	1.17
b	0.68	0.78	0.9
b3	5.2	5.33	5.5
c	0.43	0.53	0.63
D	5.98	6.1	6.22
D1	5.30REF		
E	6.4	6.6	6.8
E1	4.63		
e	2.286BSC		
H	9.4	10.1	10.5
L	1.38	1.5	1.75
L1	2.90REF		
L2	0.51BSC		
L3	0.88		1.28
L4	0.5		1
L5	1.65	1.8	1.95
θ	0°		8°