

LOC	DIST	REVISIONS					
AJ	16	P	LTR	DESCRIPTION	DATE	OWN	APVD
			K	REVISED PER EC 0514-0457-04	03NOV05	TS	JL

D  
C  
B  
A

D  
C  
B  
A

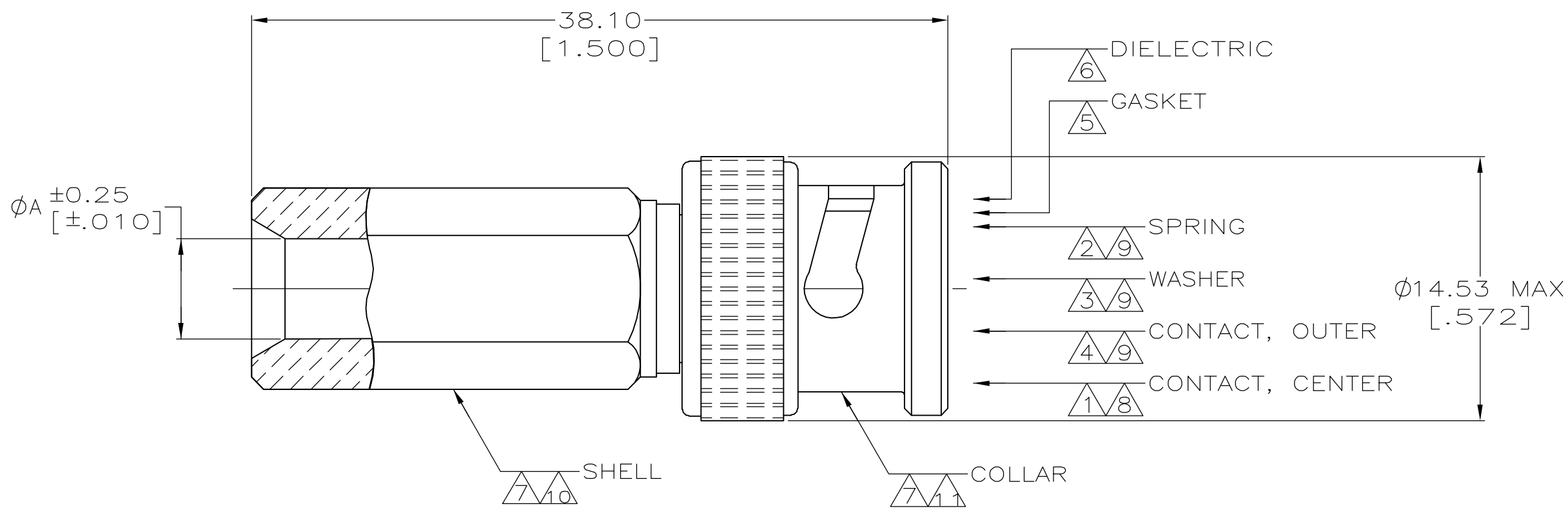

- 1 PHOSPHOR BRONZE PER ASTM-B-139
- 2 CARBON STEEL
- 3 BRASS PER MIL-C-50
- 4 BRASS PER QQ-B-626
- 5 SILICONE RUBBER PER ZZ-R-765
- 6 POLYMETHYLPENTENE: GENERAL PURPOSE
- 7 ZINC DIE CAST PER QQ-Z-363
- 8 GOLD PLATING PER MIL-G-45204  
0.38μm [.000015] MIN THICKNESS
- 9 NICKEL PLATING PER QQ-N-290  
2.54μm [.000100] MIN THICKNESS
- 10 NICKEL PLATING PER QQ-N-290  
3.81μm [.000150] MIN THICKNESS
- 11 NICKEL PLATING PER QQ-N-290  
4.45μm [.000175] MIN THICKNESS
- 12. USE INSTRUCTION SHEET 408-6996

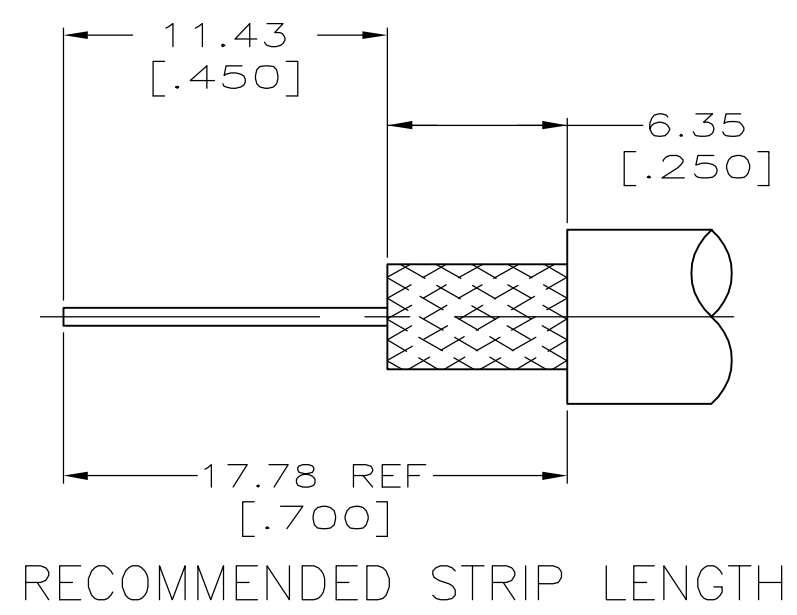

OBSOLETE	RG-58B/U	4.47 [.176]	414265-7
OBSOLETE	RG-59/U	5.49 [.216]	414265-6
OBSOLETE	BELDEN 8281	6.91 [.272]	414265-5
OBSOLETE	BELDEN 88241	4.62 [.182]	414265-4
	RG-59/U	5.49 [.216]	414265-3
OBSOLETE	BELDEN 88240	4.06 [.160]	414265-2
SUPERSEDED BY 414265-7	RG-58B/U	4.47 [.176]	414265-1

THIS DRAWING IS A CONTROLLED DOCUMENT.		DWN M.E. COWHER 23JAN92	Tyco Electronics Corporation Harrisburg, PA 17105-3608	
DIMENSIONS: mm [INCHES]		CHK M. PHILLIPS 4-21-92	NAME PLUG ASSEMBLY, 50 OHM, TWIST-ON, BNC	
TOLERANCES UNLESS OTHERWISE SPECIFIED:		APVD -	PRODUCT SPEC -	
0 PLC ± -		APPLICATION SPEC -		
1 PLC ± -		SIZE A2		
2 PLC ± 0.51 [.020]		CAGE CODE 00779		
3 PLC ± -		DRAWING NO 414265		
4 PLC ± -		RESTRICTED TO -		
ANGLES ± ± -		SCALE 4:1		
FINISH SEE NOTES		SHEET 1 of 1		
MATERIAL SEE NOTES		REV K		
		CUSTOMER DRAWING		

414265