

FEMALE-FEMALE BULKHEAD ADAPTOR

R141A.720.000

Series : **ECO BNC 50**

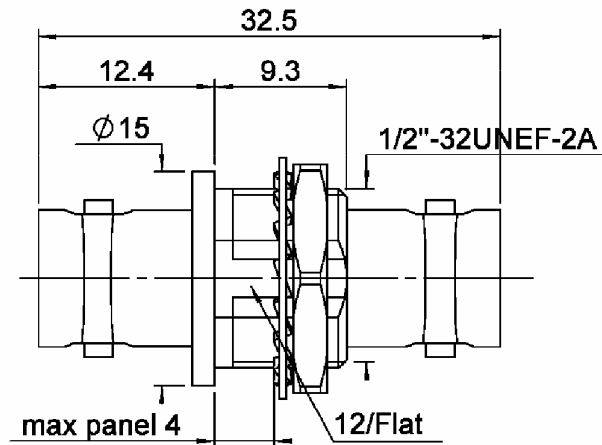

PANEL CUT OUT

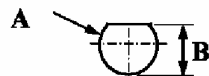

mm		
	Maxi	mini
A	12.8	12.7
B	12.15	12.05

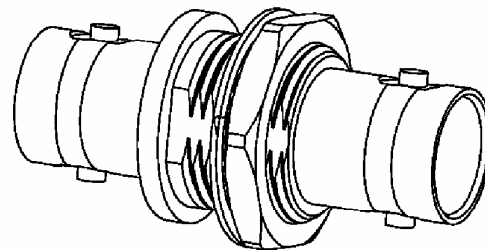
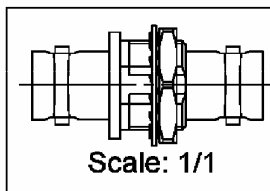

All dimensions are in mm.

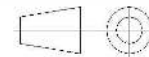

COMPONENTS	MATERIALS	PLATING (µm)
BODY	BRASS	NICKEL
CENTER CONTACT	BRONZE	GOLD
OUTER CONTACT		
INSULATOR	PTFE	
GASKET		
OTHERS PARTS	BRASS	NICKEL
-	-	-
-	-	-

Issue : 0909 A

In the effort to improve our products, we reserve the right to make changes judged to be necessary.



FEMALE-FEMALE BULKHEAD ADAPTOR

R141A.720.000

Series : **ECO BNC 50**

PACKAGING

Standard	Unit	Other
100	'W' option	Contact us

SPECIFICATION

ELECTRICAL CHARACTERISTICS

Impedance	50	Ω
Frequency	0-1	GHz
VSWR	1.3 + 0.0000	x F(GHz) Maxi
Insertion loss	0.2	\sqrt{F} (GHz) dB Maxi
RF leakage	- (NA)	- F(GHz)) dB Maxi
Voltage rating	500	Veff Maxi
Dielectric withstanding voltage	1500	Veff mini
Insulation resistance	5000	M Ω mini

ENVIRONMENTAL

Operating temperature	-40/+85	$^{\circ}$ C
Hermetic seal	NA	Atm.cm3/s
Panel leakage	NA	

OTHER CHARACTERISTICS

Assembly instruction **NA**

Others :

MECHANICAL CHARACTERISTICS

Center contact retention		
Axial force – Mating end	18	N mini
Axial force – Opposite end	18	N mini
Torque	NA	N.cm mini
Recommended torque		
Mating	NA	N.cm
Panel nut	NA	N.cm
Mating life	100	Cycles mini
Weight	17.1000	g

Issue : 0909 A

In the effort to improve our products, we reserve the right to make changes judged to be necessary.

