

THIS DRAWING IS UNPUBLISHED. RELEASED FOR PUBLICATION  
 © COPYRIGHT BY TYCO ELECTRONICS CORPORATION. ALL RIGHTS RESERVED.

LOC	DIST	REVISIONS					
DF	A0	P	LTR	DESCRIPTION	DATE	DWN	APVD
		D		REV PER ECO 07-004436	2-28-07	CT	MT

1. FOR USE IN ARINC 600 REAR RELEASE INSERT.  
 △ DIMENSIONS APPLY BEFORE SOLDER DIP.

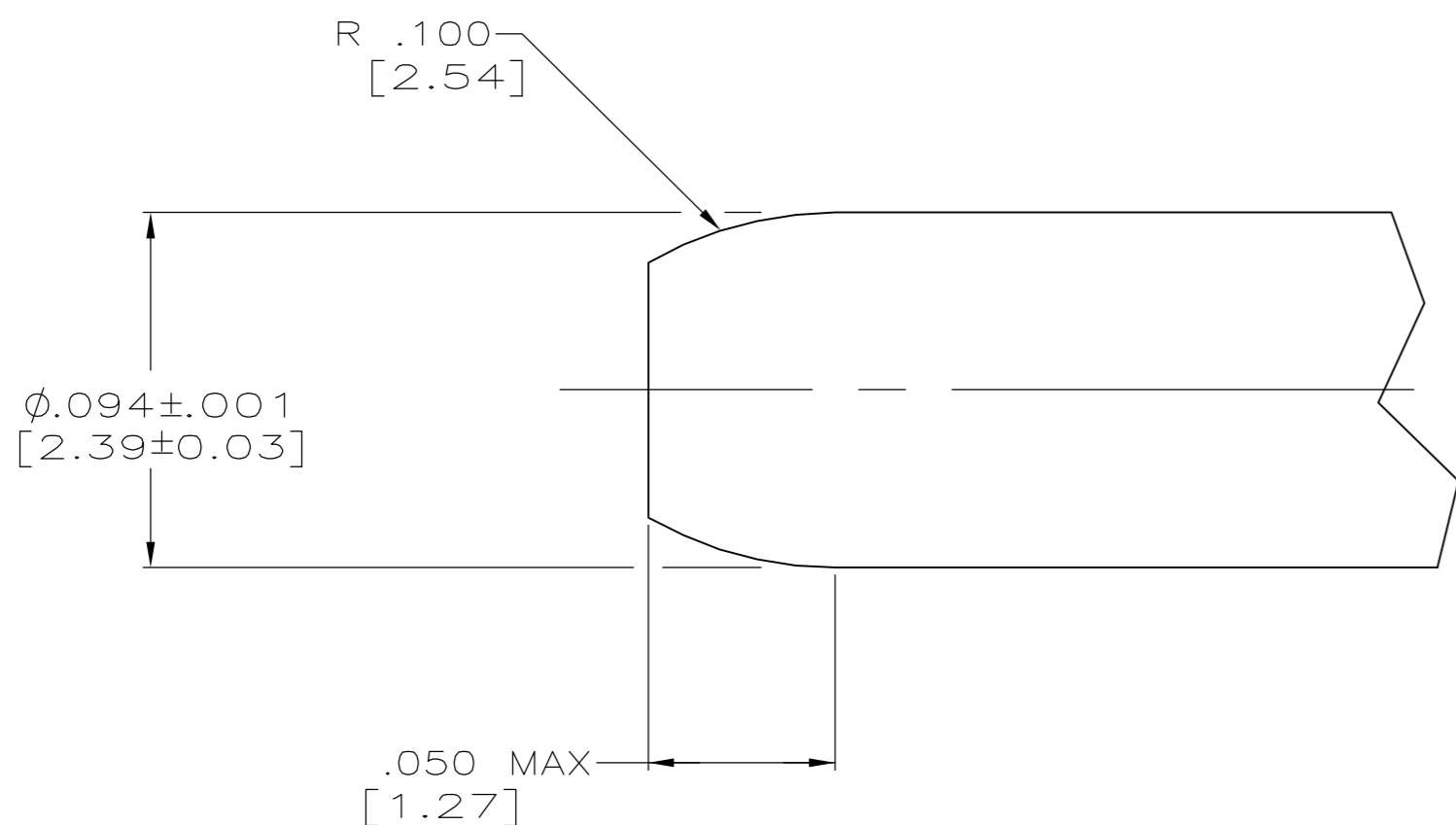
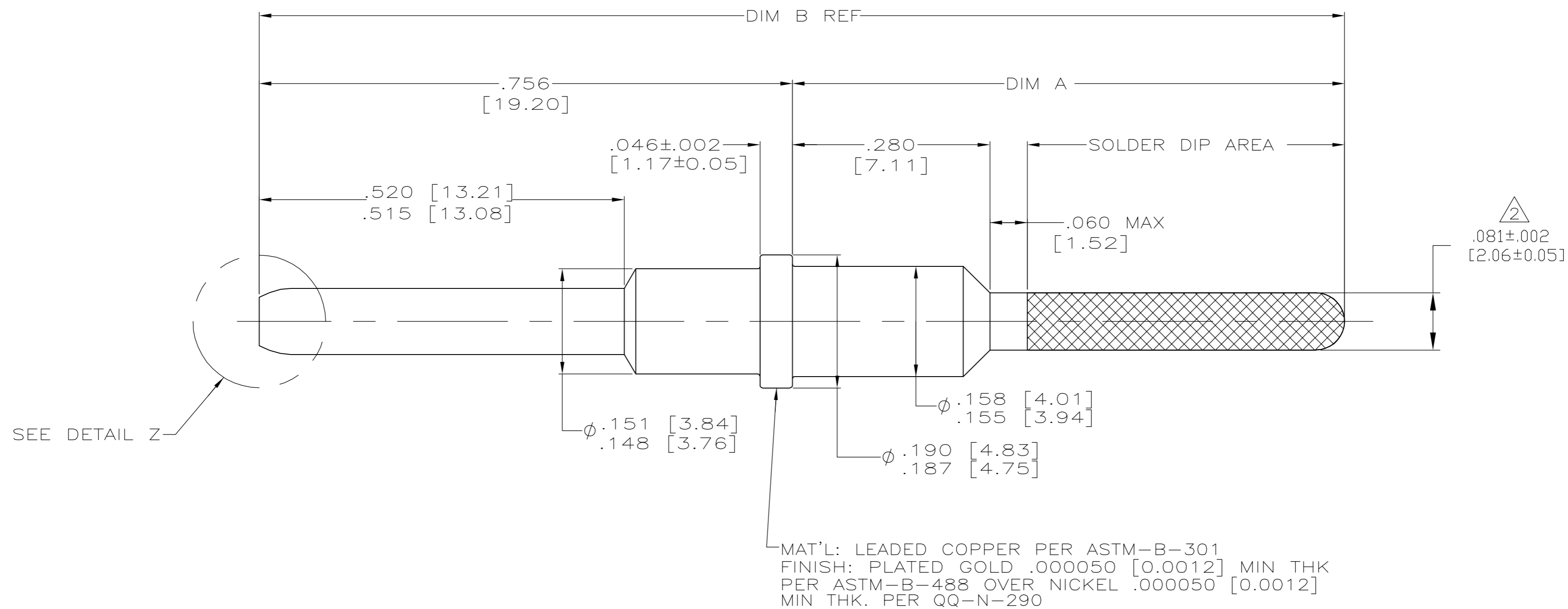

DETAIL Z  
 SCALE 20:1

1.639 [41.63]	.883±.003 [22.43±0.08]	NO	1-1663129-1
1.279 [32.49]	.523±.005 [13.28±0.13]	NO	1663129-8
1.391 [35.33]	.635±.005 [16.13±0.13]	YES	1663129-6
1.391 [35.33]	.635±.005 [16.13±0.13]	NO	1663129-5
1.539 [39.09]	.783±.003 [19.89±0.08]	YES	1663129-3
1.539 [39.09]	.783±.003 [19.89±0.08]	NO	1663129-2
DIM B	DIM A	SOLDER DIP	PART NUMBER

THIS DRAWING IS A CONTROLLED DOCUMENT.

DWN C.C.THOMAS 11-19-02  
 CHK S.GLATFELTER 11-19-02  
 APVD S.GLATFELTER 11-19-02

TOLERANCES UNLESS OTHERWISE SPECIFIED:  
 0 PLC ± -  
 1 PLC ± -  
 2 PLC ± -  
 3 PLC ± .005 [0.13]  
 4 PLC ± -  
 ANGLES ± -  
 FINISH SEE CALLOUT

AMP Tyco Electronics Corporation  
 Harrisburg, PA 17105-3608

NAME PIN CONTACT, POSTED, SIZE 12, REAR RELEASE, ARINC 600

SIZE A2 CAGE CODE 00779 DRAWING NO C=1663129 RESTRICTED TO -

MATERIAL SEE CALLOUT WEIGHT - SCALE 8:1 SHEET 1 of 1 REV D

CUSTOMER DRAWING