

Cable Assembly

Video Power Extension Cable



Specifications

Cable Length : 60ft, 100ft, 150ft
 Connector Type A : BNC (M) + DC (M)
 Connector Type B : BNC (M) + DC (F)

Diagram

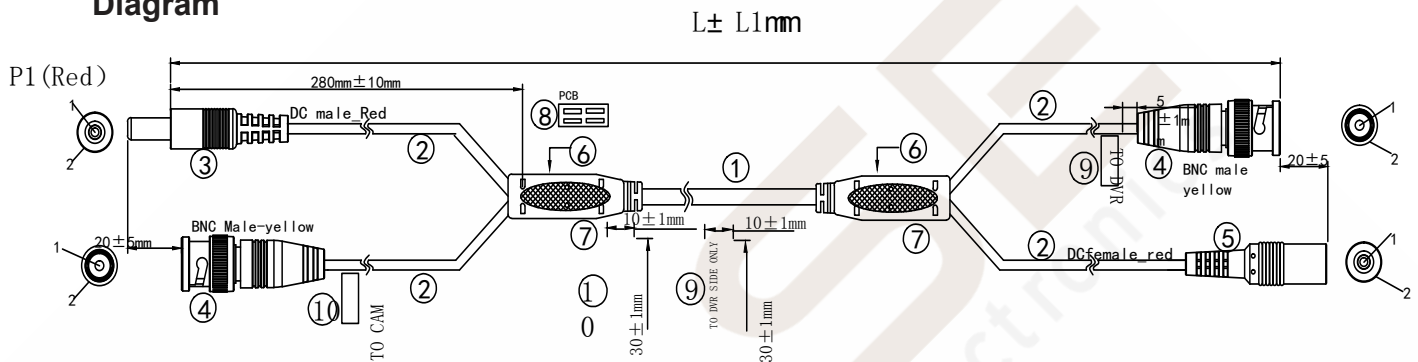

Part Number	L ± 1mm
W1801BD	18288 ± 20 mm
W3101BD	30480 ± 20 mm
W5001BD	45720 ± 20 mm

Cable Structure :

Main Wire

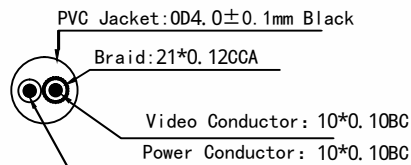

Sub Wire

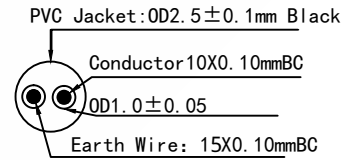

Main Wire

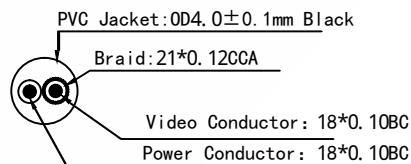

Sub Wire

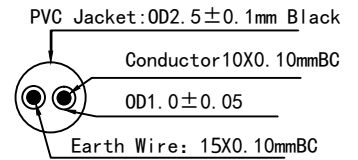

Cable Assembly

Video Power Extension Cable

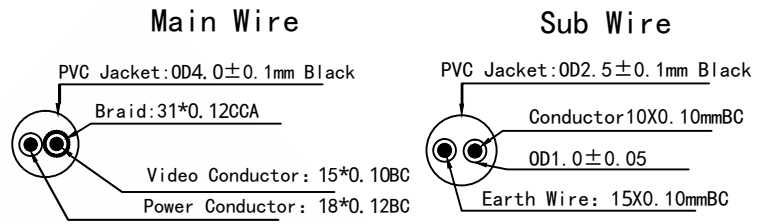

Dimensions : Millimeter

1. Cable

W1801BD: [(10*0.10BC) * 2P+OD4.0mm] * 1+(10X0.10mmBC+15X0.10mmBC) * 1C + BRAID(21*0.12CCA) Black
PVC Jacket, O.D: 4.0mm ±0.1mm

W3101BD: [(18*0.10BC) * 2P+OD4.0mm] * 1+(10X0.10mmBC+15X0.10mmBC) * 1C + BRAID(21*0.12CCA) Black
PVC Jacket, O.D: 4.0mm ±0.1mm

W5001BD: [(15*0.10BC) * 1P+(18*0.12BC) * 1P+OD4.0mm] * 1+(10X0.10mmBC+15X0.10mmBC) * 1C +
BRAID(31*0.12CCA) Black PVC Jacket, O.D: 4.0mm ±0.1mm

2. Connector Type A

BNC Male
Soldering
Blue PVC Jacket
Brass Plated Pin

3. Connector Type B

2.1mm*5.5mm DC Male/Female
Soldering
Red PVC Jacket

4. Inner Molded

LDPE

5. Outer Molded

45P PVC, Black

Part Number Table

Description	Part Number
60 ft. Video Power Extension Cable	W1801BD
100 ft. Video Power Extension Cable	W3101BD
150 ft. Video Power Extension Cable	W5001BD

Important Notice : This data sheet and its contents (the "Information") belong to the members of the EASE group of companies (the "Group") or are licensed to it. No licence is granted for the use of it other than for information purposes in connection with the products to which it relates. No licence of any intellectual property rights is granted. The Information is subject to change without notice and replaces all data sheets previously supplied. The Information supplied is believed to be accurate but the Group assumes no responsibility for its accuracy or completeness, any error in or omission from it or for any use made of it. Users of this data sheet should check for themselves the Information and the suitability of the products for their purpose and not make any assumptions based on information included or omitted. Liability for loss or damage resulting from any reliance on the Information or use of it (including liability resulting from negligence or where the Group was aware of the possibility of such loss or damage arising) is excluded. This will not operate to limit or restrict the Group's liability for death or personal injury resulting from its negligence. EASE is the registered trademark of Ease Electronics Co., Limited 2019.