

## MODEL ZCH - QUADRATURE OUTPUT ROTARY PULSE GENERATOR MODEL ZFH and ZGH - QUADRATURE OUTPUT LENGTH SENSORS (Replaces MODELS RPGQ, LSQS and LSQD respectively)

- 100, 200 & 500 PULSES PER REVOLUTION
- QUADRATURE CURRENT SINKING OUTPUTS TO 50 KHz  
 For position measurement, bi-directional counting and systems with mechanical backlash
- SEALED PRECISION BALL BEARINGS
- RUGGED CAST ALUMINUM HOUSING
- 3/8" DIA. STAINLESS STEEL SHAFT
- WIDE INPUT SUPPLY VOLTAGE RANGE & LOW CURRENT OPERATION
- VARIOUS CABLE LENGTHS AVAILABLE



### DESCRIPTION

The units are rugged, incremental encoders that convert shaft rotation into a current sinking pulse train.

Internally, a single L.E.D. light source and a photologic sensor in conjunction with a shaft-mounted, durable, metal-etched encoder disc, provides signal accuracy and reliability to 50 KHz. The DC input power supply requirement is a versatile +8 to +28 VDC, and is reverse polarity protected. The NPN Open Collector Transistor Output is current limited to 40 mA and is compatible with most RLC counters, rate indicators, controllers and accessories.

All units are packaged in a rugged cast aluminum housing with a gasketed, rear aluminum cover. The 3/8" (9.53 mm) diameter heavy duty stainless steel shaft and sealed, lifetime-lubricated precision ball bearings are preloaded for minimum end play and rated for continuous use up to 6000 RPM. They are designed to meet NEMA 13/IP54 environmental requirements. All units are supplied with 10 feet (3M) of PVC jacketed 3-wire, 22 AWG cable with stranded shield wire and 100% foil shield coverage.

### ROTARY PULSE GENERATOR

The ZCH can be direct-coupled to a machine shaft by means of a flexible bellows, spring or rubber sleeve type coupler, etc., that allows for axial and radial misalignment. They can also be coupled with instrument timing belts and pulleys or gears. The housing may be rigidly face-mounted with the 4, #8-32 threaded holes. The 3-wire shielded cable exits through a cord connector.

### LENGTH SENSOR

The length sensors are available in both Single Ended Shaft (ZFH) and Double Ended Shaft (ZGH) versions, both of which include a Stainless Steel Handle Tube for mounting and 10 feet (3.05 M) of 3-wire shielded cable. When mounted to a Length Sensor Hinge Clamp Assembly (See Model LSAHC001) and coupled with one or two Measuring Wheels (See Measuring Wheels), a low cost, versatile and highly accurate length measurement system can be configured.

### LENGTH SENSOR MEASUREMENT ACCURACY

Factors which affect measurement accuracy include Measuring Wheel accuracy and wear, and material conditions. Ideally, materials which are hard, thin and strong provide good readings. Conversely, soft, thick and elastic materials can present problems in obtaining true readings. Count or Rate Indicators with "input scaling" can compensate for Measuring Wheel wear and material elasticity and compliance errors. In addition, English/Metric conversions may also be accomplished.

### LENGTH SENSOR ACCESSORIES

The Length Sensor Hinge Clamp Assembly provides an easy method for attachment & mounting the Length Sensors and LSCB1 Conversion Bracket. The removable top on the solid aluminum LSAHC mounting block allows quick installation of the Length Sensor handle tube and provides secure clamping retention. The mounting block steel shaft pivots freely in oil impregnated sintered bronze bushings, and aluminum right angle brackets allow mounting the assembly via clearance holes for 1/4" (6.35 mm) dia. bolts (See LSAHC Dimensions & Mounting).

### Open Collector Output Wiring

The ZCH, ZFH, and ZGH series of sensors have open collector outputs. An open collector output brings the uncommitted collector of the encoder switching device to the external world. Because the collector element is not associated with the sensor supply voltage, the sensor output collector may be "pulled up" to external voltages (40 VDC max.) different than the encoder supply voltage. NPN open collector outputs are current sinking devices. An output signal will not be generated unless a pull-up resistor is connected from the open-collector to the positive side of an external supply. The same supply can be used for powering the unit and for the pull-up resistor.

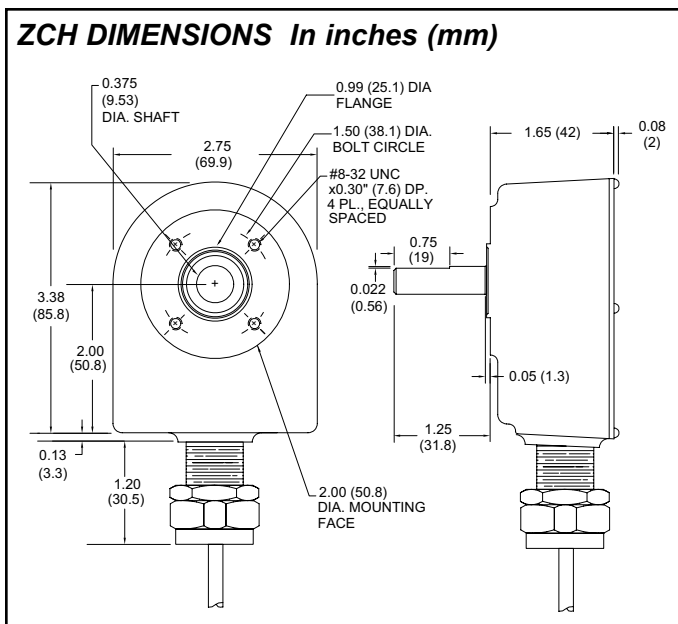

## ZFH DIMENSIONS In inches (mm)

This is the side view of the Model ZFH. All other dimensions (including the handle tube) are the same as the Model ZGH. See below.

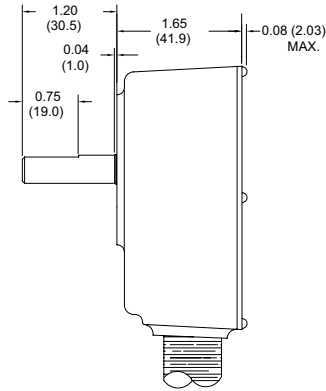

## ZGH DIMENSIONS In inches (mm)

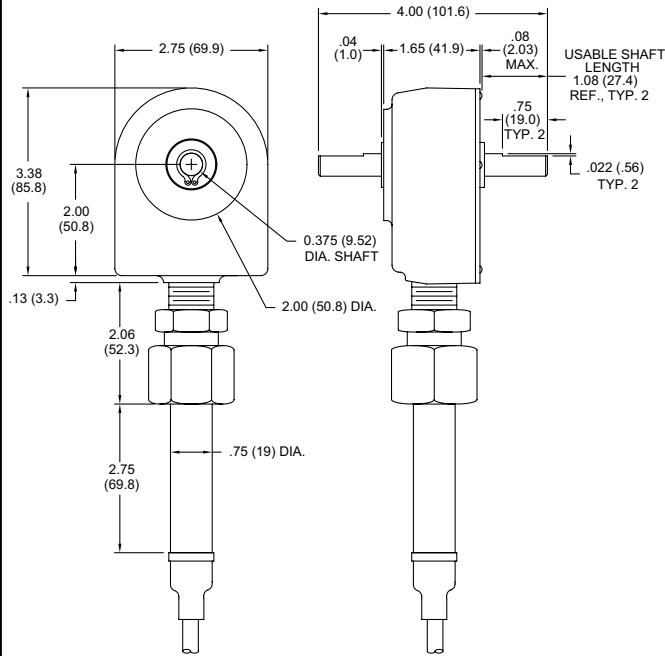

## SPECIFICATIONS

### ELECTRICAL SPECIFICATIONS

- SUPPLY VOLTAGE:** +8 to +28 VDC (including power supply ripple) @ 50 mA max. (30 mA typ.); Reverse polarity protected.
- OUTPUTS:** NPN Open Collector Transistor,  $V_{OH} = 30$  VDC max.,  $V_{OL} = 1$  V max @ 40 mA. Output current is limited to 40 mA. Incremental - Two square waves in quadrature with Channel A leading B for clockwise rotation.
- OUTPUT FREQUENCY:** Up to 50 KHz
- OUTPUT DUTY CYCLE:** Channel A & B: 50/50 nominal. (See Figure 1, Note 3)
- QUADRATURE OUTPUT PHASE:**  $90^\circ \pm 15^\circ$  (See Figure 1, Note 3)
- CABLE CONNECTIONS:** RED = +VDC; BLACK = Common; WHITE = Channel A Output; GREEN = Channel B Output.

### MECHANICAL SPECIFICATIONS

- MAXIMUM MECHANICAL SPEED:** 6000 RPM
- RADIAL SHAFT LOAD:** 15 lbs. max. (66.7N)
- AXIAL SHAFT LOAD:** 15 lbs. max. (66.7N)
- STARTING TORQUE:** 3 oz.-in. (21.2N-mm)
- MOMENT OF INERTIA:**  
Single Shaft =  $1.03 \times 10^{-4}$  oz. - in. - sec.<sup>2</sup> ( $7.30 \times 10^{-4}$  N - mm - sec.<sup>2</sup>)  
Dual Shaft =  $1.30 \times 10^{-4}$  oz. - in. - sec.<sup>2</sup> ( $9.21 \times 10^{-4}$  N - mm - sec.<sup>2</sup>)
- OPERATING TEMPERATURE:** 0°C to +70°C
- WEIGHT (LESS CABLE):**  
ZCH: 14.3 oz (406 g)  
ZFH: 22.0 oz (623 g)  
ZGH: 22.7 oz (643 g)

## EQUIVALENT CIRCUIT & CONNECTIONS

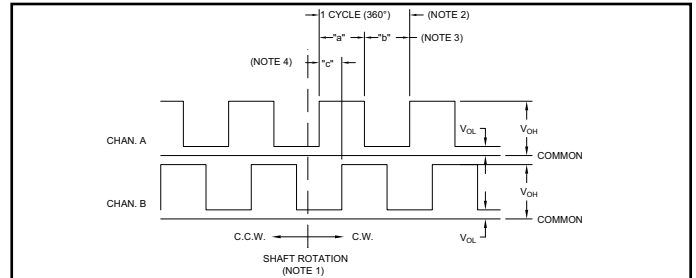
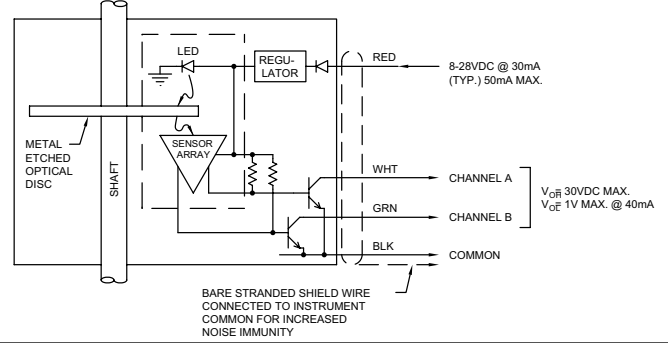

### NOTES:

- Channel A leads Channel B for clockwise shaft rotation when viewed from housing front. Conversely, Channel B leads Channel A for Counterclockwise shaft rotation.
- The number of lines on the optical disc determines the Pulses Per Revolution (PPR).
- Duty Cycle is the relationship of output "High" time, "a", to output "Low" time, "b", and is expressed as a High/Low percentage ratio, i.e. ...% High time =  $a/(a+b) \times 100$ ; % Low time =  $b/(a+b) \times 100$ .
- Quadrature Phase "c" is specified as the lead or lag between Channel A & B in electrical degrees. Nominally  $90^\circ$  (1/4 cycle).

### LENGTH SENSOR MOUNTING CONSIDERATION

- Length Sensors should be mounted so measuring wheel(s) contact ribbon, strip or web as it passes over a roller. As an alternative, wheel(s) can be driven by roller surface next to material being measured.
- Note: The weight at the Length Sensor unit provides sufficient traction for accurate operation when mounted, with arm angle from horizontal not exceeding  $\pm 30^\circ$ .
- Tension on signal cable can cause wheel(s) to lift. Make sure cable is clamped to machine frame near the unit and allow slack.

## ORDERING INFORMATION

MODEL NO.	DESCRIPTION	PPR	PART NUMBER
ZCH	Rotary Pulse Generator (Replaces RPGQ)	100	ZCH0100C
		200	ZCH0200C
		500	ZCH0500C
ZFH	Length Sensor Single Shaft (Replaces LSQS)	100	ZFH0100C
		200	ZFH0200C
		500	ZFH0500C
ZGH	Length Sensor Double Shaft (Replaces LSQD)	100	ZGH0100C
		200	ZGH0200C
		500	ZGH0500C
RPGFC	Flexible Coupling (1" Length) 0.250" - 0.375"	--	RPGFC002
	Flexible Coupling (1" Length) 0.375" - 0.375"	--	RPGFC003
	Flexible Coupling (1" Length) 0.375" - 0.500"	--	RPGFC004
	Flexible Coupling (1" Length) 0.375" - 6 mm	--	RPGFC006

\* 25 and 50 foot cable versions available. Consult factory for details.

## LENGTH SENSOR ACCESSORIES

### SEPARATE LENGTH MEASURING WHEELS - DIMENSIONS In Inches (mm)

WHEEL CODE <b>OR</b>	WHEEL CODE <b>OF</b>	WHEEL CODE <b>OK</b>
<p>Round Section Replaceable Tire .210" Section Dia. Black Neoprene</p> <p>8-32 UNF Set Screw</p> <p>.376" (9.6) Bore +.0011" -.0000"</p> <p>Cast Alum.</p> <p>3/8" (9.5)</p> <p><b>FOR USE ON: Metal, paper, foil, film and hard plastics. Line contact on material being measured, convenient when available measuring track is narrow or for measuring on end of roller beside passing material.</b></p> <p>Max. Speed: 600 RPM</p> <p><b>FOR USE ON: Soft, smooth</b></p>	<p>Tan, Smooth Polyurethane Tread</p> <p>10-32 UNF Set Screw</p> <p>.376" (9.6) Bore +.0011" -.0000"</p> <p>Cast Alum.</p> <p>1" (25.4)</p> <p><b>materials such as soft paper, matting, cardboard, fine weave textiles. Broad wheel tread minimizes contact pressure and tan polyurethane tread minimizes marking.</b></p> <p>Max. Speed: 600 RPM</p> <p>Balanced version of 1ft. circumference available. Balanced to ANSI S2.19-1989 Quality Grade 6.3 @ 3000 RPM.</p> <p><b>FOR USE ON: Rubber,</b></p>	<p>Diamond Knurled Aluminum Tread</p> <p>10-32 UNF Set Screw</p> <p>.376" (9.6) Bore +.0011" -.0000"</p> <p>Cast Alum.</p> <p>1" (25.4)</p> <p><b>coarse weave fabrics, rough wood surfaces, foam, insulation.</b></p> <p>Max. Speed: 600 RPM</p> <p>Balanced version of 1ft. circumference available. Balanced to ANSI S2.19-1989 Quality Grade 6.3 @ 3000 RPM.</p> <p style="text-align: right;"><b>SELECTING</b></p>

### APPROPRIATE WHEEL SIZE & PPR (Pulses Per Rev.) OF ROTARY PULSE GENERATOR

When the desired output of a length sensor and wheel combination is either in inches, feet, yards, or meters selection of the proper combination is relatively straight forward. For example, with a 1-foot wheel circumference, a 1 PPR Rotary Pulse Generator will deliver 1 pulse/ft, 12 PPR would deliver 12 pulses/ft (1 pulse/inch); 100 PPR would yield 100 pulses/ft; and 120 PPR would permit measuring to 1/10th of an inch (1/120th of a foot).

### WHEELS & REPLACEMENT TIRES FOR CODE OR WHEELS

#### ORDERING INFORMATION

WHEEL CODE	CIRCUMFERENCE	TOLERANCE	PART NUMBER
<b>OR</b>	1 foot (1/3 yd)	±0.40%	WF1000OR
<b>OF</b>	1 foot (1/3 yd)	±0.35%	WF1000OF
<b>BF</b> (Balanced)	1 foot (1/3 yd)	±0.40%	WF1000BF

WHEEL CODE	CIRCUMFERENCE	TOLERANCE	PART NUMBER
<b>OK</b>	1 foot (1/3 yd)	±0.35%	WF1000OK
<b>BK</b> (Balanced)	1 foot (1/3 yd)	±0.35%	WF1000BK
Replacement Tires for <b>OR</b> Wheels	1 foot (1/3 yd)		TORF1000

*Note: After installation of measuring wheels, ensure guards, shields or other devices are in place to protect personnel from rotating equipment.*

# MODEL LSAHC - LENGTH SENSOR HINGE CLAMP ASSEMBLY

The Length Sensor Hinge Clamp Assembly provides an easy method for attachment and mounting of the length sensors and LSCB1 Conversion Bracket. The removable top on the solid zinc LSAHC mounting block allows quick installation of the Length Sensor handle tube and provides secure clamping retention. The mounting block pivots freely in zinc right angle brackets to allow mounting the assembly via clearance holes for 1/4" dia. bolts.

The lock washers must be used as indicated (between the bolt head and the top clamp piece). Assemble the top clamp piece as follows.

1. Tighten both bolts so that the top clamp half draws down evenly on the sensor tube.
2. Tighten the bolts until both lock washers are flat.
3. Then turn each bolt an additional 1/2 to 3/4 turn.

## DIMENSIONS In inches (mm)

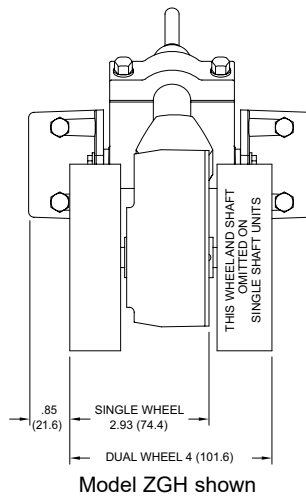
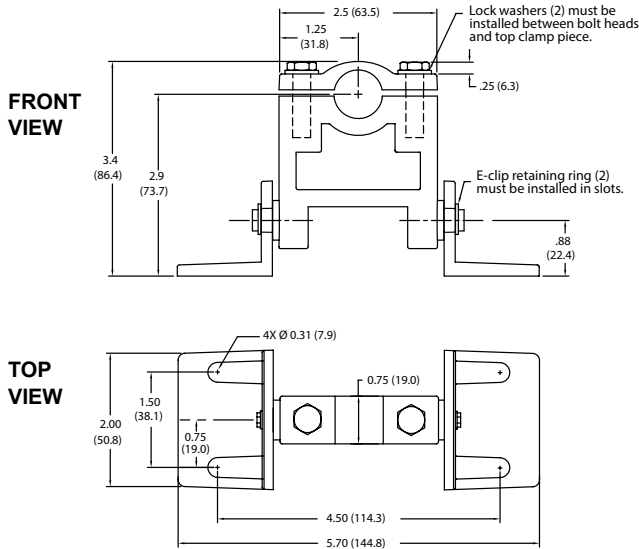

**CAUTION:** Downward tension on signal cable can cause wheel(s) to lift. Make sure cable is clamped to machine frame near encoder and allow slack.

**NOTE:** The weight at the Length Sensor unit provides sufficient traction for accurate operation when mounted as shown, with arm angle from horizontal not exceeding ±30°, and with hinge clamp toward the far extreme of the extension arm.

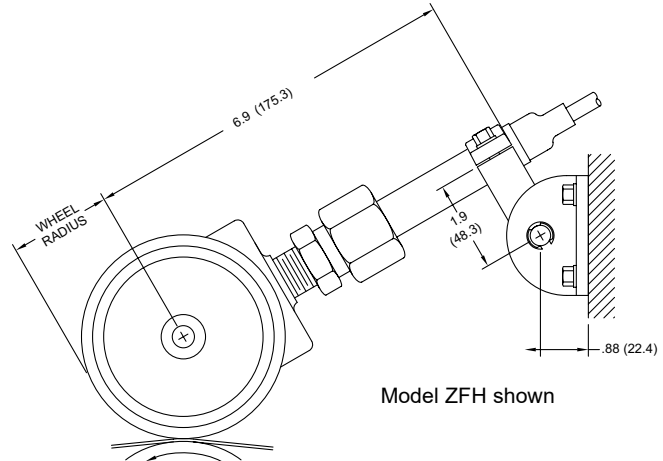

Length Sensors should be mounted so measuring wheel(s) contact ribbon, strip or web as it passes over a roller. As an alternative, wheel(s) can be driven by roller surface next to material being measured.

## ORDERING INFORMATION

MODEL NO.	DESCRIPTION	PART NUMBER
LSAHC	Length Sensor Hinge Clamp Assembly	LSAHC001

## LIMITED WARRANTY

(a) Red Lion Controls Inc. (the "Company") warrants that all Products shall be free from defects in material and workmanship under normal use for the period of time provided in "Statement of Warranty Periods" (available at [www.redlion.net](http://www.redlion.net)) current at the time of shipment of the Products (the "Warranty Period"). **EXCEPT FOR THE ABOVE-STATED WARRANTY, COMPANY MAKES NO WARRANTY WHATSOEVER WITH RESPECT TO THE PRODUCTS, INCLUDING ANY (A) WARRANTY OF MERCHANTABILITY; (B) WARRANTY OF FITNESS FOR A PARTICULAR PURPOSE; OR (C) WARRANTY AGAINST INFRINGEMENT OF INTELLECTUAL PROPERTY RIGHTS OF A THIRD PARTY; WHETHER EXPRESS OR IMPLIED BY LAW, COURSE OF DEALING, COURSE OF PERFORMANCE, USAGE OF TRADE OR OTHERWISE.** Customer shall be responsible for determining that a Product is suitable for Customer's use and that such use complies with any applicable local, state or federal law.

(b) The Company shall not be liable for a breach of the warranty set forth in paragraph (a) if (i) the defect is a result of Customer's failure to store, install, commission or maintain the Product according to specifications; (ii) Customer alters or repairs such Product without the prior written consent of Company.

(c) Subject to paragraph (b), with respect to any such Product during the Warranty Period, Company shall, in its sole discretion, either (i) repair or replace the Product; or (ii) credit or refund the price of Product provided that, if Company so requests, Customer shall, at Company's expense, return such Product to Company.

(d) **THE REMEDIES SET FORTH IN PARAGRAPH (c) SHALL BE THE CUSTOMER'S SOLE AND EXCLUSIVE REMEDY AND COMPANY'S ENTIRE LIABILITY FOR ANY BREACH OF THE LIMITED WARRANTY SET FORTH IN PARAGRAPH (a).**

**BY INSTALLING THIS PRODUCT, YOU AGREE TO THE TERMS OF THIS WARRANTY, AS WELL AS ALL OTHER DISCLAIMERS AND WARRANTIES IN THIS DOCUMENT.**