

Mechanical Dimensions: Inches [mm]

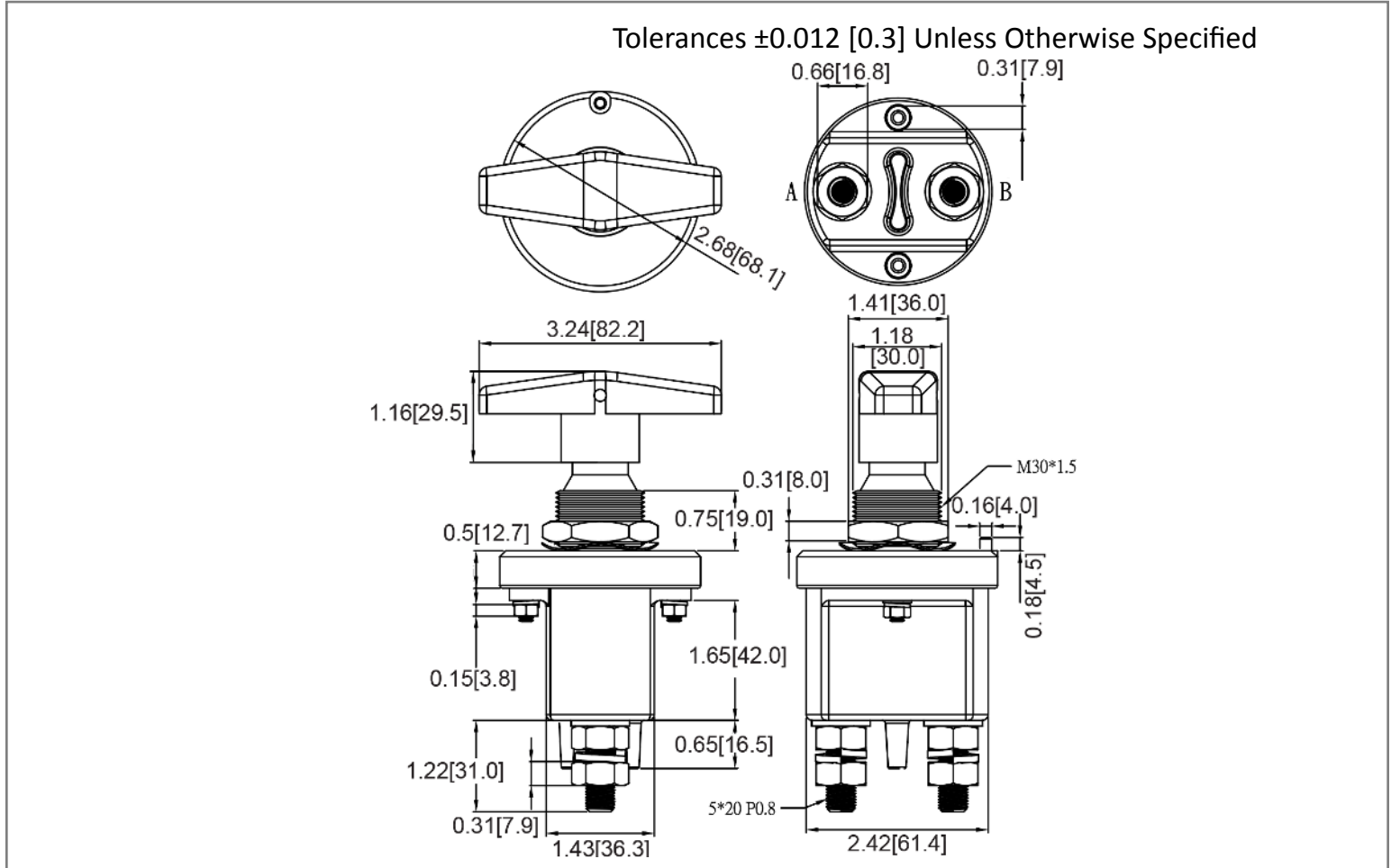

Mounting Hole

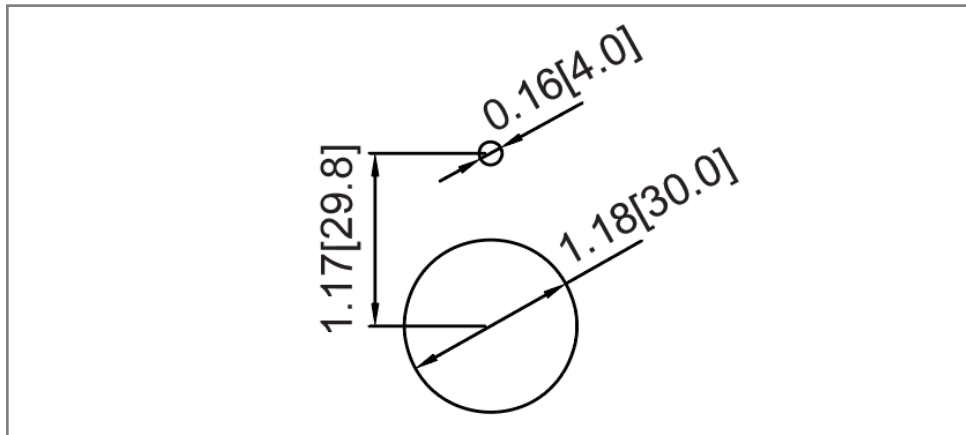

Circuit Diagram

SPST: Does not disconnect alternator or generator field circuit.

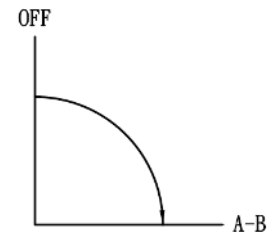

Electrical Specifications

Continuous Rating	500A 12VDC, 300A 24VDC
Intermittent Rating	2000A for 5secs intervals
Insulation Resistance	DC 500V 100M ohm Min
Dielectric Strength	AC 1000V 1 minute
Operation Temperature	-40°C ~ 85°C

Material Specifications

Vibration Resistance	3G (50-2000Hz)
Shock Resistance	6G, 11msec
	IP66 / IEC529
	includes Lock-Out Bracket

Rev **Date of issue** **Revision Notes**

Designed **Approved**

A	03-16-2020	Initial Drawing	RC	OF
---	------------	-----------------	----	----