

SDFE-4/2/1

Symmetric DSL Front End, 4/2/1
Channel

SDFE-4, PEF 24624 E

SDFE-2, PEF 22624 E

SDFE-1, PEF 21624 E



The SDFE-4/2/1 are the latest members of Infineon's 2nd generation SOCRATES® family of SHDSL transceivers designed for pure TDM applications.

The SDFE-4/2/1 features full compliance with the ETSI TS 101524 and the ITU G.991.2 (G.SHDSL/G.SHDSL.bis) standards. Advanced system functionality and cost saving features continue to provide significant low BOM advantages in the SOCRATES tradition.

These features, in combination with an unprecedented power consumption of approximately 500 mW per channel, and a very small footprint, make the SDFE-4/2 excellent solutions for remote powered repeater designs.

Applications

- ISDN primary rate access replacement
- SHDSL repeater/regenerator
- Digital Loop Carrier (DLC) Systems
- Extended range full and fractional E1/T1
- RITL and WLL systems
- Wireless infrastructure
- SDH and SONET termination
- TU-12 transport
- Leased line services
- PBX trunk lines

Features

- Fully integrated 4/2/1 channel transceiver solution, including DSP, microcontroller, analog front end (AFE), line driver and memory, in a single integrated chip
- Support of payload data rates from 144 kbit/s up to 6.392 kbit/s with 8 kbit/s granularity (exceeding G.SHDSL.bis)
- M-pair functionality integrated
- Tunable hybrid for optimal loop adaptation and reach
- Only a few external passive components required

Loop Interface

- Line probing according ITU-T G.991.2 (2004)
- Flexible setting of PSD shaping
- Highly sophisticated TC-PAM line coding
- Programmable framer
- Supported TDM clocks: 1.544 MHz, 2.048 MHz, 2.312 MHz, 4.096 MHz, 8.192 MHz, 16.384 MHz

EOC

- 4/2/1 integrated HDLC controllers for EOC handling (one per channel)
- 128-byte FIFO for transmit and receive direction per channel

Customer Interface

- Universal TDM interface
- Bit-serial interface

Modes

- Line termination unit LTU (STU-C)
- Network termination unit NTU (STU-R)
- Regenerator unit COT/RT (SRU-C/R)

Physical Characteristics

- Only two power supplies: 3.3 V, 1.8 V
- Power consumption approximately 500 mW per channel
- Temperature range -40°C to +85°C
- Package P-LBGA-324 (19 mm x 19 mm)
- SDFE-4/2/1 are pin and software compatible

www.infineon.com/products

Wireline Communications



Never stop thinking.

SDFE 4/2/1 PHY Block Diagram

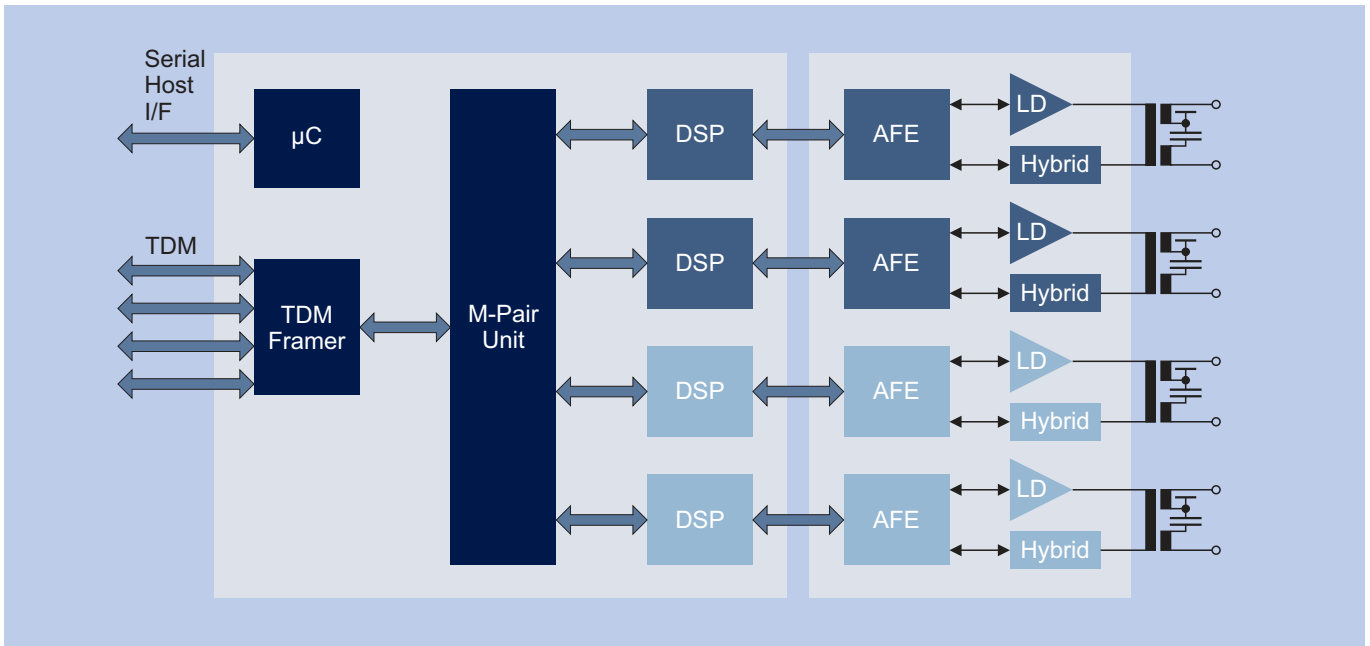

Ordering Information

SDFE-4/2/1

Product Sales Code	Product	Description	Package
PEF24624E	SDFE-4	4-Channel Symmetric DSL Front End	P-LBGA-324
PEF22624E	SDFE-2	2-Channel Symmetric DSL Front End	P-LBGA-324
PEF21624E	SDFE-1	1-Channel Symmetric DSL Front End	P-LBGA-324

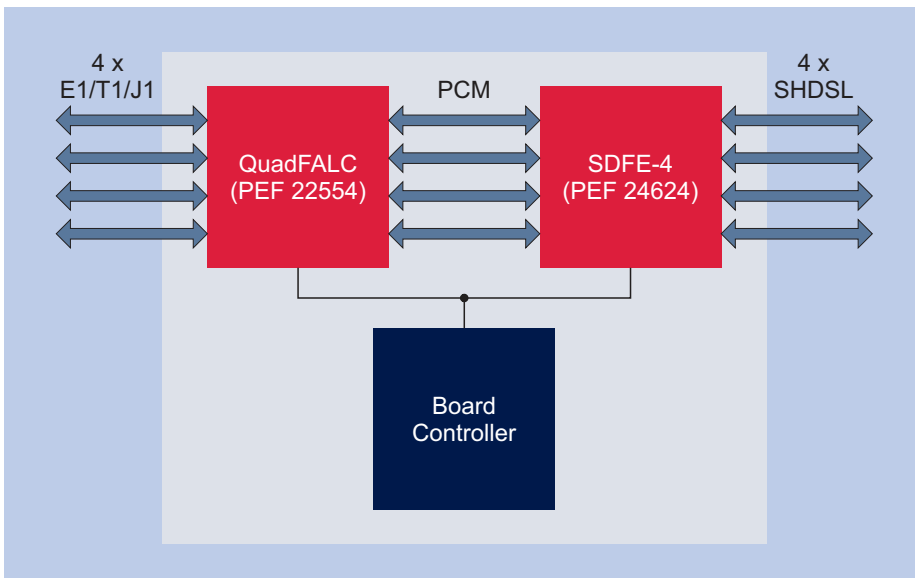

E1/T1 Replacement Application Example

How to reach us:
<http://www.infineon.com>

Published by
 Infineon Technologies AG,
 St.-Martin-Strasse 53,
 81669 München

© Infineon Technologies AG 2004.
 All Rights Reserved.

Template: pb_tmplt.fm/4

Attention please!

The information herein is given to describe certain components and shall not be considered as a guarantee of characteristics. Terms of delivery and rights to technical change reserved. We hereby disclaim any and all warranties, including but not limited to warranties of non-infringement, regarding circuits, descriptions and charts stated herein.

Information

For further information on technology, delivery terms and conditions and prices please contact your nearest Infineon Technologies Office.

Warnings

Due to technical requirements components may contain dangerous substances. For information on the types in question please contact your nearest Infineon Technologies Office.

Infineon Technologies Components may only be used in life-support devices or systems with the express written approval of Infineon Technologies, if a failure of such components can reasonably be expected to cause the failure of that life-support device or system, or to affect the safety or effectiveness of that device or system. Life support devices or systems are intended to be implanted in the human body, or to support and/or maintain and sustain and/or protect human life. If they fail, it is reasonable to assume that the health of the user or other persons may be endangered.

Ordering No. B115-H8424-X-X-7600
 Printed in Germany
 PS 06041. nb