

FEATURES

- 6.0 GHz bandwidth
- 2.7 V to 3.3 V power supply
- Separate charge pump supply (V_P) allows extended tuning voltage in 3 V systems
- Programmable dual-modulus prescaler
8/9, 16/17, 32/33, 64/65
- Programmable charge pump currents
- Programmable antibacklash pulse width
- 3-wire serial interface
- Analog and digital lock detect
- Hardware and software power-down mode
- Support defense and aerospace applications (AQEC)
- Military temperature range (-55°C to $+125^{\circ}\text{C}$)
- Controlled manufacturing baseline
- One assembly/test site
- One fabrication site
- Product change notification
- Qualification data available upon request

APPLICATIONS

- Broadband wireless access
- Satellite systems
- Instrumentation
- Wireless LANS
- Base stations for wireless radios

GENERAL DESCRIPTION

The **ADF4106-EP** frequency synthesizer can be used to implement local oscillators in the up-conversion and down-conversion sections of wireless receivers and transmitters. It consists of a low noise, digital phase frequency detector (PFD), a precision charge pump, a programmable reference divider, programmable A counter and B counter, and a dual-modulus prescaler ($P/P + 1$). The A (6-bit) counter and B (13-bit) counter, in conjunction with the dual-modulus prescaler ($P/P + 1$), implement an N divider ($N = BP + A$). In addition, the 14-bit reference counter (R counter) allows selectable REF_{IN} frequencies at the PFD input. A complete phase-locked loop (PLL) can be implemented if the synthesizer is used with an external loop filter and voltage controlled oscillator (VCO). Its very high bandwidth means that frequency doublers can be eliminated in many high frequency systems, simplifying system architecture and reducing cost.

Additional application and technical information can be found in the **ADF4106** data sheet.

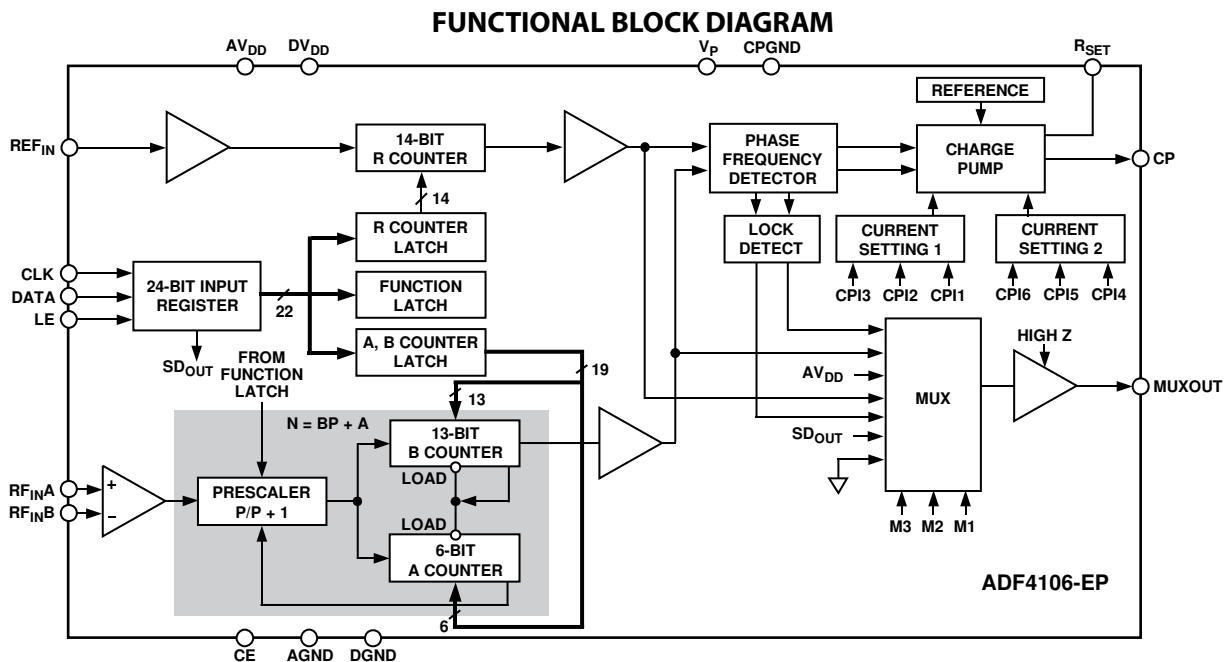

Figure 1.

Rev. D

[Document Feedback](#)

Information furnished by Analog Devices is believed to be accurate and reliable. However, no responsibility is assumed by Analog Devices for its use, nor for any infringements of patents or other rights of third parties that may result from its use. Specifications subject to change without notice. No license is granted by implication or otherwise under any patent or patent rights of Analog Devices. Trademarks and registered trademarks are the property of their respective owners.

TABLE OF CONTENTS

Features 1
 Applications 1
 General Description 1
 Functional Block Diagram 1
 Revision History 2
 Specifications 3
 Timing Characteristics 4
 Absolute Maximum Ratings 5

ESD Caution 5
 Pin Configurations and Function Descriptions 6
 Typical Performance Characteristics 7
 Printed Circuit Board (PCB) Design Guidelines for Chip Scale Package 9
 Outline Dimensions 10
 Ordering Guide 10

REVISION HISTORY

10/2018—Rev. C to Rev. D
 Change to Features Section 1
 Changes to Figure 6 7
 Changes to Ordering Guide 10

11/2014—Rev. B to Rev. C
 Change to Table 1 3
 Change to Table 2 4
 Changes to Table 3 5

8/2012—Rev. A to Rev. B
 Changes to Table 3 5
 Updated Outline Dimensions 10
 Changes to Ordering Guide 10

11/2010—Rev. 0 to Rev. A
 Changes to Figure 6 7
 Changes to Figure 11 8
 Changes to Ordering Guide 10

8/2010—Revision 0: Initial Version

SPECIFICATIONS

$AV_{DD} = DV_{DD} = 3\text{ V} \pm 10\%$, $AV_{DD} \leq V_P \leq 5.5\text{ V}$, $AGND = DGND = CPGND = 0\text{ V}$, $R_{SET} = 5.1\text{ k}\Omega$, dBm referred to $50\ \Omega$, $T_A = T_{MAX}$ to T_{MIN} , unless otherwise noted.

Table 1.

Parameter	S Version ¹	Unit	Test Conditions/Comments
RF CHARACTERISTICS			
RF Input Frequency (RF_{IN})	0.5/6.0	GHz min/max	For lower frequencies, ensure slew rate (SR) > 320 V/ μ s
RF Input Sensitivity	-10/0	dBm min/max	
Maximum Allowable Prescaler Output Frequency ²	300	MHz max	P = 8
	325	MHz	P = 16
REF_{IN} CHARACTERISTICS			
REF _{IN} Input Frequency	20/300	MHz min/max	For f < 20 MHz, ensure SR > 50 V/ μ s
REF _{IN} Input Sensitivity ³	0.8/ V_{DD}	V p-p min/max	Biased at $AV_{DD}/2^4$
REF _{IN} Input Capacitance	10	pF max	
REF _{IN} Input Current	± 100	μ A max	
PHASE DETECTOR			
Phase Detector Frequency ⁵	104	MHz max	ABP = 0, 0 (2.9 ns antibacklash pulse width)
CHARGE PUMP			
I_{CP} Sink/Source			
High Value	5	mA typ	With $R_{SET} = 5.1\text{ k}\Omega$
Low Value	625	μ A typ	
Absolute Accuracy	2.5	% typ	With $R_{SET} = 5.1\text{ k}\Omega$
R_{SET} Range	3.0/11	k Ω typ	
I_{CP} Three-State Leakage	2	nA max	1 nA typical; $T_A = 25^\circ\text{C}$
Sink and Source Current Matching	2	% typ	$0.5\text{ V} \leq V_{CP} \leq V_P - 0.5\text{ V}$
I_{CP} vs. V_{CP}	1.5	% typ	$0.5\text{ V} \leq V_{CP} \leq V_P - 0.5\text{ V}$
I_{CP} vs. Temperature	2	% typ	$V_{CP} = V_P/2$
LOGIC INPUTS			
V_{IH} , Input High Voltage	1.4	V min	
V_{IL} , Input Low Voltage	0.6	V max	
I_{INH} , I_{INL} , Input Current	± 1	μ A max	
C_{IN} , Input Capacitance	10	pF max	
LOGIC OUTPUTS			
V_{OH} , Output High Voltage	1.4	V min	Open-drain output chosen, 1 k Ω pull-up resistor to 1.8 V
	$V_{DD} - 0.4$	V min	CMOS output chosen
I_{OH}	100	μ A max	
V_{OL} , Output Low Voltage	0.4	V max	$I_{OL} = 500\ \mu\text{A}$
POWER SUPPLIES			
AV_{DD}	2.7/3.3	V min/V max	
DV_{DD}	AV_{DD}		
V_P	$AV_{DD}/5.5$	V min/V max	$AV_{DD} \leq V_P \leq 5.5\text{ V}$
I_{DD}^6 ($AI_{DD} + DI_{DD}$)	11	mA max	9.0 mA typical
I_{DD}^7 ($AI_{DD} + DI_{DD}$)	11.5	mA max	9.5 mA typical
I_{DD}^8 ($AI_{DD} + DI_{DD}$)	13	mA max	10.5 mA typical
I_P	0.4	mA max	$T_A = 25^\circ\text{C}$
Power-Down Mode ⁹ ($AI_{DD} + DI_{DD}$)	10	μ A typ	

Parameter	S Version ¹	Unit	Test Conditions/Comments
NOISE CHARACTERISTICS			
Normalized Phase Noise Floor (PN _{SYNTH}) ¹⁰	-223	dBc/Hz typ	PLL loop BW = 500 kHz
Normalized 1/f Noise (PN _{1/f}) ¹¹	-122	dBc/Hz typ	Measured at 10 kHz offset; normalized to 1 GHz
Phase Noise Performance ¹²			VCO output
900 MHz ¹³	-92.5	dBc/Hz typ	1 kHz offset and 200 kHz PFD frequency
5800 MHz ¹⁴	-76.5	dBc/Hz typ	1 kHz offset and 200 kHz PFD frequency
5800 MHz ¹⁵	-83.5	dBc/Hz typ	1 kHz offset and 1 MHz PFD frequency
Spurious Signals			
900 MHz ¹³	-90/-92	dBc typ	200 kHz/400 kHz and 200 kHz PFD frequency
5800 MHz ¹⁴	-65/-70	dBc typ	200 kHz/400 kHz and 200 kHz PFD frequency
5800 MHz ¹⁵	-70/-75	dBc typ	1 MHz/2 MHz and 1 MHz PFD frequency

¹ Operating temperature range is -55°C to +125°C.

² This is the maximum operating frequency of the CMOS counters. The prescaler value should be chosen to ensure that the RF input is divided down to a frequency that is less than this value.

³ AV_{DD} = DV_{DD} = 3 V.

⁴ AC coupling ensures AV_{DD}/2 bias.

⁵ Guaranteed by design. Sample tested to ensure compliance.

⁶ T_A = 25°C; AV_{DD} = DV_{DD} = 3 V; P = 16; RF_{IN} = 900 MHz.

⁷ T_A = 25°C; AV_{DD} = DV_{DD} = 3 V; P = 16; RF_{IN} = 2.0 GHz.

⁸ T_A = 25°C; AV_{DD} = DV_{DD} = 3 V; P = 32; RF_{IN} = 6.0 GHz.

⁹ T_A = 25°C; AV_{DD} = DV_{DD} = 3.3 V; R = 16383; A = 63; B = 891; P = 32; RF_{IN} = 6.0 GHz.

¹⁰ The synthesizer phase noise floor is estimated by measuring the in-band phase noise at the output of the VCO and subtracting 20 log N (where N is the N divider value) and 10 log F_{PFD}. PN_{SYNTH} = PN_{TOT} - 10 log F_{PFD} - 20 log N.

¹¹ The PLL phase noise is composed of 1/f (flicker) noise plus the normalized PLL noise floor. The formula for calculating the 1/f noise contribution at an RF frequency, f_{RF}, and at a frequency offset, f, is given by PN = P_{1/f} + 10log(10 kHz/f) + 20log(f_{RF}/1 GHz). Both the normalized phase noise floor and flicker noise are modeled in ADIsimPLL.

¹² The phase noise is measured with the EVAL-ADF4106-EB1 evaluation board and the Agilent E4440A spectrum analyzer. The spectrum analyzer provides the REF_{IN} for the synthesizer (f_{REFOUT} = 10 MHz at 0 dBm).

¹³ f_{REFIN} = 10 MHz; f_{PFD} = 200 kHz; offset frequency = 1 kHz; f_{RF} = 900 MHz; N = 4500; loop B/W = 20 kHz.

¹⁴ f_{REFIN} = 10 MHz; f_{PFD} = 200 kHz; offset frequency = 1 kHz; f_{RF} = 5800 MHz; N = 29,000; loop B/W = 20 kHz.

¹⁵ f_{REFIN} = 10 MHz; f_{PFD} = 1 MHz; offset frequency = 1 kHz; f_{RF} = 5800 MHz; N = 5800; loop B/W = 100 kHz.

TIMING CHARACTERISTICS

AV_{DD} = DV_{DD} = 3 V ± 10%, AV_{DD} ≤ V_P ≤ 5.5 V, AGND = DGND = CPGND = 0 V, R_{SET} = 5.1 kΩ, dBm referred to 50 Ω, T_A = T_{MAX} to T_{MIN}, unless otherwise noted.

Table 2.

Parameter	Limit ¹ (B Version)	Unit	Test Conditions/Comments
t ₁	10	ns min	DATA to CLOCK Setup Time
t ₂	10	ns min	DATA to CLOCK Hold Time
t ₃	25	ns min	CLOCK High Duration
t ₄	25	ns min	CLOCK Low Duration
t ₅	10	ns min	CLOCK to LE Setup Time
t ₆	20	ns min	LE Pulse Width

¹ Operating temperature range (S Version) is -55°C to +125°C.

Timing Diagram

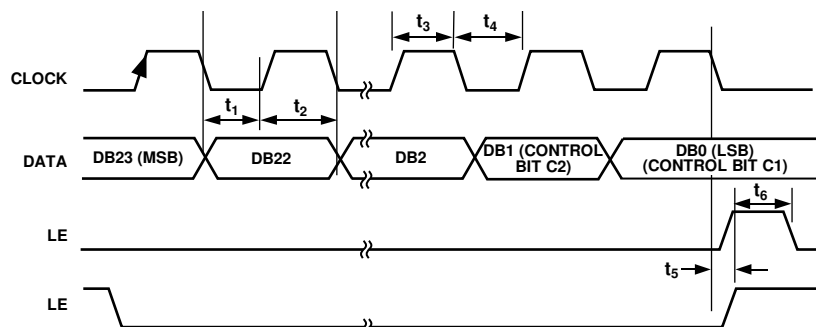

Figure 2. Timing Diagram

ABSOLUTE MAXIMUM RATINGS

T_A = 25°C, unless otherwise noted.

Table 3.

Parameter	Rating
AV _{DD} to GND ¹	−0.3 V to + 3.6 V
AV _{DD} to DV _{DD}	−0.3 V to + 0.3 V
V _P to GND	−0.3 V to + 5.8 V
V _P to AV _{DD}	−0.3 V to + 5.8 V
Digital I/O Voltage to GND	−0.3 V to V _{DD} + 0.3 V
Analog I/O Voltage to GND	−0.3 V to V _P + 0.3 V
REF _{IN} , RF _{IN} A, RF _{IN} B to GND	−0.3 V to V _{DD} + 0.3 V
RF _{IN} A to RF _{IN} B	±320 mV
Operating Temperature Range	
Industrial (S Version)	−55°C to +125°C
Storage Temperature Range	−65°C to +125°C
Maximum Junction Temperature	150°C
θ _{JA} Thermal Impedance	
16-Lead TSSOP	112°C/W
20-Lead LFCSP (Paddle Soldered)	30.4°C/W
Reflow Soldering	
Peak Temperature	260°C
Time at Peak Temperature	40 sec
Transistor Count	
CMOS	6425
Bipolar	303

¹GND = AGND = DGND = 0 V.

Stresses at or above those listed under Absolute Maximum Ratings may cause permanent damage to the product. This is a stress rating only; functional operation of the product at these or any other conditions above those indicated in the operational section of this specification is not implied. Operation beyond the maximum operating conditions for extended periods may affect product reliability.

This device is a high performance RF integrated circuit with an ESD rating of <2 kV, and it is ESD sensitive. Take proper precautions for handling and assembly.

ESD CAUTION



ESD (electrostatic discharge) sensitive device. Charged devices and circuit boards can discharge without detection. Although this product features patented or proprietary protection circuitry, damage may occur on devices subjected to high energy ESD. Therefore, proper ESD precautions should be taken to avoid performance degradation or loss of functionality.

PIN CONFIGURATIONS AND FUNCTION DESCRIPTIONS

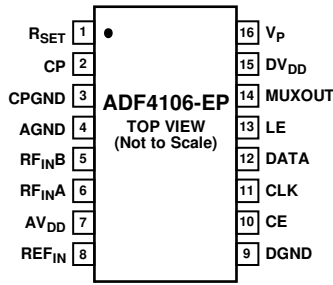

NOTES:
1. TRANSISTOR COUNT 6425 (CMOS),
303 (BIPOLAR).

09272-003

Figure 3. 16-Lead TSSOP Pin Configuration

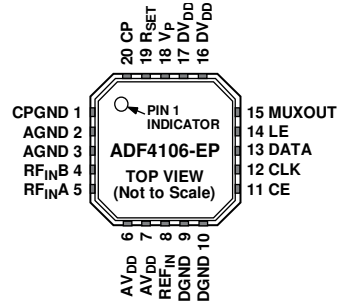

NOTES
1. TRANSISTOR COUNT 6425 (CMOS),
303 (BIPOLAR).
2. THE EXPOSED PAD MUST BE
CONNECTED TO AGND.

09272-004

Figure 4. 20-Lead LFCSP Pin Configuration

Table 4. Pin Function Descriptions

Pin No. TSSOP	Pin No. LFCSP	Mnemonic	Description
1	19	R _{SET}	Connecting a resistor between this pin and CPGND sets the maximum charge pump output current. The nominal voltage potential at the R _{SET} pin is 0.66 V. The relationship between I _{CP MAX} and R _{SET} is $I_{CP\ MAX} = \frac{25.5}{R_{SET}}$ So, with R _{SET} = 5.1 kΩ, I _{CP MAX} = 5 mA.
2	20	CP	Charge Pump Output. When enabled, this provides ±I _{CP} to the external loop filter, which in turn drives the external VCO.
3	1	CPGND	Charge Pump Ground. This is the ground return path for the charge pump.
4	2, 3	AGND	Analog Ground. This is the ground return path of the prescaler.
5	4	RF _{INB}	Complementary Input to the RF Prescaler. This point must be decoupled to the ground plane with a small bypass capacitor, typically 100 pF.
6	5	RF _{INA}	Input to the RF Prescaler. This small signal input is ac-coupled to the external VCO.
7	6, 7	AV _{DD}	Analog Power Supply. This can range from 2.7 V to 3.3 V. Decoupling capacitors to the analog ground plane should be placed as close as possible to this pin. AV _{DD} must be the same value as DV _{DD} .
8	8	REF _{IN}	Reference Input. This is a CMOS input with a nominal threshold of V _{DD} /2 and a dc equivalent input resistance of 100 kΩ. This input can be driven from a TTL or CMOS crystal oscillator or it can be ac-coupled.
9	9, 10	DGND	Digital Ground.
10	11	CE	Chip Enable. A logic low on this pin powers down the device and puts the charge pump output into three-state mode. Taking the pin high powers up the device, depending on the status of the power-down bit, F2.
11	12	CLK	Serial Clock Input. This serial clock is used to clock in the serial data to the registers. The data is latched into the 24-bit shift register on the CLK rising edge. This input is a high impedance CMOS input.
12	13	DATA	Serial Data Input. The serial data is loaded MSB first with the two LSBs being the control bits. This input is a high impedance CMOS input.
13	14	LE	Load Enable, CMOS Input. When LE goes high, the data stored in the shift registers is loaded into one of the four latches with the latch being selected using the control bits.
14	15	MUXOUT	This multiplexer output allows either the lock detect, the scaled RF, or the scaled reference frequency to be accessed externally.
15	16, 17	DV _{DD}	Digital Power Supply. This can range from 2.7 V to 3.3 V. Decoupling capacitors to the digital ground plane should be placed as close as possible to this pin. DV _{DD} must be the same value as AV _{DD} .
16	18	V _P	Charge Pump Power Supply. This should be greater than or equal to V _{DD} . In systems where V _{DD} is 3 V, it can be set to 5.5 V and used to drive a VCO with a tuning range of up to 5 V.
Not applicable		EP	Exposed Pad. The exposed pad must be connected to AGND.

TYPICAL PERFORMANCE CHARACTERISTICS

FREQ UNIT	GHz	KEYWORD	R
PARAM TYPE	S	IMPEDANCE	50Ω
DATA FORMAT	MA		
FREQ	MAGS11	ANGS11	FREQ MAGS11 ANGS11
0.500	0.89148	-17.2820	3.300 0.42777 -102.748
0.600	0.88133	-20.6919	3.400 0.42859 -107.167
0.700	0.87152	-24.5386	3.500 0.43365 -111.883
0.800	0.85855	-27.3228	3.600 0.43849 -117.548
0.900	0.84911	-31.0698	3.700 0.44475 -123.856
1.000	0.83512	-34.8623	3.800 0.44800 -130.399
1.100	0.82374	-38.5574	3.900 0.45223 -136.744
1.200	0.80871	-41.9093	4.000 0.45555 -142.766
1.300	0.79176	-45.6990	4.100 0.45313 -149.269
1.400	0.77205	-49.4185	4.200 0.45622 -154.884
1.500	0.75696	-52.8898	4.300 0.45555 -159.680
1.600	0.74234	-56.2923	4.400 0.46108 -164.916
1.700	0.72239	-60.2584	4.500 0.45325 -168.452
1.800	0.69419	-63.1446	4.600 0.45054 -173.462
1.900	0.67288	-65.6464	4.700 0.45200 -176.697
2.000	0.66227	-68.0742	4.800 0.45043 178.824
2.100	0.64758	-71.3530	4.900 0.45282 174.947
2.200	0.62454	-75.5658	5.000 0.44287 170.237
2.300	0.59466	-79.6404	5.100 0.44909 166.617
2.400	0.55932	-82.8246	5.200 0.44294 162.786
2.500	0.52256	-85.2795	5.300 0.44558 158.766
2.600	0.48754	-85.6298	5.400 0.45417 153.195
2.700	0.46411	-86.1854	5.500 0.46038 147.721
2.800	0.45776	-86.4997	5.600 0.47128 139.760
2.900	0.44859	-88.8080	5.700 0.47439 132.657
3.000	0.44588	-91.9737	5.800 0.48604 125.782
3.100	0.43810	-95.4087	5.900 0.50637 121.110
3.200	0.43269	-99.1282	6.000 0.52172 115.400

Figure 5. S-Parameter Data for the RF Input

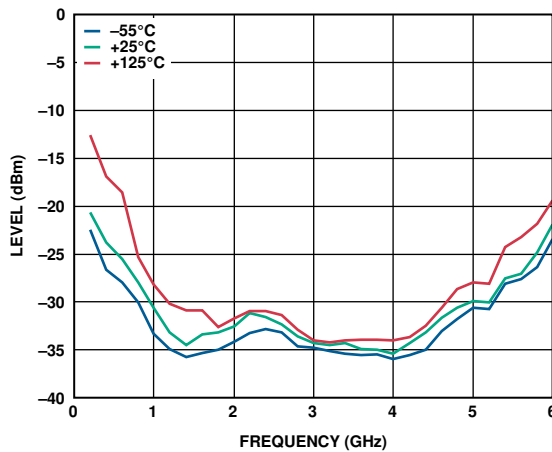

Figure 6. Input Sensitivity

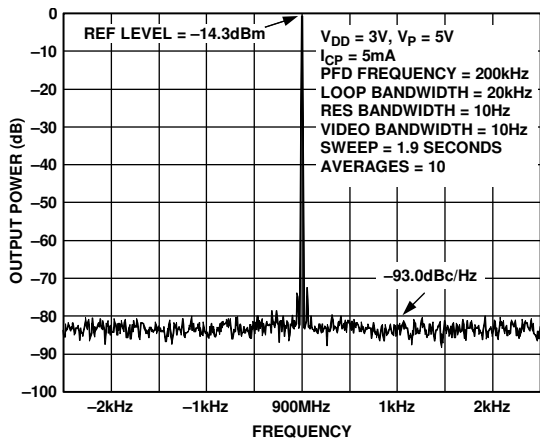

Figure 7. Phase Noise (900 MHz, 200 kHz, and 20 kHz)

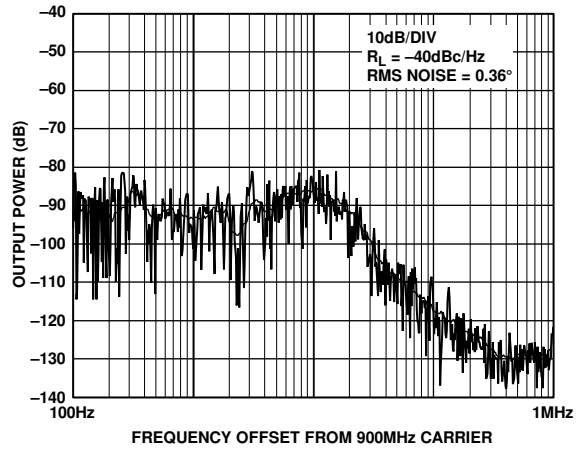

Figure 8. Integrated Phase Noise (900 MHz, 200 kHz, and 20 kHz)

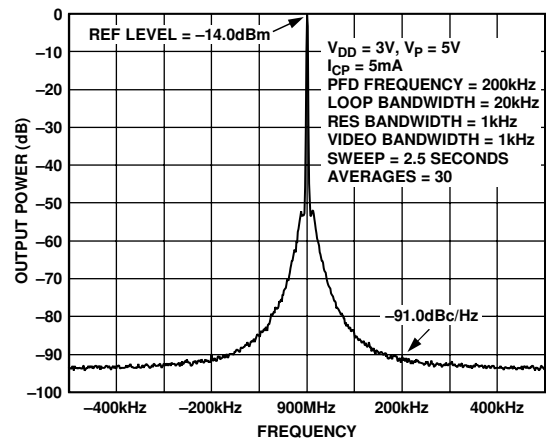

Figure 9. Reference Spurs (900 MHz, 200 kHz, and 20 kHz)

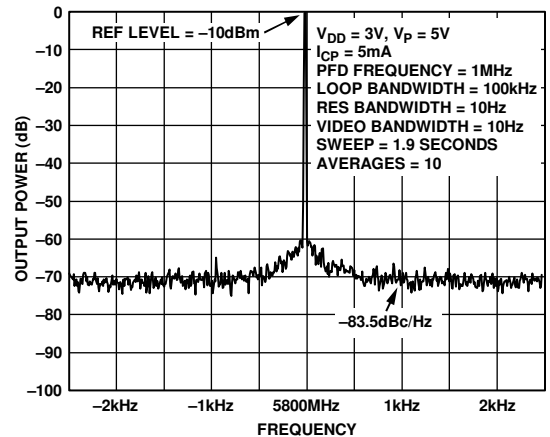

Figure 10. Phase Noise (5.8 GHz, 1 MHz, and 100 kHz)

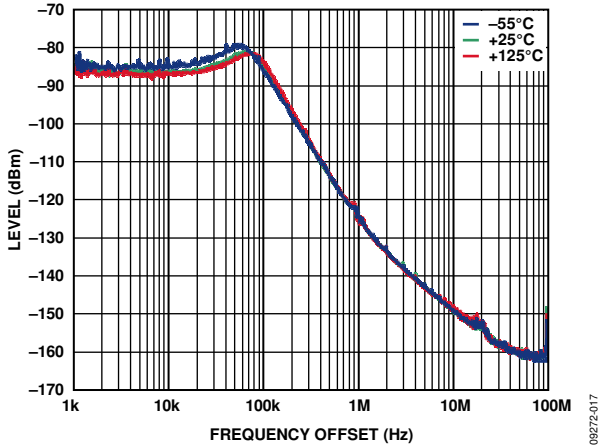

Figure 11. Integrated Phase Noise (5.8 GHz, 1 MHz, and 100 kHz)

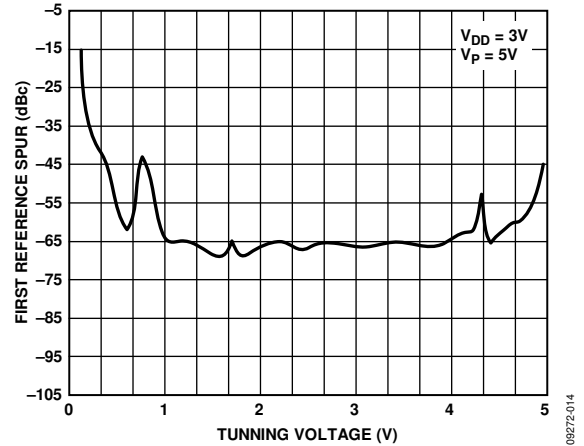

Figure 14. Reference Spurs vs. V_{TUNE} (5.8 GHz, 1 MHz, and 100 kHz)

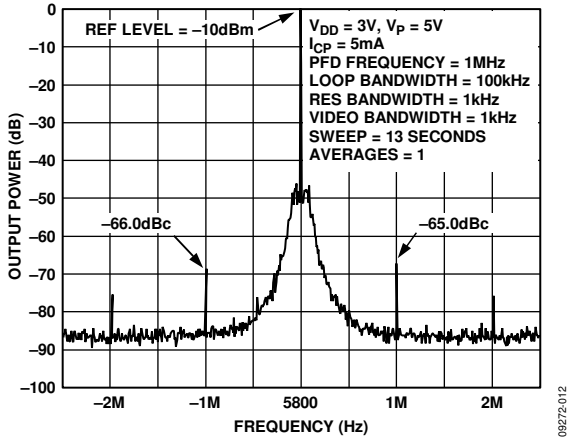

Figure 12. Reference Spurs (5.8 GHz, 1 MHz, and 100 kHz)

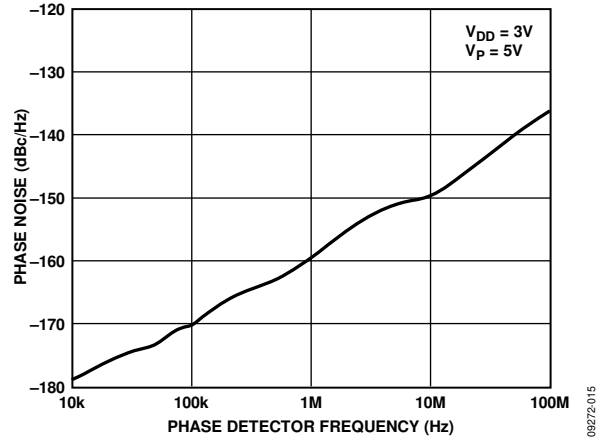

Figure 15. Phase Noise (Referred to CP Output) vs. PFD Frequency

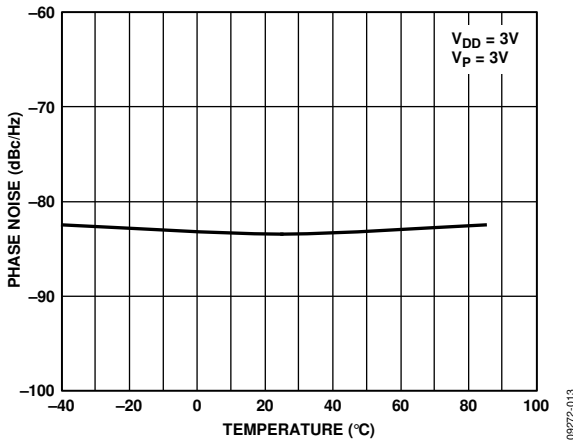

Figure 13. Phase Noise (5.8 GHz, 1 MHz, and 100 kHz) vs. Temperature

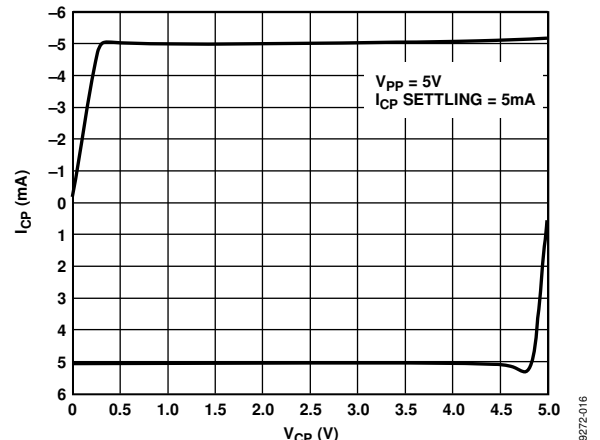

Figure 16. Charge Pump Output Characteristics

PRINTED CIRCUIT BOARD (PCB) DESIGN GUIDELINES FOR CHIP SCALE PACKAGE

The lands on the 20-lead LFCSP (CP-20-6) are rectangular. The PCB pad for these should be 0.1 mm longer than the package land length and 0.05 mm wider than the package land width. The land should be centered on the pad. This ensures that the solder joint size is maximized. The bottom of the LFCSP has a central thermal pad.

The thermal pad on the PCB should be at least as large as this exposed pad. On the PCB, there should be a clearance of at least 0.25 mm between the thermal pad and the inner edges of the pad pattern. This ensures that shorting is avoided.

Thermal vias may be used on the PCB thermal pad to improve thermal performance of the package. If vias are used, they should be incorporated in the thermal pad at 1.2 mm pitch grid. The via diameter should be between 0.3 mm and 0.33 mm, and the via barrel should be plated with 1 oz. copper to plug the via.

The user should connect the PCB thermal pad to AGND.

OUTLINE DIMENSIONS

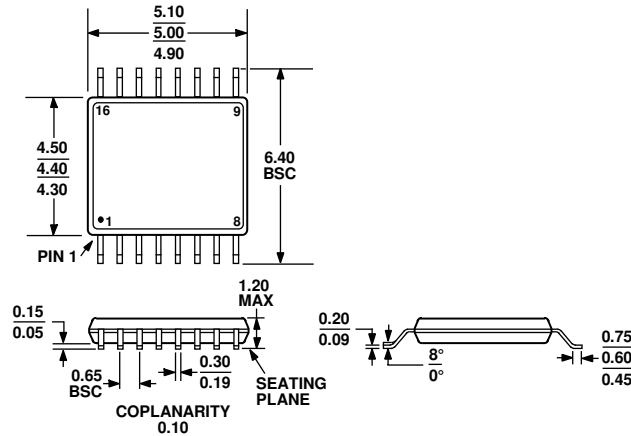

COMPLIANT TO JEDEC STANDARDS MO-153-AB

Figure 17. 16-Lead Thin Shrink Small Outline Package [TSSOP] (RU-16)

Dimensions shown in millimeters

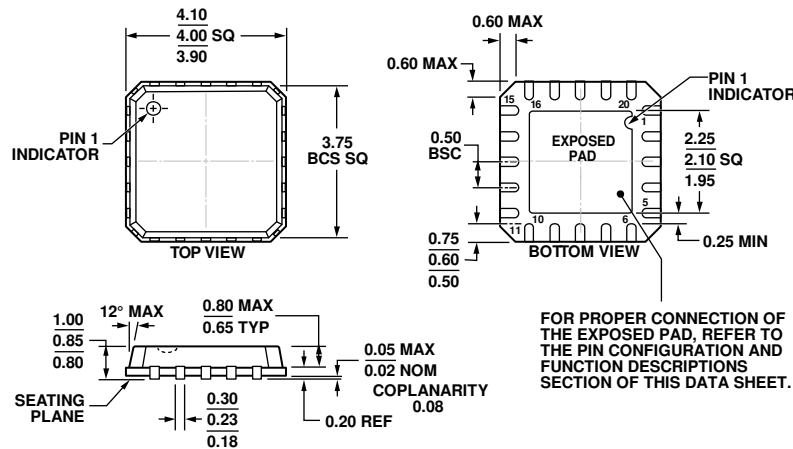

COMPLIANT TO JEDEC STANDARDS MO-220-VGGD-1

Figure 18. 20-Lead Lead Frame Chip Scale Package [LFCSP_VQ] 4 mm × 4 mm Body, Very Thin Quad (CP-20-6)

Dimensions shown in millimeters

ORDERING GUIDE

Model ¹	Temperature Range	Package Description	Package Option
ADF4106SRU-EP	-55°C to +125°C	16-Lead Thin Shrink Small Outline Package [TSSOP]	RU-16
ADF4106SRU-EP-R7	-55°C to +125°C	16-Lead Thin Shrink Small Outline Package [TSSOP]	RU-16
ADF4106SRUZ-EP	-55°C to +125°C	16-Lead Thin Shrink Small Outline Package [TSSOP]	RU-16
ADF4106SRUZ-EP-R7	-55°C to +125°C	16-Lead Thin Shrink Small Outline Package [TSSOP]	RU-16
ADF4106SCPZ-EP	-55°C to +125°C	20-Lead Lead Frame Chip Scale Package [LFCSP_VQ]	CP-20-6
ADF4106SCPZ-EP-R7	-55°C to +125°C	20-Lead Lead Frame Chip Scale Package [LFCSP_VQ]	CP-20-6

¹ Z = RoHS Compliant Part.