

## TAS2110EVM User's Guide

The TAS2110EVM is designed to demonstrate the performance of TAS2110 in a mono configuration. The design utilizes a USB interface to allow a PC to control the EVM. TAS2110 is a mono, digital-input, Class-D audio amplifier optimized for efficiently driving high peak power into small loudspeaker applications. The Class-D amplifier is capable of delivering 6 W of peak power into a 4  $\Omega$  load at a battery voltage of 4.2 V. Integrated speaker voltage and current sense provides real time monitoring of loud speakers

### Contents

1	Export Control Notice .....	2
2	Description .....	2
3	Specifications .....	2
4	Software .....	2
5	Device Configuration .....	3
6	Digital Audio Interfaces .....	8
7	EVM Schematics .....	10
8	EVM Layer Plots .....	13
9	Bill of Materials .....	16

### List of Figures

1	Requesting PPC3 Access .....	2
2	Default Jumper Settings .....	4
3	Speaker Connection.....	5
4	EVM Power .....	6
5	Windows Playback Devices .....	7
6	Texas Instruments USB Audio Device Control Panel.....	7
7	Windows Playback device Sample Rate .....	8
8	ASI Interface Pins .....	9
9	USB Interface.....	10
10	TAS2110.....	11
11	EVM Power .....	12
12	TAS2110EVM Top Silk Screen .....	13
13	TAS2110EVM Top Solder Mask .....	13
14	TAS2110EVM Top Copper .....	13
15	TAS2110EVM Copper Layer 2 .....	13
16	TAS2110EVM Copper Layer 3 .....	14
17	TAS2110EVM Bottom Copper .....	14
18	TAS2110EVM Bottom Solder .....	14
19	TAS2110EVM Bottom Silk Screen .....	14

### List of Tables

1	Specifications.....	2
2	Default Jumper Settings .....	3
3	Bill of Materials .....	16

## Trademarks

PurePath is a trademark of Texas Instruments.  
 Microsoft, Windows are registered trademarks of Microsoft Corporation.

## 1 Export Control Notice

Recipient agrees to not knowingly export or re-export, directly or indirectly, any product or technical data (as defined by the U.S., EU, and other Export Administration Regulations) including software, or any controlled product restricted by other applicable national regulations, received from disclosing party under nondisclosure obligations (if any), or any direct product of such technology, to any destination to which such export or re-export is restricted or prohibited by U.S. or other applicable laws, without obtaining prior authorization from U.S. Department of Commerce and other competent Government authorities to the extent required by those laws.

## 2 Description

TAS2110EVM supports evaluation and development with the TAS2110 device through the following interfaces:

- USB Interface
- Software control via PurePath™ Console 3 (PPC 3) GUI, USB-HID
- USB-class audio device, compatible with Microsoft® Windows® 7+
- External 100 – mil headers
- PSIA - I2S/TDM interface
- I<sup>2</sup>C
- Hardware Shutdown Control
- Interrupt Output

## 3 Specifications

Table 1 lists the supply, input, and output requirements for TAS2110.

**Table 1. Specifications**

Parameter	Value
Supply Voltage - VBAT	2.7 to 5.5 V
Supply Voltage - VDD	1.65 to 1.95 V
Input Logic	VDD
Output Power	6 W
USB, USB class-audio	Micro-USB

## 4 Software

The TAS2110 can be easily configured with PPC3 running the TAS2110 plug-in. To request access to the software first request a myTI.com account [here](#).

After creating an account, navigate to the [TAS2110 product page](#) and follow the link in the information box to request access to the software.

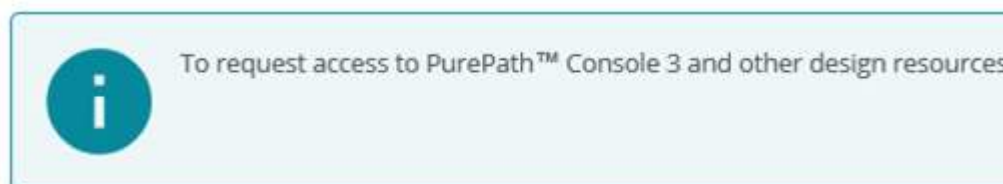

**Figure 1. Requesting PPC3 Access**

## 5 Device Configuration

The default configuration for the TAS2110 is described below in [Table 2](#) and [Figure 2](#).

### 5.1 Default Jumper Settings

The jumper settings below will configure the EVM for I2C and I2S inputs over USB.

**Table 2. Default Jumper Settings**

Jumper	Setting	Description
J3	Insert (1-2)	FSYNC
J4	Insert (1-2)	SBCLK
J5	Insert (1-2)	SDIN
J6	Insert (1-2)	GPIO
J7 (1&2)	Insert	VBAT
J7 (3&4)	Insert	VBAT
J8	Remove	I2C Source Level (3.3 V = Out , 1.8 V In) <b>DO NOT INSERT UNLESS PROVIDING I2C EXTERNALLY AT 1.8 V</b>
J9	Insert (1-2)	SCL
J11	Insert (1-2)	SDA
J12	Remove	SDOUT (3.3V)
J13	Insert	VDD
J14	Remove	SDOUT(1.8V)
J15	Remove	Output Sense

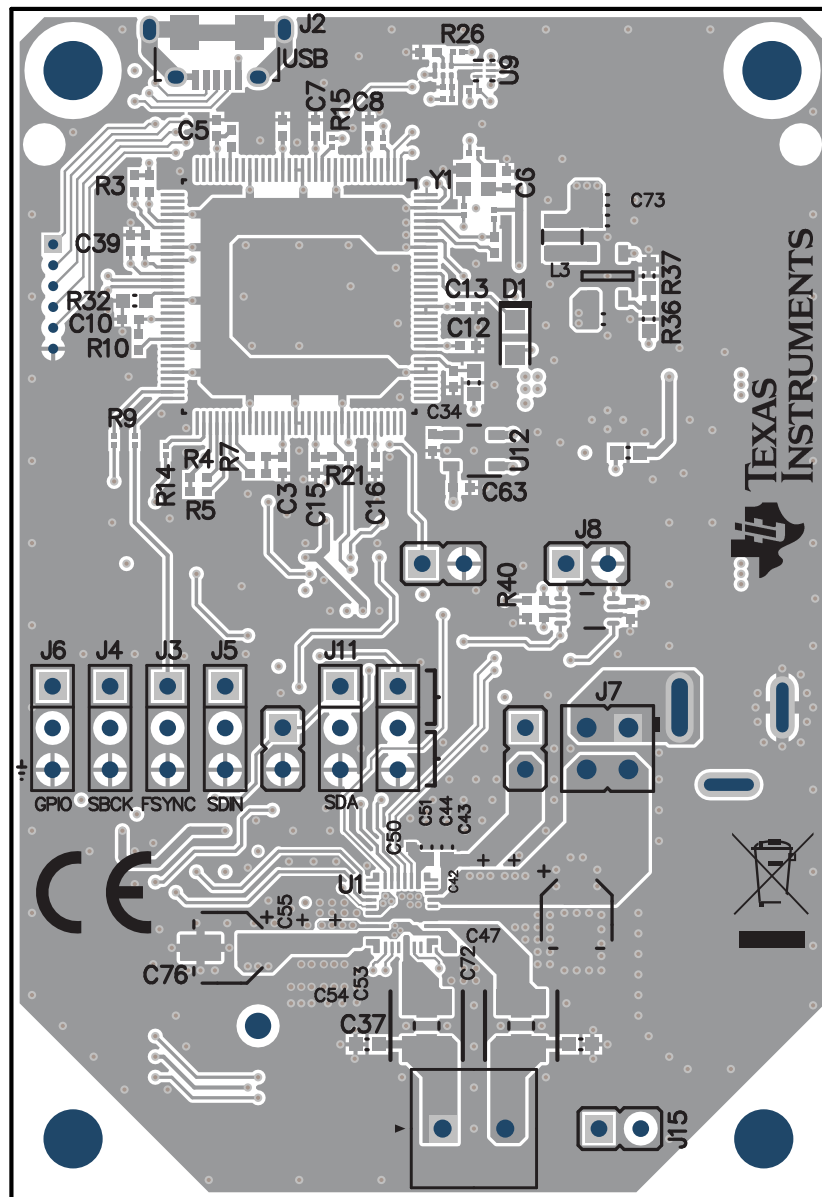

**Figure 2. Default Jumper Settings**

## 5.2 Address Selection

TAS2110EVM is configured to respond to I<sup>2</sup>C address 0x98 (8-bit). However, in the end application it may be configured to one of four addresses shown in section 8.3.2 of the TAS2110 Datasheet. If desired, the address may be changed on the EVM by configuring R18, R19, R20, and R35 as needed.

## 5.3 EVM Setup

Use the following instructions to complete a typical USB driven setup:

1. Install PPC3 with the TAS2110 plug-in
2. Connect a speaker to J10 on the TAS2110EVM

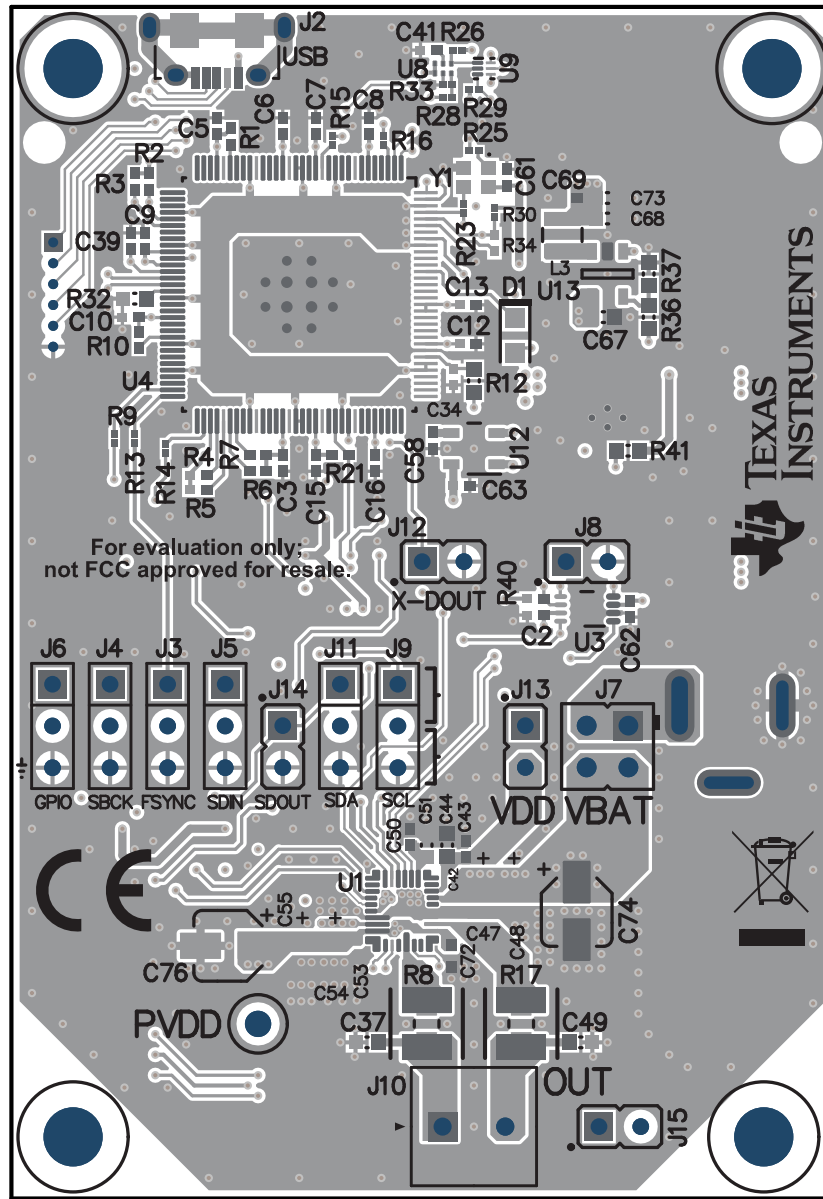

**Figure 3. Speaker Connection**

3. Check that Jumpers match the default jumper configuration shown in [Table 2](#)
4. Connect a 5-V supply to connector J16 as shown in [Figure 4](#)

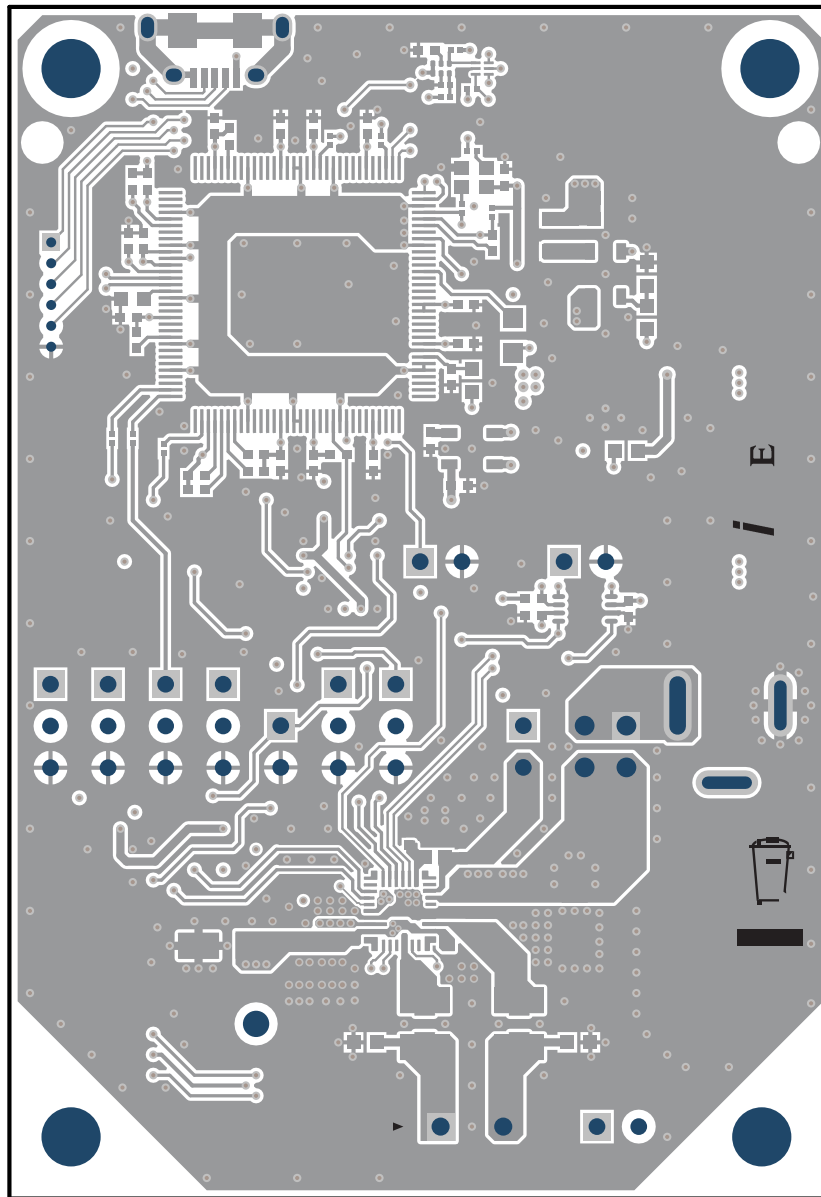

**Figure 4. EVM Power**

5. Connect a Micro USB Cable from PC to J2
6. Verify that TI USB Audio UAC2.0 is the default playback device by opening the sound dialog from the Windows Control Panel

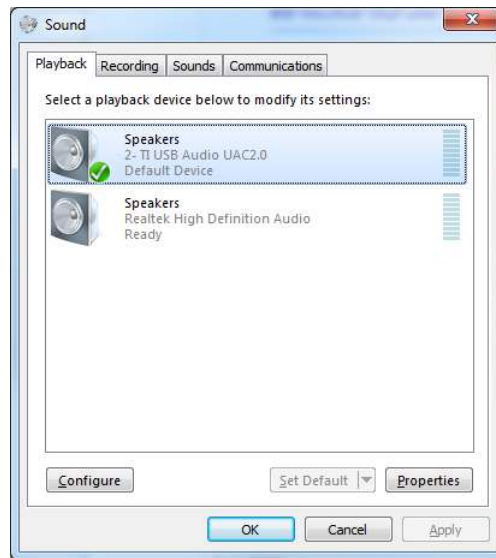

**Figure 5. Windows Playback Devices**

7. Set the maximum bit depth using the Texas Instruments USB Audio Device Control Panel found in the system tray

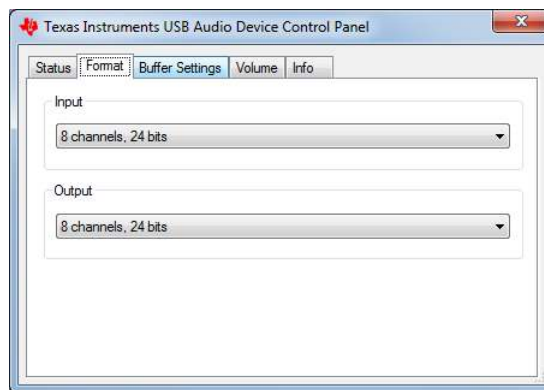

**Figure 6. Texas Instruments USB Audio Device Control Panel**

8. Set the sampling rate
  - Right click TI USB Audio UAC2.0
  - Select Properties
  - Click advanced tab
  - Select Rate

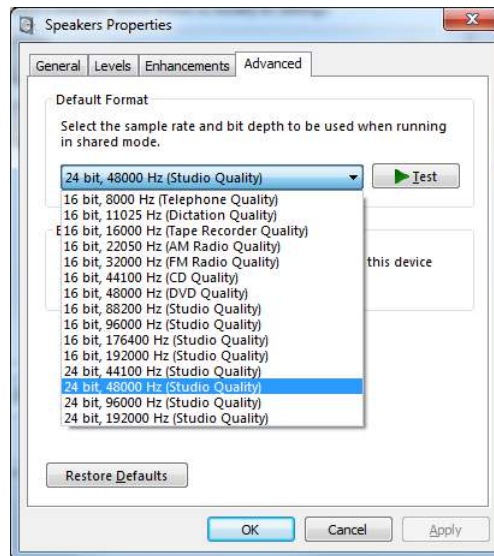

**Figure 7. Windows Playback device Sample Rate**

9. Configure the device using the TAS2110 PPC3 Plug-in

## 6 Digital Audio Interfaces

Select the various digital audio interfaces on the TAS2110EVM through hardware settings and software settings. Several headers on TAS2110 allow access to the following digital audio signals:

- I2S Data out (SDOUT) from the TAS2110 (for example, current and voltage sense data)
- I2S Data in (SDIN) to the TAS2110
- I2S Word clock or frame sync (FSYNC)
- I2S Bit clock (SBCLK)
- I<sup>2</sup>C Clock (SCLK)
- I<sup>2</sup>C Data (SDA)

To provide I2S data from an external source:

- Remove jumpers J4, J3, and J5
- Connect to SBCK, FSYNC, and SDIN by using pins 2-3 of Jumpers J4, J3, and J5
  - Signal is Pin 2
  - GND is Pin 3
- SDOUT is available at a 1.8-V logic level through J14 or 3.3-V logic level through J12
- I2S signals may operate at either 1.8-V or 3.3-V logic



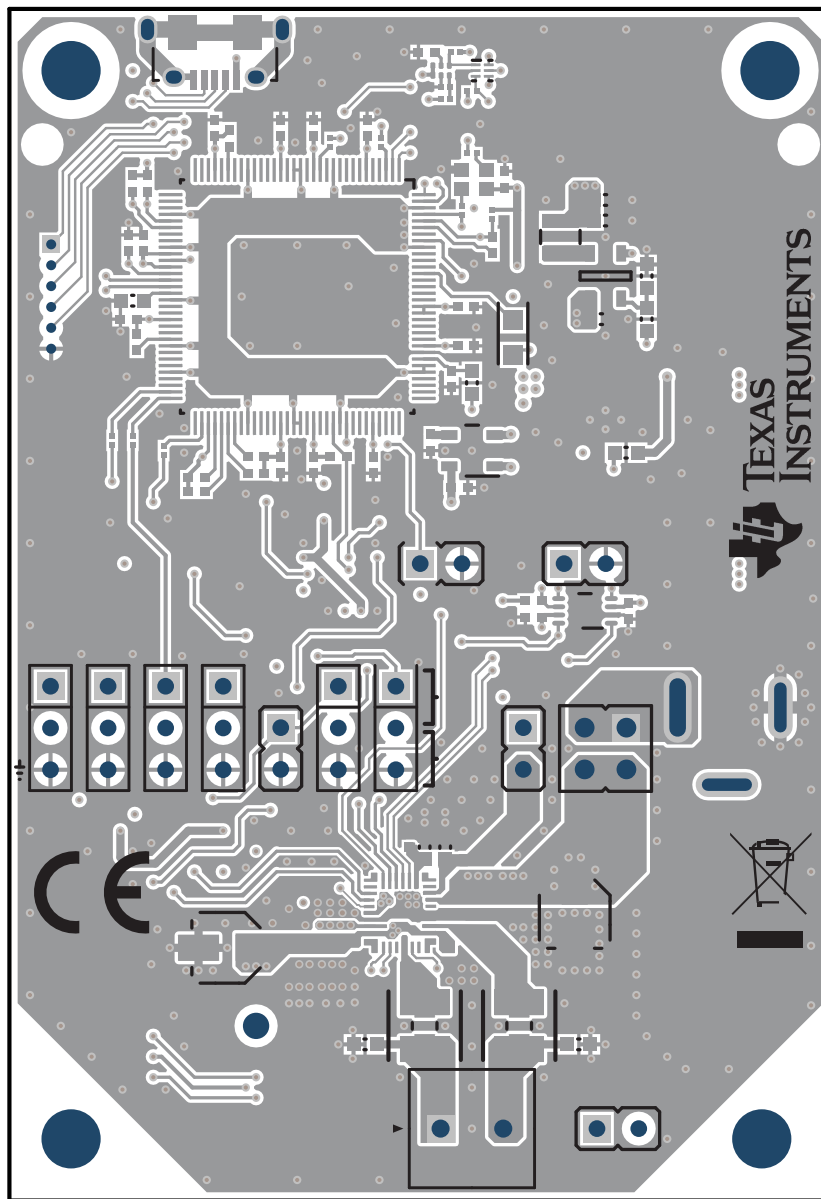

**Figure 8. ASI Interface Pins**

To Provide I<sup>2</sup>C from an external source:

- Remove Jumpers J11 and J9
- Configure I<sup>2</sup>C for input logic level
  - Remove J8 for 3.3 V
  - Insert J8 for 1.8 V
- Connect to SDA and SCL through Jumpers J11 and J9
  - Pin 2 is Signal
  - Pin 3 is GND

## 7 EVM Schematics

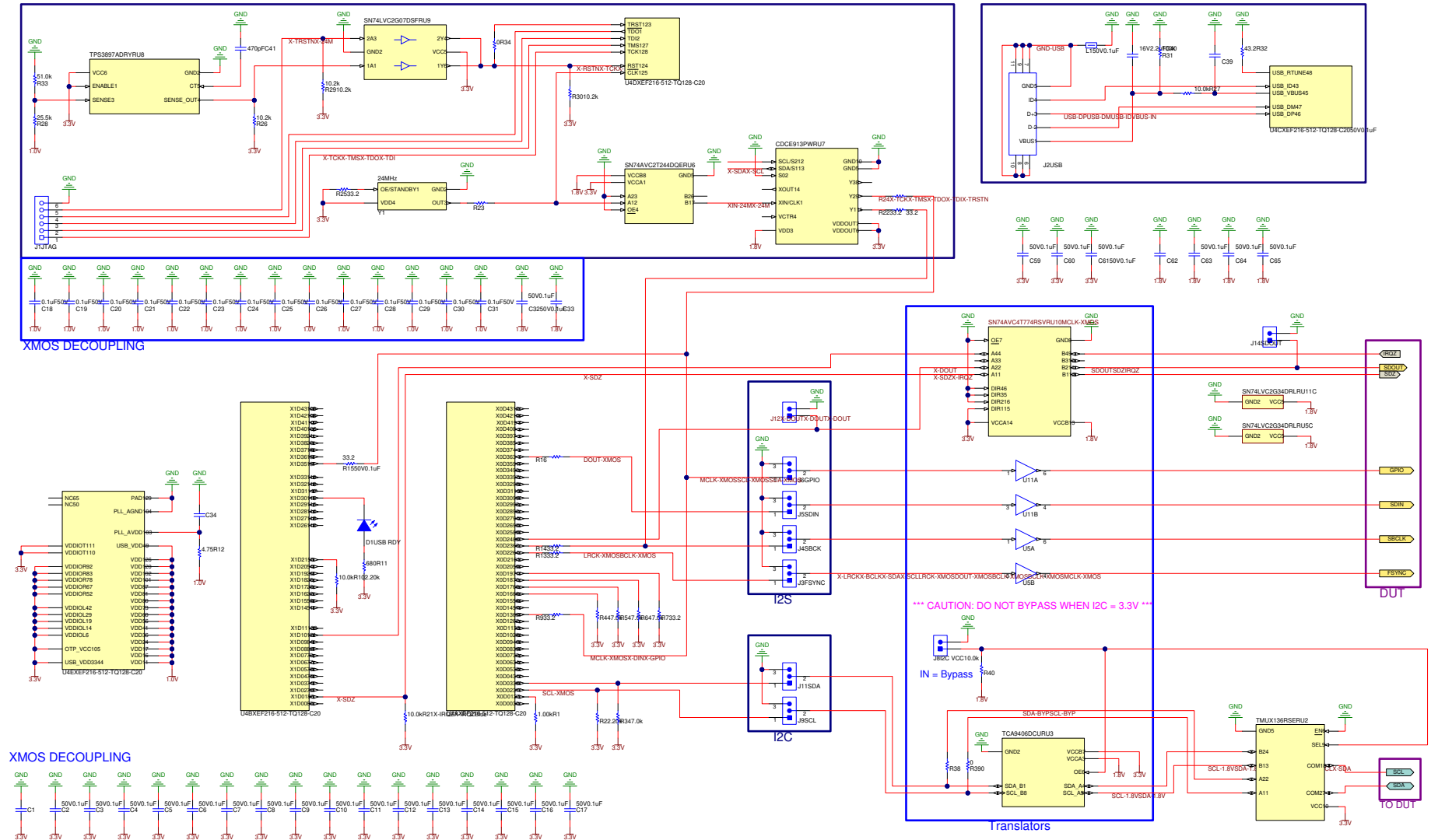

Figure 9. USB Interface

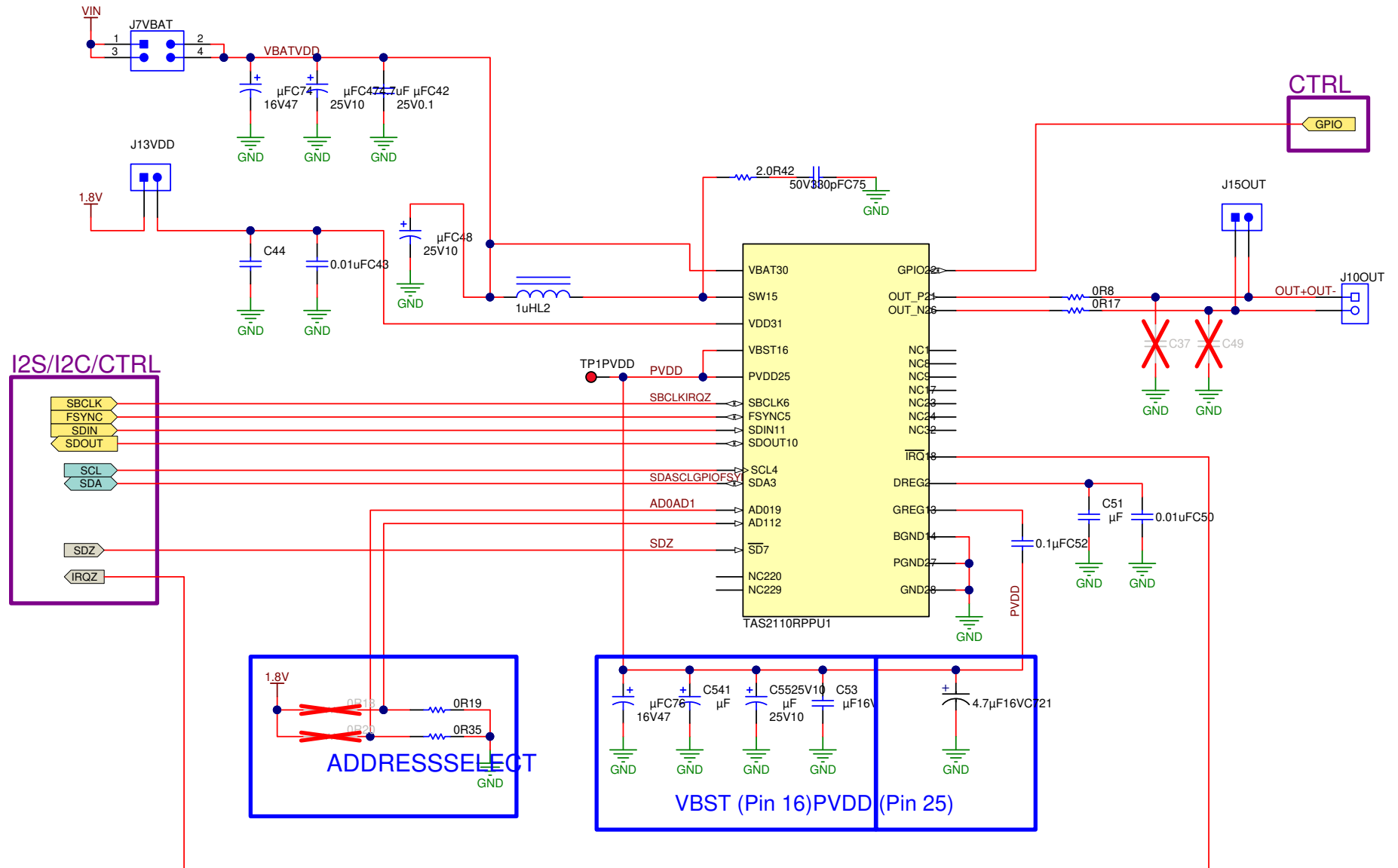
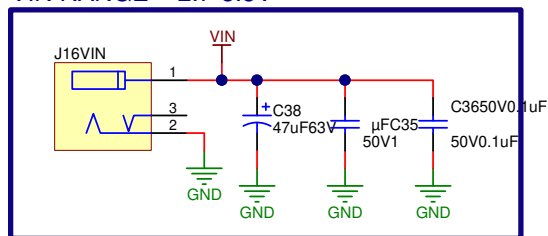
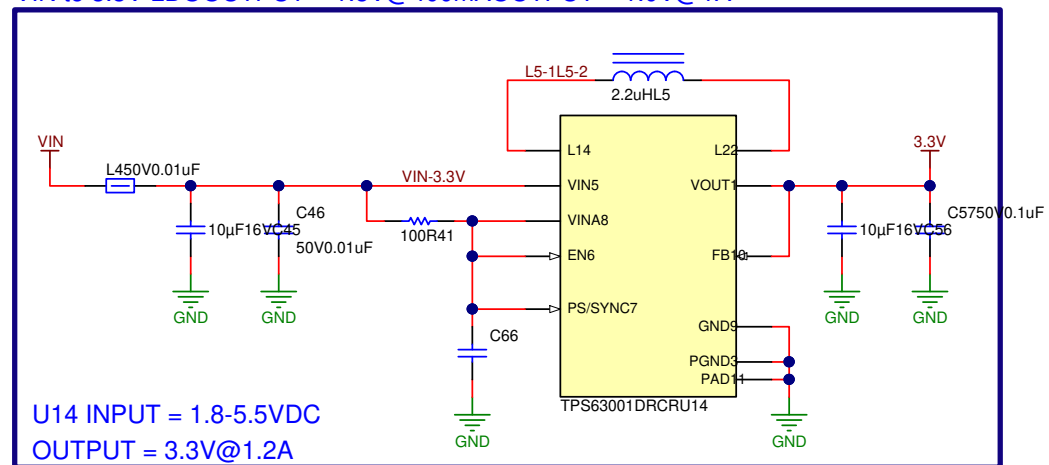

Figure 10. TAS2110

VIN RANGE = 2.7-5.5V



VIN to 3.3V LDO OUTPUT = 1.8V@400mA OUTPUT = 1.0V@1A



3.3V to 1.8V LDO

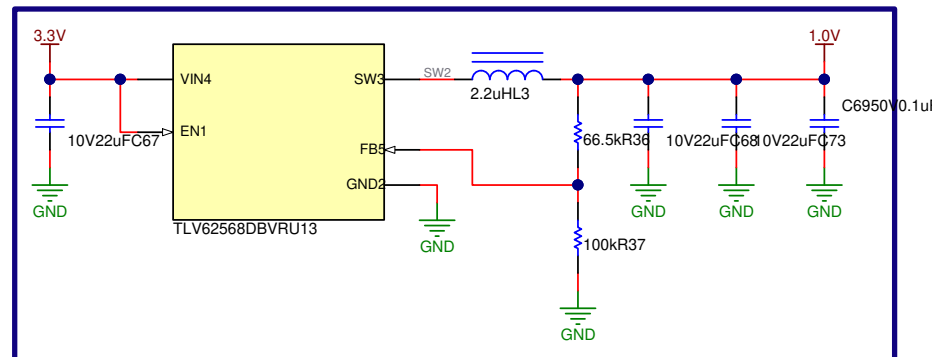
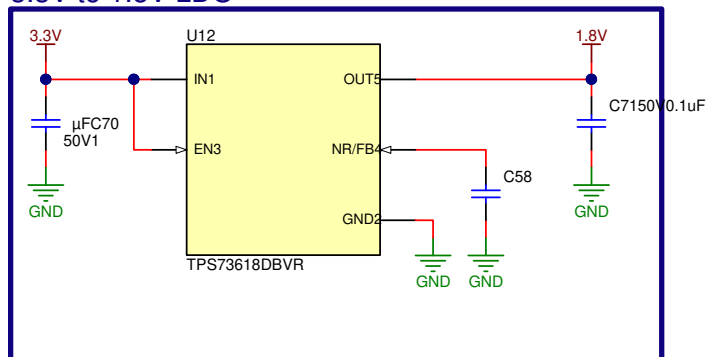

Figure 11. EVM Power

## 8 EVM Layer Plots

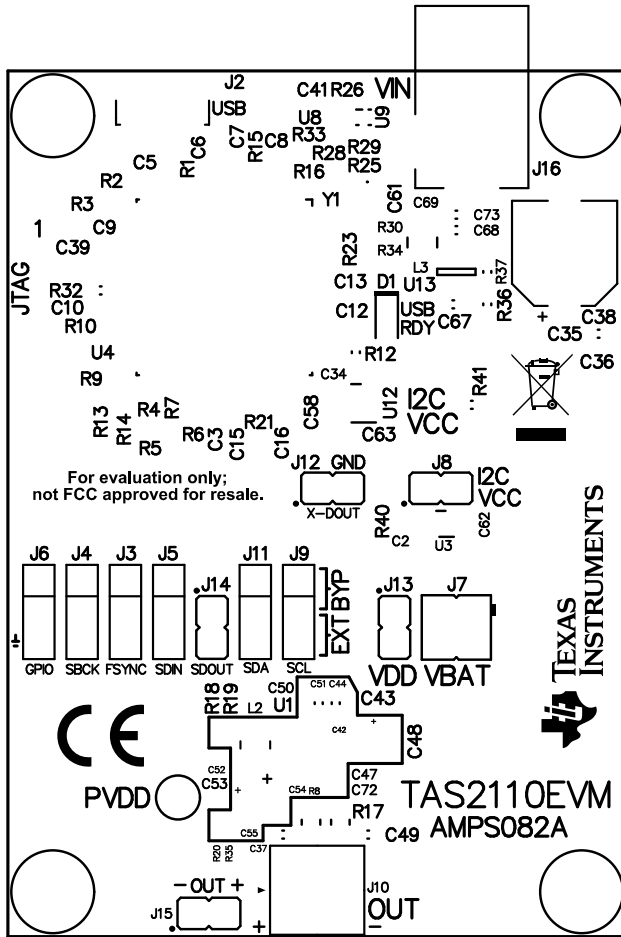

Figure 12. TAS2110EVM Top Silk Screen

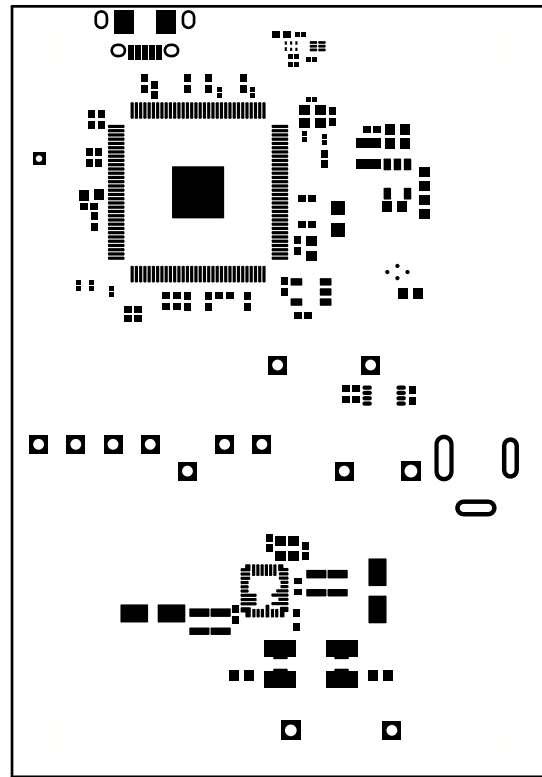

Figure 13. TAS2110EVM Top Solder Mask

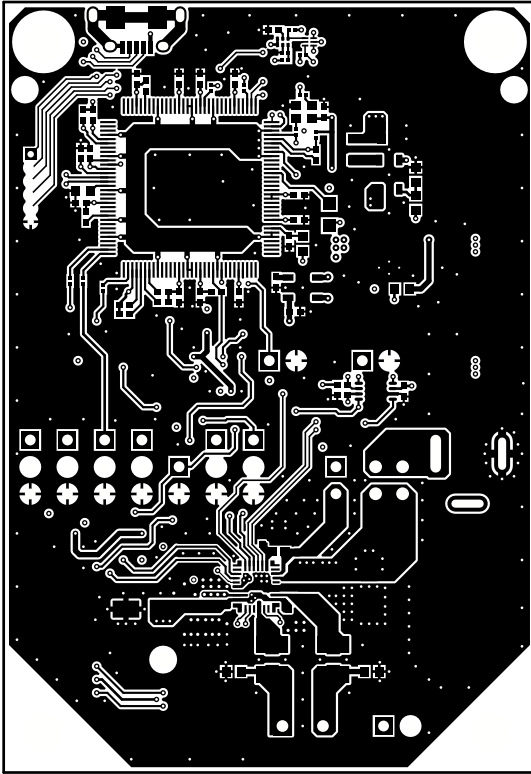

Figure 14. TAS2110EVM Top Copper

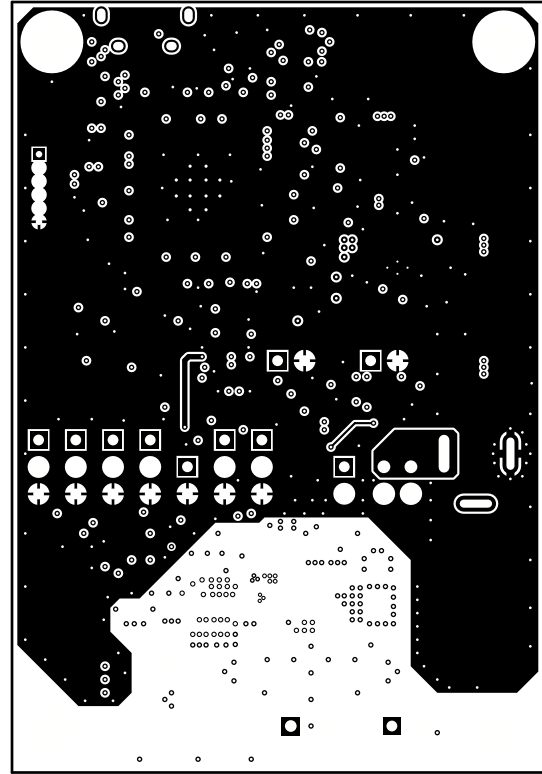

Figure 15. TAS2110EVM Copper Layer 2

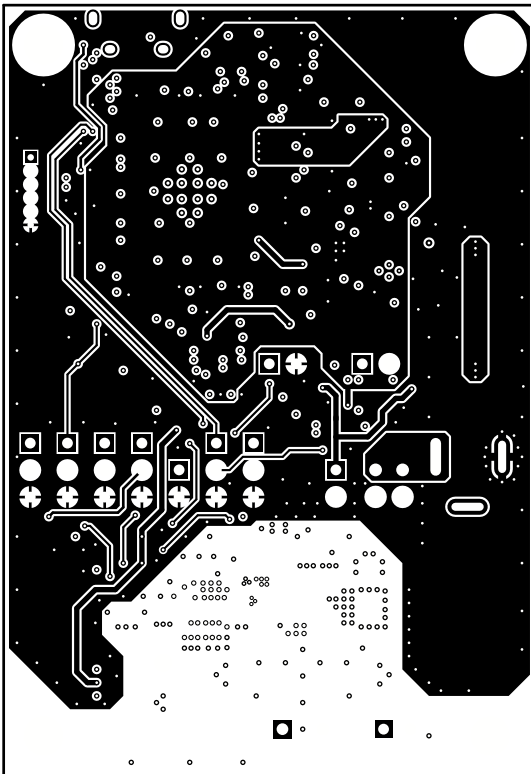

Figure 16. TAS2110EVM Copper Layer 3

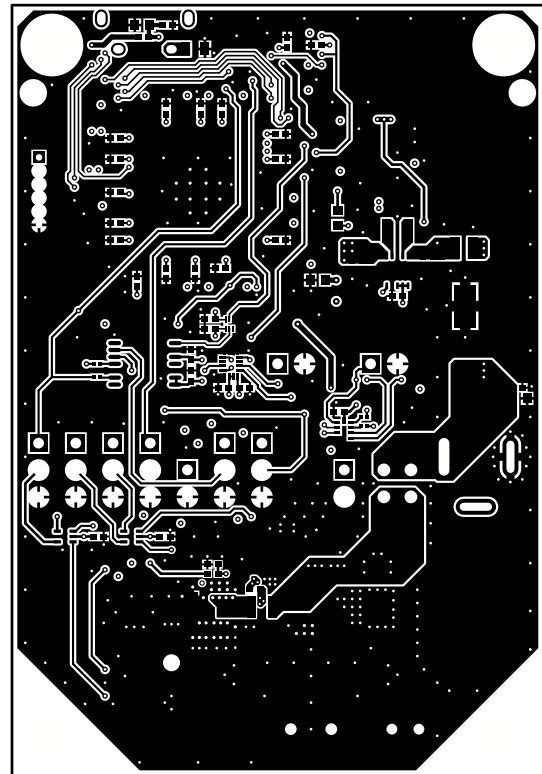

Figure 17. TAS2110EVM Bottom Copper

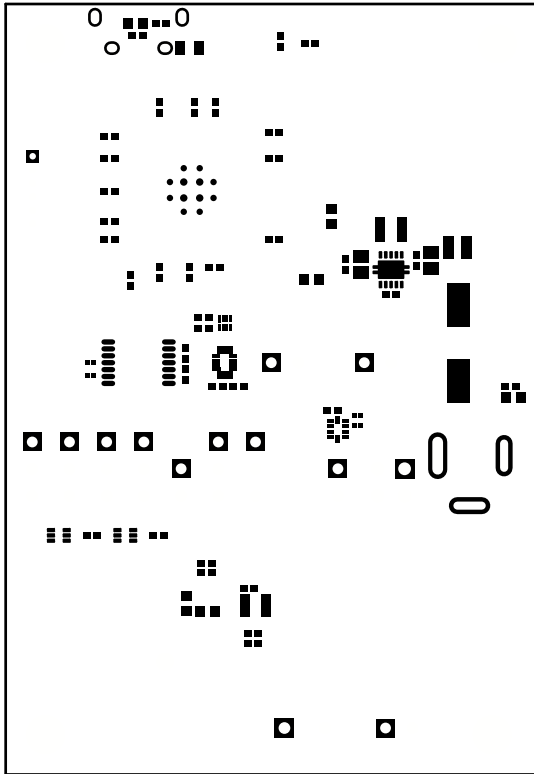

Figure 18. TAS2110EVM Bottom Solder

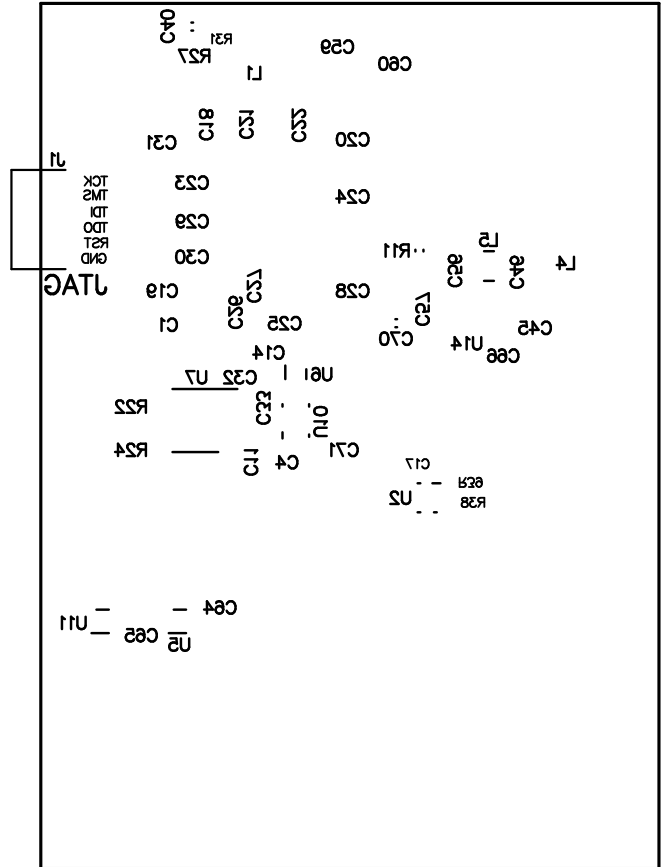

Figure 19. TAS2110EVM Bottom Silk Screen

**9 Bill of Materials**
**Table 3. Bill of Materials**

Designator	Value	Description	PackageReference	PartNumber	Manufacturer	Alternate PartNumber	Alternate Manufacturer
!PCB1		Printed Circuit Board		AMPS043	Any		
C1, C2, C6, C10, C13, C14, C18, C22	10uF	CAP, CERM, 10 uF, 35 V, +/- 10%, X7R, AEC-Q200 Grade 1, 1206_190	1206_190	CGA5L1X7R1V106K160AC	TDK		
C4, C16	4.7uF	CAP, CERM, 4.7 uF, 10 V, +/- 10%, X5R, 0603	0603	CGB3B1X5R1A475K055AC	TDK		
C9, C21	1uF	CAP, CERM, 1 uF, 16 V, +/- 20%, X7R, 0603	0603	CL10B105MO8NNWC	Samsung		
C12, C24, C29, C30	0.1uF	CAP, CERM, 0.1 uF, 25 V, +/- 10%, X7R, AEC-Q200 Grade 1, 0402	0402	CGA2B3X7R1E104K050BB	TDK		
J1, J2		Receptacle, 2.54 mm, 20 x 2, Gold, TH	Receptacle, 2.54 1mm, 20 x 2, TH	SSQ-120-23-G-D	Samtec		
J3, J4, J6, J7, J14, J15, J16		Header, 100 mil, 2 x 1, Gold, TH	Sullins 100 mil, 1 x 2, 230 mil above insulator	PBC02SAAN	Sullins Connector Solutions		
J5, J8		Conn Term Block, 2POS, 3.81 mm, TH	2POS Terminal Block	1727010	Phoenix Contact		
J9		Header, 2.54 mm, 2 x 2, Gold, TH	Header, 2.5 4 mm, 2 x 2 TH	PBC02DAAN	Sullins Connector Solutions		
J10, J11, J12, J13		Header, 10 0mil, 3 x 1, Gold, TH	PBC03SAAN	PBC03SAAN	Sullins Connector Solutions		
L1, L2	1uH	Inductor, Shielded, Metal Composite, 1 uH, 3.3 A, 0.04 ohm, SMD	2.5 x 1.2 x 2 mm	DFE252012F-1R0M=P2	MuRata Toko		
R1, R2, R8, R9	0	RES, 0, 5%, 0.125 W, 0805	0805	RC0805JR-070RL	Yageo America		
R3, R6	10.0k	RES, 10.0 k, 1%, 0.063 W, AEC-Q200 Grade 0, 0402	0402	RMCF0402FT10K0	Stackpole Electronics Inc		
R4, R5, R11, R12	0	RES, 0, 5%, 0.063 W, 0402	0402	ERJ-2GE0R00X	Panasonic		
R7	0	RES, 0, 5%, 0.1 W, 0603	0603	ERJ-3GEY0R00V	Panasonic		



Table 3. Bill of Materials (continued)

Designator	Value	Description	PackageReference	PartNumber	Manufacturer	Alternate PartNumber	Alternate Manufacturer
SH-J1, SH-J2, SH-J3, SH-J4, SH-J5, SH-J6, SH-J7, SH-J8, SH-J9, SH-J10, SH-J11	1x2	Shunt, 100 mil, Gold plated, Black	Shunt	SNT-100-BK-G	Samtec	969102-0000-DA	3M
TP1, TP11		Test Point, Compact, Red, TH	Red Compact Testpoint	5005	Keystone		
TP2, TP12, TP13, TP14		Test Point, Miniature, Black, TH	Black Miniature Testpoint	5001	Keystone		
TP3, TP4, TP5, TP6, TP7, TP8, TP9, TP10		Test Point, Miniature, Orange, TH	Orange Miniature Testpoint	5003	Keystone		
U1, U2		6W Boosted Class-D Audio Amplifier with IV-sense, YBG0036-C02 (DSBGA-36)	YBG0036-C02	TAS2564YBGR	Texas Instruments	TAS2564YBGT	Texas Instruments
U3		EEPROM, 512 KBIT, 400 KHZ, 8TSSOP	TSSOP-8	24FC512-I/ST	Microchip		
U4		Single Bus Buffer Gate With 3-State Outputs, DCK0005A, LARGE T&R	DCK0005A	SN74LVC1G125DCKR	Texas Instruments		
C3, C15	0.1uF	CAP, CERM, 0.1 $\mu$ F, 25 V, +/- 10%, X7R, AEC-Q200 Grade 1, 0402	0402	CGA2B3X7R1E104K050BB	TDK		
C5, C7, C8, C11, C17, C19, C20, C23	0.01uF	CAP, CERM, 0.01 $\mu$ F, 25 V, +/- 10%, X7R, 0402	0402	GCM155R71E103KA37D	MuRata		
C25, C26, C27, C28	1uF	CAP, CERM, 1 $\mu$ F, 16 V, +/- 20%, X7R, 0603	0603	CL10B105MO8NNWC	Samsung		
FID1, FID2, FID3, FID4, FID5, FID6		Fiducial mark. There is nothing to buy or mount.	N/A	N/A	N/A		
L3, L4	1uH	Inductor, 1 $\mu$ H, 7 A, 0.014 ohm, SMD	4.15 x 4 mm	PCMB053T-1R0MS	Susumu Co Ltd		
R10, R13	0	RES, 0, 5%, 1 W, 2512	2512	RC6432J000CS	Samsung		



---

**IMPORTANT NOTICE AND DISCLAIMER**

TI PROVIDES TECHNICAL AND RELIABILITY DATA (INCLUDING DATASHEETS), DESIGN RESOURCES (INCLUDING REFERENCE DESIGNS), APPLICATION OR OTHER DESIGN ADVICE, WEB TOOLS, SAFETY INFORMATION, AND OTHER RESOURCES “AS IS” AND WITH ALL FAULTS, AND DISCLAIMS ALL WARRANTIES, EXPRESS AND IMPLIED, INCLUDING WITHOUT LIMITATION ANY IMPLIED WARRANTIES OF MERCHANTABILITY, FITNESS FOR A PARTICULAR PURPOSE OR NON-INFRINGEMENT OF THIRD PARTY INTELLECTUAL PROPERTY RIGHTS.

These resources are intended for skilled developers designing with TI products. You are solely responsible for (1) selecting the appropriate TI products for your application, (2) designing, validating and testing your application, and (3) ensuring your application meets applicable standards, and any other safety, security, or other requirements. These resources are subject to change without notice. TI grants you permission to use these resources only for development of an application that uses the TI products described in the resource. Other reproduction and display of these resources is prohibited. No license is granted to any other TI intellectual property right or to any third party intellectual property right. TI disclaims responsibility for, and you will fully indemnify TI and its representatives against, any claims, damages, costs, losses, and liabilities arising out of your use of these resources.

TI's products are provided subject to TI's Terms of Sale ([www.ti.com/legal/termsofsale.html](http://www.ti.com/legal/termsofsale.html)) or other applicable terms available either on [ti.com](http://ti.com) or provided in conjunction with such TI products. TI's provision of these resources does not expand or otherwise alter TI's applicable warranties or warranty disclaimers for TI products.

Mailing Address: Texas Instruments, Post Office Box 655303, Dallas, Texas 75265  
Copyright © 2019, Texas Instruments Incorporated

## IMPORTANT NOTICE AND DISCLAIMER

TI PROVIDES TECHNICAL AND RELIABILITY DATA (INCLUDING DATASHEETS), DESIGN RESOURCES (INCLUDING REFERENCE DESIGNS), APPLICATION OR OTHER DESIGN ADVICE, WEB TOOLS, SAFETY INFORMATION, AND OTHER RESOURCES "AS IS" AND WITH ALL FAULTS, AND DISCLAIMS ALL WARRANTIES, EXPRESS AND IMPLIED, INCLUDING WITHOUT LIMITATION ANY IMPLIED WARRANTIES OF MERCHANTABILITY, FITNESS FOR A PARTICULAR PURPOSE OR NON-INFRINGEMENT OF THIRD PARTY INTELLECTUAL PROPERTY RIGHTS.

These resources are intended for skilled developers designing with TI products. You are solely responsible for (1) selecting the appropriate TI products for your application, (2) designing, validating and testing your application, and (3) ensuring your application meets applicable standards, and any other safety, security, or other requirements. These resources are subject to change without notice. TI grants you permission to use these resources only for development of an application that uses the TI products described in the resource. Other reproduction and display of these resources is prohibited. No license is granted to any other TI intellectual property right or to any third party intellectual property right. TI disclaims responsibility for, and you will fully indemnify TI and its representatives against, any claims, damages, costs, losses, and liabilities arising out of your use of these resources.

TI's products are provided subject to TI's Terms of Sale ([www.ti.com/legal/termsofsale.html](http://www.ti.com/legal/termsofsale.html)) or other applicable terms available either on [ti.com](http://ti.com) or provided in conjunction with such TI products. TI's provision of these resources does not expand or otherwise alter TI's applicable warranties or warranty disclaimers for TI products.

Mailing Address: Texas Instruments, Post Office Box 655303, Dallas, Texas 75265  
Copyright © 2019, Texas Instruments Incorporated