



PRODUCT SPECIFICATION



LANGUAGE
JAPANESE
ENGLISH

【1. 適用範囲 SCOPE】

本仕様書は、_____ 殿 に納入する
_____ 3.7 MULTIPLE CONNECTOR _____ について規定する。
This specification covers the 3.7 MULTIPLE CONNECTOR series.

【2. 製品名称及び型番 PRODUCT NAME AND PART NUMBER】

製品名称 Product Name	製品型番 Part Number
リセプタクルハウジングアッセンブリ Receptacle Housing Assembly	503471-0209
プラグハウジングアッセンブリ Plug Housing Assembly	503469-0209
503471-0209テーピング梱包品 Embossed Tape Package for 503471-0209	503471-0200
503469-0209テーピング梱包品 Embossed Tape Package for 503469-0209	503469-0200
リセプタクル短絡ハウジングアッセンブリ Receptacle Short Housing Assembly	503474-0200
プラグ圧着ハウジング Plug Crimp Housing	503473-0200
プラグ圧着ターミナル Plug Crimp Terminal	503485-0000

※ 製品形状及び寸法については弊社製品図面を参照願います。
※ Please refer to MX drawing for detailed dimensions and shape.

REV.	A																			
SHEET	1-15																			
REVISE ON PC ONLY										TITLE: 3.7 MULTIPLE CONNECTOR SERIES										
A		新規作成 RELEASED ECN No. J2010-0155 2009/7/24 H.KOBAYASHI								製品仕様書										
THIS DOCUMENT CONTAINS INFORMATION THAT IS PROPRIETARY TO MOLEX INC. AND SHOULD NOT BE USED WITHOUT WRITTEN PERMISSION																				
REV.	DESCRIPTION																			
DESIGN CONTROL J					STATUS					WRITTEN BY: H.KOBAYASHI	CHECKED BY: S.SATO	APPROVED BY: N.UKITA	DATE : YR/MO/DAY 2009/ 7/24							

DOCUMENT NUMBER PS-503471-001	FILE NAME PS503471001.doc	SHEET 1 OF 15
---	------------------------------	------------------



PRODUCT SPECIFICATION



LANGUAGE

JAPANESE
ENGLISH

【3. 定格 RATINGS】

項目 Item	規格 Standard	
最大許容電圧 Rated Voltage (MAX.)	500 V	
最大許容電流 及び 適用電線 Rated Current (MAX.) and Applicable wires	AWG#26	2 A
	AWG#28	2 A
使用温度範囲 ^{*2} Ambient Temperature Range	-40°C~+ 85°C ^{*1} 低温において氷結しないこと Not freeze to low temperature	
製品保存温湿度範囲 Storage Temperature Range of Connector	温度 : -40°C~+80°C、相対湿度 : 85%以下 Temperature : -40°C~+80°C、Percentage Humidity : 85% MAX.	
梱包保管 Storage of Package	温湿度条件 Temperature and Humidity Condition	温度 Temperature : -10°C~+40°C 相対湿度 Percentage Humidity : 70% MAX.
	期間 Term	1年 1 Year

*1 : 通電による温度上昇分も含む。

This includes the terminal temperature rise generated by conducting electricity.

*2 : 適合電線 (ケーブル等) も本使用温度範囲を満足すること。

Applicable wire (cables) must also meet the specified temperature range.

【4. 性能 PERFORMANCE】

4-1. 電気的性能 Electrical performance

項目 Item	条件 Test Condition	規格 Requirement
4-1-1 接触抵抗 Contact Resistance	コネクタを嵌合させ、開放電圧 20mV以下、 短絡電流 10mA にて測定する。 (JIS C5402 5.4) Mate connectors and measured by dry circuit, 20mV MAX., 10mA. (JIS C5402 5.4)	40 milliohms MAX.
4-1-2 絶縁抵抗 Insulation Resistance	コネクタを嵌合させ、隣接するターミナル間に、 DC 500Vを1分間印加し測定する。 (JIS C5402 5.2/MIL-STD-202 試験法 302) Mate connectors and apply 500V DC for 1 minute between adjacent terminal or ground. (JIS C5402 5.2/MIL-STD-202 Method 302)	1000 Megohms MIN.

REVISE ON PC ONLY

A

SEE SHEET 1 OF 15

TITLE:

3.7 MULTIPLE CONNECTOR SERIES

製品仕様書THIS DOCUMENT CONTAINS INFORMATION THAT IS PROPRIETARY TO
MOLEX INC. AND SHOULD NOT BE USED WITHOUT WRITTEN PERMISSION

REV.

DESCRIPTION

DOCUMENT NUMBER

PS-503471-001

FILE NAME

PS503471001.doc

SHEET

2 OF 15

EN-37-1(019)



PRODUCT SPECIFICATION



LANGUAGE

JAPANESE
ENGLISH

項目 Item	条件 Test Condition	規格 Requirement
4-1-3 耐電圧 Dielectric Strength	コネクタを嵌合させ、隣接するターミナル間及びターミナル、アース間に、AC(rms) 1500V (実効値) を1分間 印加する。 (JIS C5402 5.1/MIL-STD-202 試験法 301) Mate connectors and apply 1500V AC(rms) for 1 minute between adjacent terminal or ground. (JIS C5402 5.1/MIL-STD-202 Method 301)	異常なきこと No Breakdown
4-1-4 圧着部接触抵抗 Contact Resistance on Crimped Portion	ターミナルに適合電線を圧着し、開放電圧20mV以下、短絡電流10mAにて測定する。 Crimp the applicable wire on to the terminal, measure by dry circuit , 20mV MAX, 10mA.	5 milliohm MAX.

4-2. 機械的性能 Mechanical Performance

項目 Item	条件 Test Condition	規格 Requirement
4-2-1 挿入力及び抜去力 Insertion and Withdrawal Force	毎分 25±3mmの速さで挿入、抜去を行う。 Insert and withdrawal connectors At the speed rate of 25±3mm/minute.	503471 /503469 及び 503471 /503473 挿入力 Insertion 14.7N{1.5kgf} MAX.
		抜去力 Withdrawal 0.4N{0.04kgf} MIN.
		503469 /503474 挿入力 Insertion 19.6N{2.0kgf} MAX.
		抜去力 Withdrawal 4.9N{0.5kgf} MIN.
4-2-2 ターミナル保持力 Terminal Retention Force	ハウジングに装着されたターミナルを毎分 25±3mm の速さで軸方向に引張る。 Apply axial pull out force at the speed rate of 25±3mm/minute on the rec. terminal assembled in the rec. housing.	1.96N {0.2 kgf} MIN.

REVISE ON PC ONLY		TITLE: 3.7 MULTIPLE CONNECTOR SERIES	
A	SEE SHEET 1 OF 15	製品仕様書	
	REV.	DESCRIPTION	THIS DOCUMENT CONTAINS INFORMATION THAT IS PROPRIETARY TO MOLEX INC. AND SHOULD NOT BE USED WITHOUT WRITTEN PERMISSION
DOCUMENT NUMBER PS-503471-001		FILE NAME PS503471001.doc	SHEET 3 OF 15



PRODUCT SPECIFICATION



LANGUAGE

JAPANESE
ENGLISH

項目 Item		条件 Test Condition		規格 Requirement
4-2-3	圧着部引張強度 Crimping Pull out Force	圧着されたターミナルを治具に固定し、電線を軸方向に毎分 25±3mm の速さで引張る。 (JIS C5402 6.8) Fix the crimped terminal, apply axial pull out force on the wire at the speed rate of 25±3mm/minute. (JIS C5402 6.8)	AWG#26	9.8 N { 1.0 kgf } MIN.
			AWG#28	9.8 N { 1.0 kgf } MIN.
4-2-4	ターミナル挿入力 (圧着端子) Terminal Insertion Force (Crimp terminal)	圧着されたターミナルをハウジングに挿入する。 Insert the crimped terminal into the housing.		4.9 N { 0.5 kgf } MAX.
4-2-5	ターミナル保持力 (圧着端子) Terminal Retention Force (Crimp terminal)	圧着されたターミナルをハウジングに装着し、電線を軸方向に毎分 25±3mm の速さで引張る。 Apply axial pull out force at the speed rate of 25±3mm/minute on the terminal assembled in the housing.		6.9N {0.7 kgf} MIN.
4-2-6	ハウジングロック力 Housing Retention Force	コネクタを嵌合させ、ロックを解除せずに毎分25±3mm の速さで軸方向に引張る。 (試験サンプルは、端子装着状態とする。) Mate connectors, apply axial pull out force at the speed rate of 25±3mm /minute when it not discharge lock. (Test sample have pin/terminal.)		9.8 N { 1.0 kgf } MIN.

REVISE ON PC ONLY		TITLE:	
A	SEE SHEET 1 OF 15	3.7 MULTIPLE CONNECTOR SERIES	
		製品仕様書	
REV.	DESCRIPTION	THIS DOCUMENT CONTAINS INFORMATION THAT IS PROPRIETARY TO MOLEX INC. AND SHOULD NOT BE USED WITHOUT WRITTEN PERMISSION	
DOCUMENT NUMBER PS-503471-001		FILE NAME PS503471001.doc	SHEET 4 OF 15



PRODUCT SPECIFICATION



LANGUAGE

JAPANESE
ENGLISH

4-3. その他 Environmental Performance and Others

項目 Item		条件 Test Condition		規格 Requirement	
4-3-1	挿抜寿命 Repeated Insertion / Withdrawal	1分間 10回 以下の速さで、挿入、抜去を繰り返す。 When mated repeatedly by the rate of 10 cycles per minute.	挿抜回数：15回 15 cycles 嵌合組み合わせ Mate connector	接触抵抗 Contact Resistance	80 milliohms MAX.
			503471 / 503469 503471 / 503473		
4-3-2	温度上昇 Temperature Rise	コネクタを嵌合させ、最大許容電流を通電し、コネクタの温度上昇分を測定する。(UL498) Mate connector and measure the temperature rise of contact when the maximum rated current is passed.(UL 498)		温度上昇 Temperature Rise	30 °C MAX.
4-3-3	耐振動性 Vibration	DC 1mA 通電状態にて、嵌合軸を含む互いに垂直な 3方向に 掃引割合 10~55~10 Hz/分、全振幅 1.52mm の振動を各2時間 加える。 (MIL-STD-202 試験法 201) Mate connectors and subject to the following vibration conditions, for a period of 2 hours in each of 3 mutually perpendicular axes, passing DC 1mA during the test. Amplitude : 1.52mm P-P Frequency : 10~55~10 Hz in 1 minute. Duration : 2 hours in each X.Y.Z.axes. (MIL-STD-202 Method 201)		外観 Appearance	異状なきこと No Damage
				接触抵抗 Contact Resistance	80 milliohms MAX.
				瞬断 Discontinuity	1 microsecond MAX.

REVISE ON PC ONLY

A

SEE SHEET 1 OF 15

TITLE:

3.7 MULTIPLE CONNECTOR SERIES

製品仕様書

THIS DOCUMENT CONTAINS INFORMATION THAT IS PROPRIETARY TO MOLEX INC. AND SHOULD NOT BE USED WITHOUT WRITTEN PERMISSION

REV.

DESCRIPTION

DOCUMENT NUMBER

PS-503471-001

FILE NAME

PS503471001.doc

SHEET

5 OF 15



PRODUCT SPECIFICATION



LANGUAGE

JAPANESE
ENGLISH

項目 Item		条件 Test Condition	規格 Requirement	
4-3-4	耐衝撃性 Mechanical Shock	DC 1mA 通電状態にて、嵌合軸を含む互いに垂直な 6方向 に 490m/s ² { 50G }、作用時間 11msの衝撃を 各3回 加える。 (JIS C60068-2-27/MIL-STD-202 試験法 213) Mate connectors and subject to the following shock conditions. 3 shocks shall be applied along 3 mutually perpendicular axes, passing DC 1 mA current during the test. (Total of 18 shocks) Test pulse : Half Sine Peak value : 490 m/s ² (50 G) Duration : 11 ms (JIS C60068-2-27/MIL-STD-202 Method 213)	外観 Appearance	異常なきこと No Damage
			接触抵抗 Contact Resistance	80 milliohms MAX.
			瞬断 Discontinuity	1 microsecond MAX.
4-3-5	耐熱性 Heat Resistance	コネクタを嵌合させ、85±2°C の雰囲気中に 96時間放置後取り出し、1時間室温に 放置する。 (JIS C60068-2-2/MIL-STD-202 試験法 108) Mate connectors and expose to 85±2°C For 96 hours. Upon completion of the exposure period, the test specimens shall be conditioned at ambient room conditions for 1 hour , after which the specified measurement shall be performed. (JIS C60068-2-2/MIL-STD-202 Method 108)	外観 Appearance	異常なきこと No Damage
			接触抵抗 Contact Resistance	80 milliohms MAX
4-3-6	耐寒性 Cold Resistance	コネクタを嵌合させ、-40±3°C の雰囲気中に 96時間 放置後取り出し、1時間 室温に 放置する。(JIS C60068-2-1) Mate connectors and expose to -40±3°C for 96 hours. Upon completion of the exposure period, the test specimens shall be conditioned at ambient room conditions for 1 hour, after which the specified measurements shall be performed. (JIS C60068-2-1)	外観 Appearance	異常なきこと No Damage
			接触抵抗 Contact Resistance	80 milliohms MAX.

REVISE ON PC ONLY		TITLE: 3.7 MULTIPLE CONNECTOR SERIES	製品仕様書
A	SEE SHEET 1 OF 15		
REV.	DESCRIPTION	THIS DOCUMENT CONTAINS INFORMATION THAT IS PROPRIETARY TO MOLEX INC. AND SHOULD NOT BE USED WITHOUT WRITTEN PERMISSION	
DOCUMENT NUMBER PS-503471-001		FILE NAME PS503471001.doc	SHEET 6 OF 15



PRODUCT SPECIFICATION



LANGUAGE

JAPANESE
ENGLISH

項目 Item		条件 Test Condition	規格 Requirement	
4-3-7	耐湿性 Humidity	コネクタを嵌合させ、60±2°C、相対湿度90~95%の雰囲気中に96時間放置後取り出し、1時間室温に放置する。 (JIS C60068-2-3/MIL-STD-202 試験法 103) Mate connectors and expose to 60±2°C, relative humidity 90 to 95% for 96 hours. Upon completion of the exposure period, the test specimens shall be conditioned at ambient room conditions for 1 to 2 hours, after which the specified measurements shall be performed. (JIS C60068-2-3/MIL-STD-202 Method 103)	外観 Appearance	異常なきこと No Damage
			接触抵抗 Contact Resistance	80 milliohms MAX.
			絶縁抵抗 Insulation Resistance	4-1-2項満足のこと Must meet 4-1-2
			耐電圧 Dielectric Strength	4-1-3項満足のこと Must meet 4-1-3
4-3-8	温度サイクル Temperature Cycling	コネクタを嵌合させ、-40±3°Cに30分、+85±2°Cに30分これを1サイクルとし、5サイクル繰返す。 但し、温度移行時間は5分以内とする。 試験後1~2時間室温に放置する。 (JIS C0025) Mate connectors and subject to the following conditions for 5 cycles. Upon completion of the exposure period, the test specimens shall be conditioned at ambient room conditions for 1 to 2 hours, after which the specified measurements shall be performed. 5 cycles of : a) -40±3°C 30 minutes b) +85±2°C 30 minutes (JIS C0025)	外観 Appearance	異常なきこと No Damage
			接触抵抗 Contact Resistance	80 milliohms MAX.

REVISE ON PC ONLY		TITLE: 3.7 MULTIPLE CONNECTOR SERIES	製品仕様書
A	SEE SHEET 1 OF 15		
REV.	DESCRIPTION	THIS DOCUMENT CONTAINS INFORMATION THAT IS PROPRIETARY TO MOLEX INC. AND SHOULD NOT BE USED WITHOUT WRITTEN PERMISSION	
DOCUMENT NUMBER PS-503471-001		FILE NAME PS503471001.doc	SHEET 7 OF 15



PRODUCT SPECIFICATION



LANGUAGE

JAPANESE
ENGLISH

項目 Item		条件 Test Condition	規格 Requirement	
4-3-9	塩水噴霧 Salt Spray	コネクタを嵌合させ、35±2°Cにて5±1%重量比の塩水を48±4時間噴霧し、試験後常温で水洗いした後、常温で乾燥させる。 (JIS C60068-2-11/MIL-STD-202 試験法101) Mate connectors and expose to the following salt mist conditions. Upon completion of the exposure period, salt deposits shall be removed by a gentle wash or dip in running water, after which the specified measurements shall be performed. NaCl solution Concentration :5±1% Spray time :48±4hours Ambient temperature :35±2°C (JIS C60068-2-11/MIL-STD-202 Method 101)	外観 Appearance	著しいサビのなきこと No Damage
			接触抵抗 Contact Resistance	80 milliohms MAX.
4-3-10	耐亜硫酸ガス SO ₂ Gas	コネクタを嵌合させ、40±2°Cにて50±5ppmの亜硫酸ガス中に24時間放置する。 Mated connectors and expose to the conditions of 50±5ppm SO ₂ gas ambient temperature 40±2°C for 24 hours.	外観 Appearance	異状なきこと No Damage
			接触抵抗 Contact Resistance	80 milliohms MAX.
4-3-11	半田付け性 Solderability	端子先端より0.2mm、金具先端より0.2mmの位置まで、240±2°Cの半田に 3±0.5秒浸す Soldering Time : 3±0.5 seconds Solder Temperature : 240±2°C 0.2mm from terminal tip 0.2mm from fitting nail tip	濡れ性 Solder Wetting	浸漬面積の90%以上 90% of immersed area must show no voids, pinholes.

REVISE ON PC ONLY

A

SEE SHEET 1 OF 15

TITLE:

3.7 MULTIPLE CONNECTOR SERIES

製品仕様書

REV.

DESCRIPTION

THIS DOCUMENT CONTAINS INFORMATION THAT IS PROPRIETARY TO MOLEX INC. AND SHOULD NOT BE USED WITHOUT WRITTEN PERMISSION

DOCUMENT NUMBER

PS-503471-001

FILE NAME

PS503471001.doc

SHEET

8 OF 15



PRODUCT SPECIFICATION



LANGUAGE

JAPANESE
ENGLISH

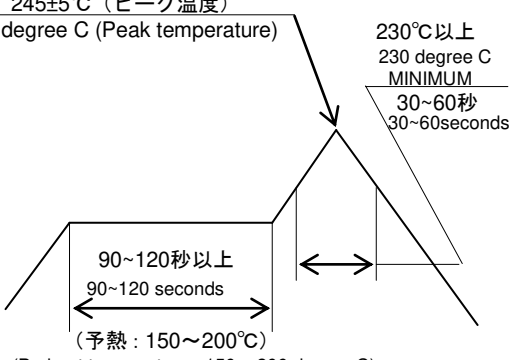
項目 Item	条件 Test Condition	規格 Requirement
4-3-12 半田耐熱性 Resistance to Soldering Heat	<p><リフロー時> 赤外線リフロー条件 <u>INFRARED REFLOW CONDITION</u> 下部条件にてリフローを2回行う。 The reflow is passed twice. 245±5°C (ピーク温度) 245±5 degree C (Peak temperature)</p>  <p>230°C以上 230 degree C MINIMUM 30~60秒 30~60seconds</p> <p>90~120秒以上 90~120 seconds (予熱 : 150~200°C) (Preheat temperature : 150 - 200 degree C)</p> <p><u>温度条件グラフ</u> <u>TEMPERATURE CONDITION GRAPH</u> (リードはんだ付け部温度) (TEMPERATURE ON SOLDER TAIL OF CONNECTOR) 注記 : 本リフロー条件に関しては、リフロー装置及び基板等により条件が異なりますので、事前にリフロー評価の確認をお願いします。 NOTE: Please check the reflow soldering condition by your own devices beforehand. Because the condition change by the soldering devices, p.c.board, and so on.</p> <p><手半田時> 端子先端より0.2mm、金具先端より0.2mmの位置まで、350±10 °Cの半田ゴテにて最大5秒間加熱する。但し異常な加圧の無いこと。 Soldering Time : 5 seconds MAX. Solder Temperature : 350±10°C 0.2mm from terminal tip 0.2mm from fitting nail tip Without too much pressure to the terminal pin and fitting nail.</p>	外 観 Appearance 端子ガタ、割れ等 異状なきこと No Damage

() : 参考規格 Reference Standard
 { } : 参考単位 Reference Unit

REVISE ON PC ONLY		TITLE:	
A	SEE SHEET 1 OF 15	3.7 MULTIPLE CONNECTOR SERIES	
REV. DESCRIPTION		製品仕様書	
DOCUMENT NUMBER PS-503471-001		THIS DOCUMENT CONTAINS INFORMATION THAT IS PROPRIETARY TO MOLEX INC. AND SHOULD NOT BE USED WITHOUT WRITTEN PERMISSION	FILE NAME SHEET PS503471001.doc 9 OF 15



【5. 外観形状・寸法・材質 PRODUCT SHAPE, DIMENSIONS, MATERIALS】

図面参照 Refer to the drawing.

【6. 環境指令への適合 COMPLIANCE WITH ENVIRONMENTAL DIRECTIVE】

ELV及びRoHS適合品
ELV and RoHS compliant.

【7. 使用上の注意事項 INSTRUCTION UPON USAGE】

- 本製品のプラスチック部に黒点等が確認される場合や色合いが異なる場合（経年変化によるハウジングの変色を含む）がありますが、製品性能には影響ございません。
There is no influence in the product performance though the black spot etc. might be confirmed to the plastic part of this product and the shade might be different (discoloration by secular distortion etc.).
- 本製品は錫めっきを使用しているため、外観に摺動痕がつく場合が御座いますが、製品性能に影響はありません。
The wound of friction might adhere to externals because the tin plating is used for the tail and nail. But there is no influence in the product performance.
- 梱包品の保管期限が過ぎた場合は外観、半田付け性を確認の上ご使用下さい。
Please use it after confirming externals and soldering when the storage limitation of the packing goods passes.
- 本リフロー条件に関しては、温度プロファイル、半田ペースト、大気、N2リフロー、基板などにより条件が異なりますので事前に実装評価(リフロー評価)を必ず実施願います。実装条件によっては、製品性能に影響を及ぼす場合があります。
Please investigate the mounting condition (reflow soldering condition) on your own devices beforehand. The mounting conditions may change due to the soldering temperature, soldering paste, air reflow machine, Nitrogen reflow machine, and the type of printed circuit board. The different mounting conditions may have an influence on the product's performance.
- 実装性能（平坦度）は、実装基板の反りの影響を含まないものと致します。基板の反りはコネクタ両端部を基準とし、コネクタ中央部にて Max0.02mmとして下さい。
The mounting specification for coplanarity does not include the influence of warpage of the printed circuit board. The warpage of the printed circuit board should be a maximum of 0.02mm if measuring from one connector edge to the other.
- 本製品の一般性能確認はリジット基板にて実施おります。フレキシブル基板等の特殊な基板へ実装する場合は事前に実装確認等を行った上でご使用願います。
The product performance was tested using rigid printed circuit board. In case the product needs to be reflowed onto flexible circuit board, please conduct a reflow test on the flexible circuit board in advance.

REVISE ON PC ONLY		TITLE:	
A	SEE SHEET 1 OF 15	3.7 MULTIPLE CONNECTOR SERIES	
	REV.	DESCRIPTION	製品仕様書
		THIS DOCUMENT CONTAINS INFORMATION THAT IS PROPRIETARY TO MOLEX INC. AND SHOULD NOT BE USED WITHOUT WRITTEN PERMISSION	
DOCUMENT NUMBER		FILE NAME	SHEET
PS-503471-001		PS503471001.doc	10 OF 15
EN-37-1(019)			



PRODUCT SPECIFICATION



LANGUAGE

JAPANESE
ENGLISH

7. 本製品は端子先端部に、カット面がある為に端子先端部の実装性(基板への半田付け性)は、端子側面・後側に比べて悪くなります。しかし、側面及び後側においてフィレットが形成されていれば、機能及び強度に問題は
ありません。

Because this product has a cutoff area on the tip of the terminal, the solderability performance in this area is not as good as compared to the side/back of the terminal. However, by building a good soldering fillet at the side/back of the terminal, there will be no issue on either the product function or the printed circuit board retention force.

8. 半田実装部の未半田は、ターミナル脱落、ピン間ショート、ターミナル座屈、またコネクタの基板からの外れが懸念されます。従って全てのターミナルテール部及び、ネイル部に半田付けを行って下さい。

If you leave any soldering area on this product open, there may be the possibility of a missing terminal short circuiting between pins, terminal buckling or the potential for the connector to come off of the printed circuit board. Therefore, please solder all of the terminals and fitting nails on the printed circuit board.

9. 本製品をご使用時に取り付けられた電線・プリント基板の共振や、機器の回転構造や可動部分の動作によりコネクタ嵌合部（接点部）が常に動いてしまう状態での御使用は避けて下さい。接触部の摺動磨耗等による接触不良の原因となります。従って、機器内で電線・プリント基板を固定し、共振を抑える等の処置をお願い致します。

Please do not use the connector in a condition where the wire, the printed circuit board, or the contact area is experiencing a sympathetic vibration of wires and printed circuit board, and constant movement of devices. This may cause a defect in the contact due to the contact area being worn down. Therefore, please fix wires and printed circuit board on the chassis, and reduces sympathetic vibration.

10. 基板実装前後に端子、補強金具に触らないでください。

Please do not touch the terminals and fitting nails before or after reflowing the connector onto the printed circuit board.

11. コネクタ嵌合状態で基板の持ち運び等コネクタに負荷が掛かる作業は行わないようにしてください。コネクタ破損等の原因となる場合があります。

Please do not do work that the load hangs in the connector like the carrying of the substrate etc. with the connector engages. There is a case where it causes the connector damage etc.

12. 基板実装後に基板を直接積み重ねない様に注意してください。

Please do not stack the printed circuit board directly after mounted the connector on it.

13. コネクタは極力嵌合軸に沿って挿入抜去を行ってください。斜め挿抜はコネクタ破損等の原因になる場合があります。

Please insert and withdraw the connector as much as possible along the engagement axis, or there is a case where it causes the connector damage etc.

14. 実装後において半田ごてによる手修正を行う際は、必ず仕様書掲載の条件以内で行って下さい。条件を超えて実施した場合、端子の抜け、接点ギャップの変化、モールドの変形、溶融等、破損の原因になります。

When conducting manual repairs using a soldering iron, please follow the soldering conditions shown in the product specification. If the conditions in the product spec are not followed, it may cause the terminals to fall off, a change in the contact gap, a deformation of the housing, melting of the housing, and damage the connector.

REVISE ON PC ONLY

A

SEE SHEET 1 OF 15

TITLE:

3.7 MULTIPLE CONNECTOR SERIES

製品仕様書

THIS DOCUMENT CONTAINS INFORMATION THAT IS PROPRIETARY TO MOLEX INC. AND SHOULD NOT BE USED WITHOUT WRITTEN PERMISSION

REV.

DESCRIPTION

DOCUMENT NUMBER

PS-503471-001

FILE NAME

PS503471001.doc

SHEET

11 OF 15



PRODUCT SPECIFICATION



LANGUAGE

JAPANESE
ENGLISH

- 1 5. 半田こてによる手修正を行なう際、過度の半田やフラックスを使用しないで下さい。半田上がりやフラックス上がりにより接触、機能不良に至る場合があります。
When conducting manual repairs using a soldering iron, please do not use more solder and flux than needed. This may cause solder wicking and flux wicking issues, and it will eventually cause a contact defect and functional issues.
- 1 6. リフロー条件によっては、樹脂部の変色や端子めっき部にヨリが発生する場合がありますが、製品性能に影響はございません。
Depending on the reflow conditions, there may be the possibility of a color change in the housing. However, this color change does not have any effect on the product's performance.
- 1 7. 実装機によってコネクタに負荷が加わると変形、破損する場合がありますので事前にご確認下さい。
If there is accidental contact with the connector while it is going through the reflow machine, there may be deformation or damage caused to the connector. Please check to prevent this.
- 1 8. コネクタのみで基板を支えることは避け、コネクタ以外での基板固定対策を行ってください。
Please do not use the connector alone to provide mechanical support for the printed circuit board (PCB). Please ensure that there is a fixed structure on the phone chassis or other component support for the PCB.
- 1 9. 嵌合後、コネクタピッチ方向、スパン方向及び回転方向への負荷がかかるような動作またはセットはしないでください。コネクタ破壊やはんだクラックを引き起こします。
After mated the connector, please do not allow the printed circuit boards to apply pressure on the connector in either the pitch direction or the span direction. It may cause damage to the connector and may crack the soldering.
- 2 0. 本製品及び加工工程品（仕掛品）や加工品（ハーネス等）の梱包及び輸送・保管時にはコネクタに負荷が加わらないようご注意ください。変形、破損などの原因となり、コネクタの性能不良の原因となります。
Please try to prevent any external forces or shock from being applied to the connector while the cable assembly is in process, when it is being packaged, or while it is in transportation. This may cause deformation and damage to the connector and cause a defect in the product's performance.
- 2 1. ハーネス加工品及びコネクタ嵌合後の電線の引き回しの際、引張りによる力が加わりますと、接点部、結線部（圧着部）やロック部（端子ロック部）が損傷を受け、接触不良の原因となります。電線の引回し配線をされる場合、コネクタに無理な外力が加わらないように、電線に緩みを持たせ、余裕を持たせる処置をして下さい。
The cable assembly should not have a constant stress or pulling force applied on it when it is in the mated condition. This phenomenon may damage the contact area or wiring area (crimping). Therefore, when designing the wire positioning, please ensure that there is enough length of wire to avoid stress on the connector.
- 2 2. コネクタに適用できる電線は、原則として錫メッキつき付軟銅撚り線です。その他の電線の使用については別途ご確認ください。
The applicable wire for this connector, in principle, is tin-plated copper stranded wire. Please consult us and evaluate it in advance when using other wires.

	REVISE ON PC ONLY	TITLE:		
A	SEE SHEET 1 OF 15	3.7 MULTIPLE CONNECTOR SERIES		製品仕様書
REV.	DESCRIPTION	THIS DOCUMENT CONTAINS INFORMATION THAT IS PROPRIETARY TO MOLEX INC. AND SHOULD NOT BE USED WITHOUT WRITTEN PERMISSION		
DOCUMENT NUMBER PS-503471-001		FILE NAME	SHEET	
		PS503471001.doc	12 OF 15	
EN-37-1(019)				



2 3. プラグハウジング (503473-0200) に端子 (503485-0000) を挿入する際、図1に示した正規の方向から端子が突き当たるまで挿入して下さい。又、挿入後軽く電線を引張って端子が抜け出さないか確認下さい。
 When inserting the terminal (503485-0000) into the receptacle housing (503473-0000), please ensure that the terminal is inserted completely and touches the end of the receptacle housing. Please insert the terminal in the correct direction as showing in figure 1. Also, please pull the wire lightly after inserting the terminal to ensure that the terminal is fully inserted and can not be pulled out.

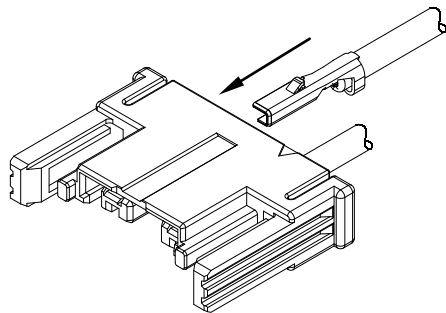

<図1 端子挿入方向>

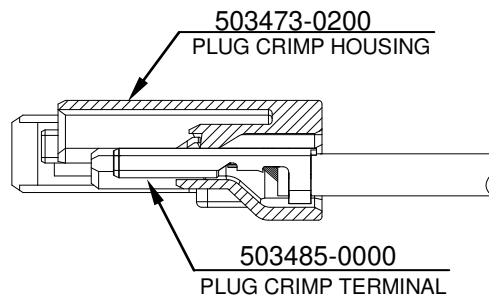

<図2 端子装着状態>

- 2 4. コネクタの嵌合を取り外す際は、必ずロックを解除して行って下さい。
 電線はまとめて軽く掴み、指全体で確実にロックを解除し、取り出して下さい。
 Please detach the connector lock before unmating the connector.
 Please secure all the wires together softly, release the lock completely with a finger, and then unmate the connector.
- 2 5. 治具等を使用し、圧着端子を抜いた場合には、ランスが変形し強度が低下し端子を再装着後の端子保持力が極端に低下します。そのため、圧着端子のリペアの際には新しいハウジングを必ず使用して下さい。
 When extracting a crimp terminal from the housing using a jig, it may deform the housing lance and therefore reduce the terminal retention force after re-inserting of the terminal. Therefore, please ensure to use a new housing after repairing the crimp terminals.
- 2 6. 本製品をご使用時には、1 PIN当りの定格以上の電流を複数の回路に分岐しての使用は避けて下さい。
 When using this product, please ensure that the specification for rated current per circuit is followed. Do not allow the sum of the current used on several circuits to exceed the maximum allowable current.

REVISE ON PC ONLY		TITLE:	
A	SEE SHEET 1 OF 15	3.7 MULTIPLE CONNECTOR SERIES	
	REV.	DESCRIPTION	製品仕様書
		THIS DOCUMENT CONTAINS INFORMATION THAT IS PROPRIETARY TO MOLEX INC. AND SHOULD NOT BE USED WITHOUT WRITTEN PERMISSION	
DOCUMENT NUMBER		FILE NAME	SHEET
PS-503471-001		PS503471001.doc	13 OF 15



27. 活電状態の電気回路で、挿入、抜去ができることを前提に作られていません。スパーク等による危険の発生、性能不良につながりますので、活電状態での挿入、抜去はしないで下さい。This product is not designed for the mating and unmating of the connectors to be performed under the condition of an active electrical circuit. It may cause a spark and product defect if the connectors are mated and unmated in this way.
28. ハーネス加工時及びハーネス品梱包時にハウジングとロックの隙間に電線が絡まない様に注意して下さい。また、ハウジングとロックの隙間に電線が絡んだ場合には電線を無理矢理引張らないで下さい。ロックが変形する場合があります。電線が絡んだ際にはロックに負荷が掛からない様注意して外して下さい。Please note that the electric wire doesn't twine round the space of the lock with the housing when the harness is processed and the harness goods are packed. Please do not hitch forcibly when the electric wire twines round the space between the housing and the lock. There is a case where the lock is transformed. Please remove externals where the load doesn't hang in the lock carefully when the electric wire twines.

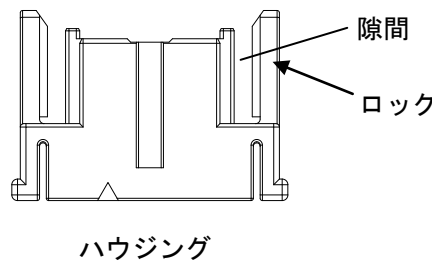

A	REVISE ON PC ONLY	SEE SHEET 1 OF 15	TITLE: 3.7 MULTIPLE CONNECTOR SERIES	
	REV.		DESCRIPTION	製品仕様書 THIS DOCUMENT CONTAINS INFORMATION THAT IS PROPRIETARY TO MOLEX INC. AND SHOULD NOT BE USED WITHOUT WRITTEN PERMISSION
DOCUMENT NUMBER PS-503471-001			FILE NAME PS503471001.doc	SHEET 14 OF 15



PRODUCT SPECIFICATION



LANGUAGE
JAPANESE
ENGLISH

REV.	REV. RECORD	DATE	EC NO.	WRITTEN:	CH'K:
A	RELEASED	2009/7/24	J2010-0155	H.KOBAYASHI	S.SATO

A	REVISE ON PC ONLY	TITLE: 3.7 MULTIPLE CONNECTOR SERIES 製品仕様書
	SEE SHEET 1 OF 15	
REV.	DESCRIPTION	THIS DOCUMENT CONTAINS INFORMATION THAT IS PROPRIETARY TO MOLEX INC. AND SHOULD NOT BE USED WITHOUT WRITTEN PERMISSION
DOCUMENT NUMBER PS-503471-001		FILE NAME PS503471001.doc
		SHEET 15 OF 15