

**SMA FEMALE - SMB MALE STRAIGHT ADAPTER**

**R191.201.007**

Série : ADAPT

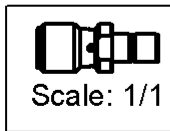
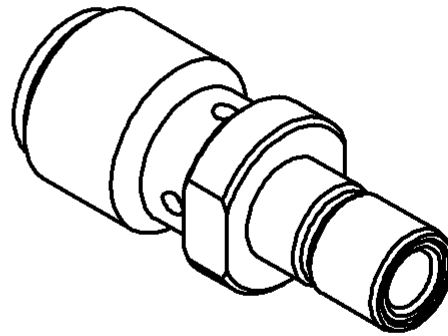
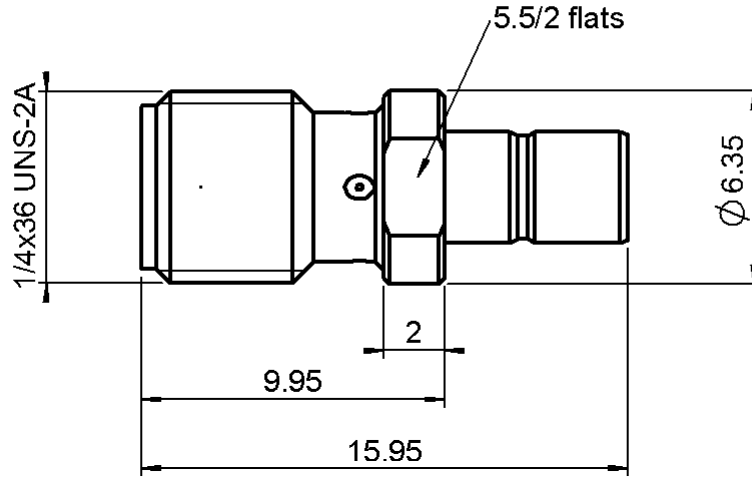

All dimensions are in mm.

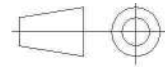

COMPONENTS	MATERIALS	PLATINGS (µm)
BODY	BRASS	BBR 2
CENTER CONTACT	BERYLLIUM COPPER	GOLD 1.3 OVER COPPER 2.5
OUTER CONTACT	-	-
INSULATOR	PTFE	-
GASKET	-	-
OTHERS PARTS	-	-
-	-	-
-	-	-

Issue : 0840 A

In the effort to improve our products, we reserve the rights to make changes judged to be necessary.



**SMA FEMALE - SMB MALE STRAIGHT ADAPTER**

**R191.201.007**

Série : ADAPT

**PACKAGING**

Standard	Unit	Other
<b>1</b>		<b>Contact us</b>

**SPECIFICATION**

**ELECTRICAL CHARACTERISTICS**

Impedance		<b>50</b> Ω
Frequency		<b>0-4</b> GHz
VSWR	<b>NA</b> +	<b>0,0000</b> x F(GHz) Maxi
Insertion loss		<b>NA</b> √F(GHz) dB Maxi
RF leakage	- (	- F(GHz)) dB Maxi
Voltage rating		<b>335</b> Veff Maxi
Dielectric withstanding voltage		<b>1000</b> Veff mini
Insulation resistance		<b>1000</b> MΩ mini

**ENVIRONMENTAL**

Operating		<b>-65/+125</b> °C
Hermetic seal		<b>NA</b> Atm.cm3/s
Panel leakage		<b>NA</b>

**MECHANICAL CHARACTERISTICS**

Center contact retention		
Axial force – Mating end		<b>10</b> N mini
Axial force – Opposite end		<b>10</b> N mini
Torque		<b>2.8</b> N.cm mini
Recommended torque		
Mating	<b>SMA-</b>	<b>0</b> N.cm
	<b>SMB</b>	<b>0</b> N.cm
	-	<b>0</b> N.cm
Panel nut		<b>NA</b> N.cm
Mating life		<b>500</b> Cycles mini
Weight		<b>0,0000</b> g

**OTHERS CHARACTERISTICS**

Issue : 0840 A

In the effort to improve our products, we reserve the rights to make changes judged to be necessary.



**RADIALL**®