

This document is the property of Amphenol Corporation and is delivered on the express condition that it is not to be disclosed, reproduced or used, in whole or in part, for manufacture or sale by anyone other than Amphenol Corporation without its prior consent, & that no right is granted to disclose or to use any information in this document.

CUSTOMER DRAWING

REVISIONS				
SYM	ECN	DESCRIPTION	DATE	APPROVED
16	CD2778	UPDATE THE PACKING TRAY	Aug.02,2021	YH
17	CD2785	UPDATE THE SHEET 4 :ADDITIONAL NOTES	Aug.05,2021	YH
18	ELX-CD-44629-1	ADD 123.6MM MYLAR OPTION	May.05,2022	YH

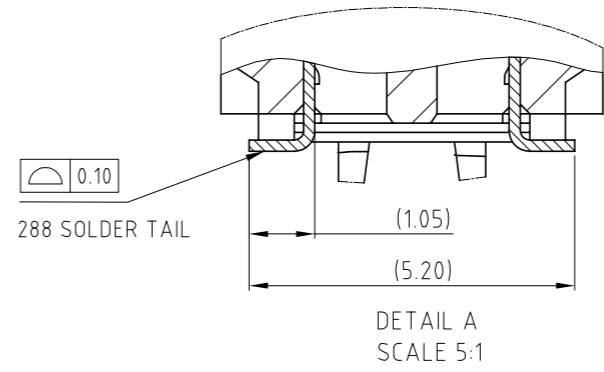
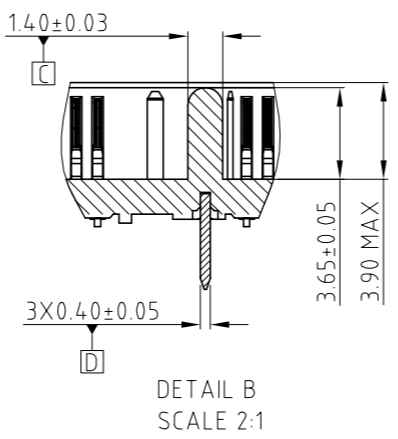
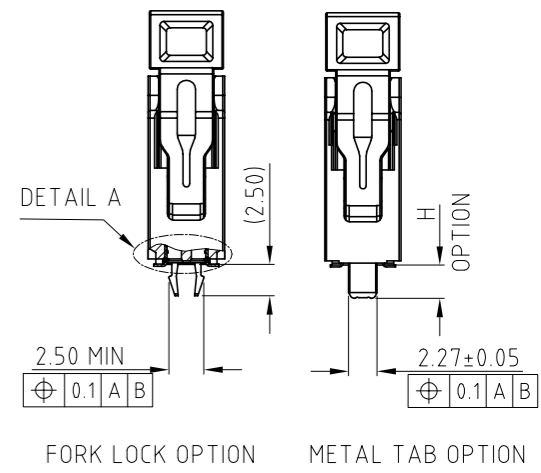
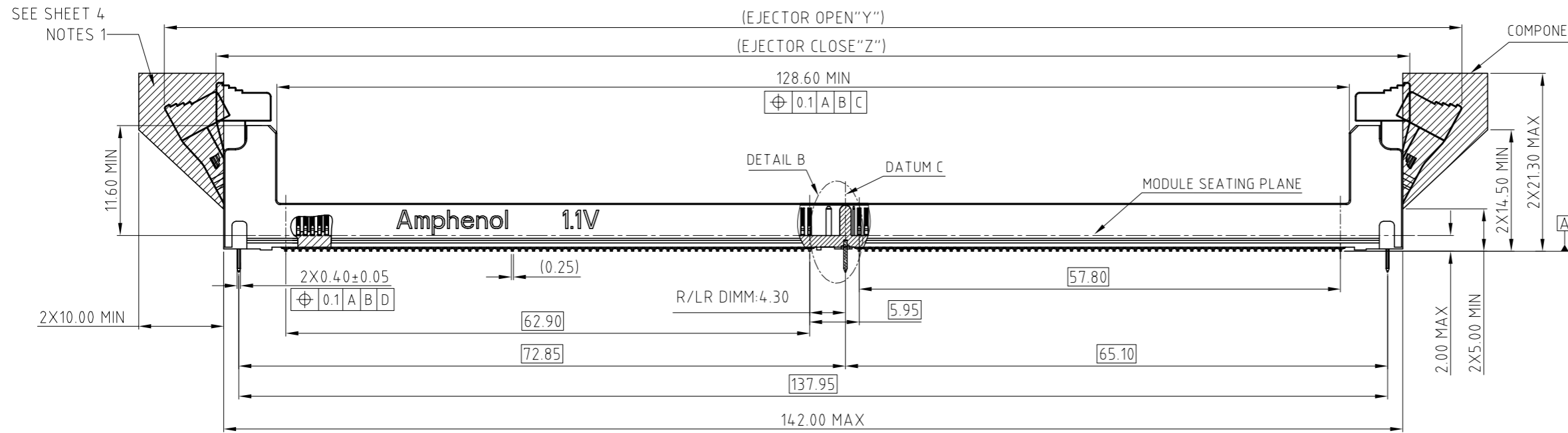
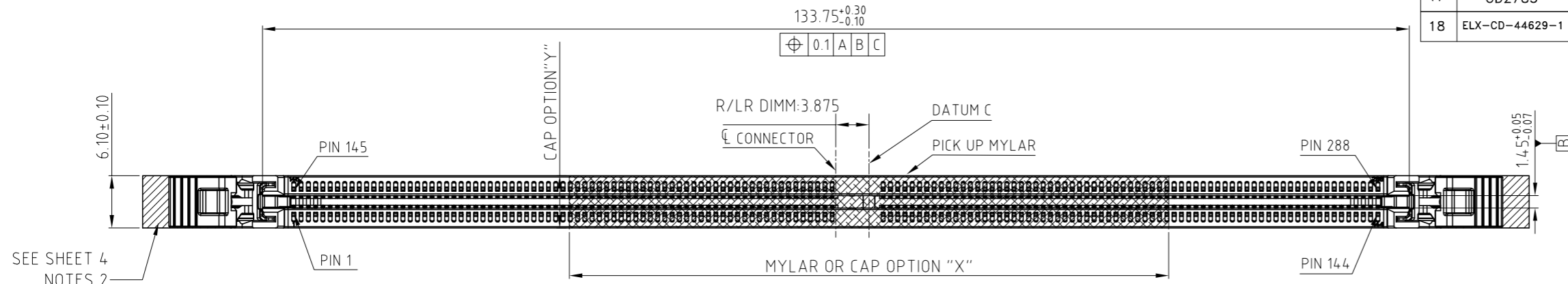

ITEM	EJECTOR OPEN DIMENSION "Y"	EJECTOR CLOSE DIMENSION "Z"	EJECTOR FIGURE
STANDARD LATCH	156.00	144.00	

UNLESS OTHERWISE SPECIFIED TOLERANCES		APPROVAL	DATE	Amphenol
.X	+/- 0.35	DRAWN	Kellen.Yang	
.XX	+/- 0.25	CHECKED		
.XXX	+/- 0.15	CHECKED		
FRACTIONS	+/- 3'	DRAWING FILE : DRAWING\DDR\DDR504XXXXXXX		TITLE
ANGLES	+/-			DDR5 288P R/LR DIMM CONNECTOR
FOR MATERIALS AND FINISHES SEE NOTES		ANGLE OF PROJECTION		SIZE
REMOVE SHARP EDGES				DRAWING NO.
DIMENSIONS				A3 C
U.S.	INCHES			SCALE
(METRIC)	(MM)			NONE
				REV.
				18
				SHEET 1 OF 6

This document is the property of Amphenol Corporation and is delivered on the express condition that it is not to be disclosed, reproduced or used, in whole or in part, for manufacture or sale by anyone other than Amphenol Corporation without its prior consent, & that no right is granted to disclose or to use any information in this document.

CUSTOMER DRAWING

REVISIONS				
SYM	ECN	DESCRIPTION	DATE	APPROVED
		SEE SHEET 1		

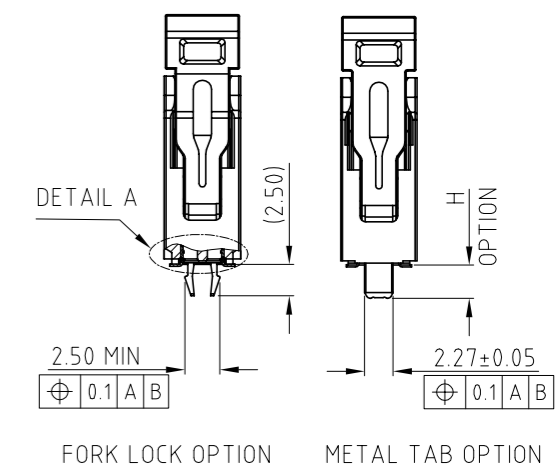
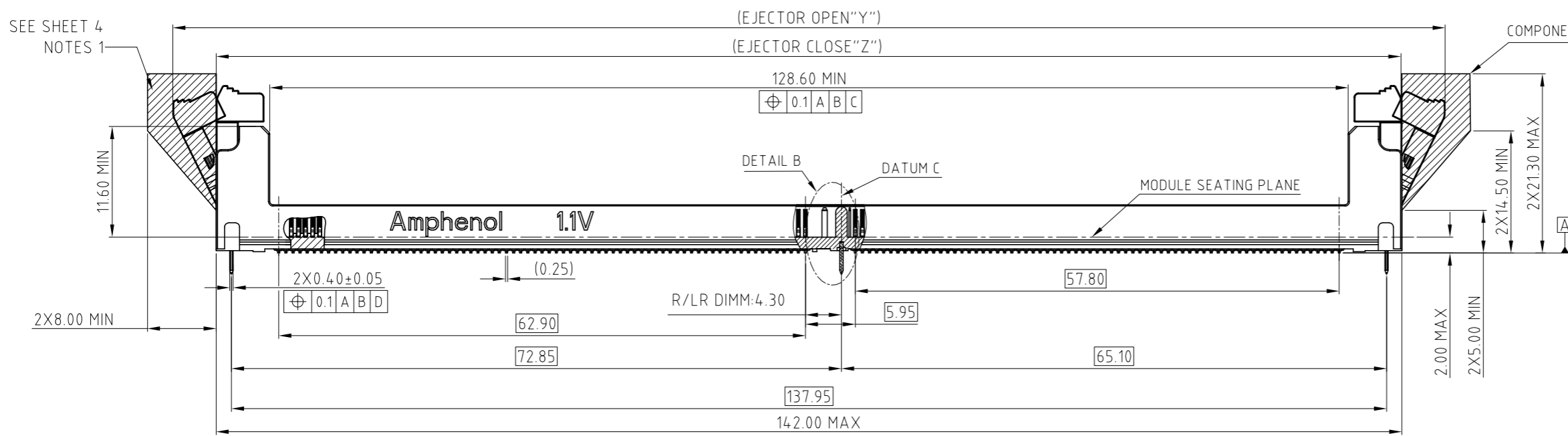
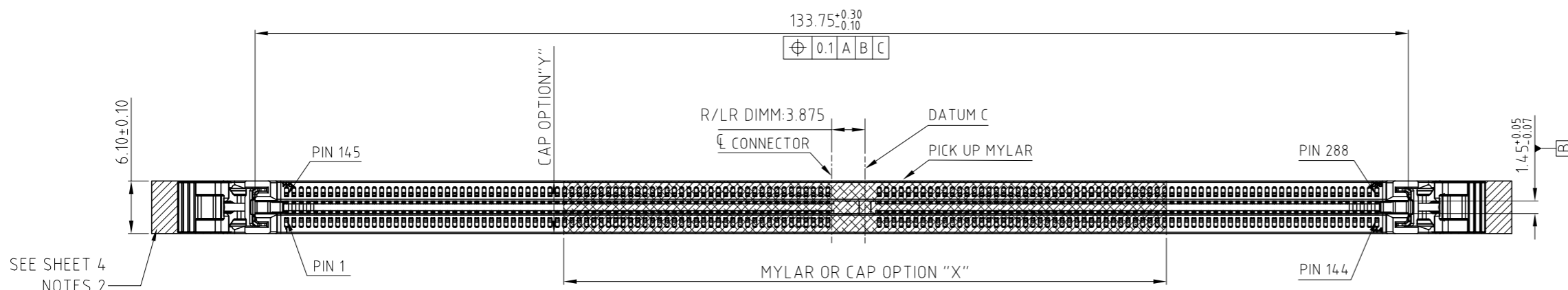

ITEM	EJECTOR OPEN DIMENSION "Y"	EJECTOR CLOSE DIMENSION "Z"	EJECTOR FIGURE
SHORT LATCH	152.00	142.00	

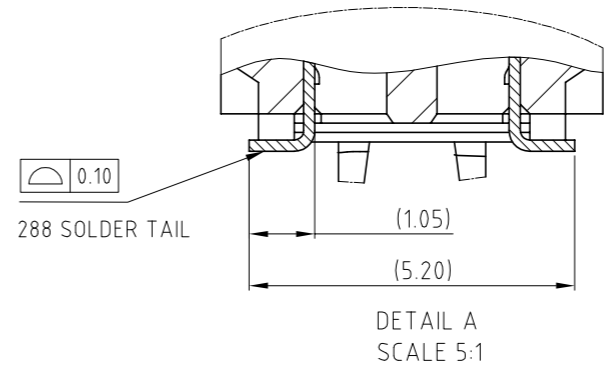
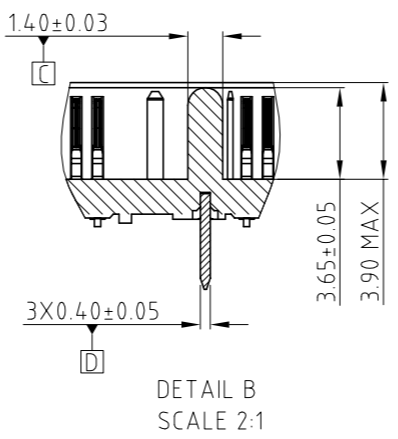

UNLESS OTHERWISE SPECIFIED TOLERANCES		APPROVAL	DATE	Amphenol
.X	+/-	0.35		
.XX	+/-	0.25		
.XXX	+/-	0.15		
FRACTIONS +/-				
ANGLES +/-		3°		
FOR MATERIALS AND FINISHES SEE NOTES		DRAWING FILE : DRAWING\DDR\DDR504XXXXXXX		TITLE DDR5 288P R/LR DIMM CONNECTOR
REMOVE SHARP EDGES		ANGLE OF PROJECTION		SIZE DRAWING NO. REV.
DIMENSIONS				A3 C DDR5-04-X-X-X-XXX-X-X 18
U.S.	INCHES			SCALE NONE SHEET 2 OF 6
(METRIC)	(MM)			

This document is the property of Amphenol Corporation and is delivered on the express condition that it is not to be disclosed, reproduced or used, in whole or in part, for manufacture or sale by anyone other than Amphenol Corporation without its prior consent, & that no right is granted to disclose or to use any information in this document.

CUSTOMER DRAWING



REVISIONS				
SYM	ECN	DESCRIPTION	DATE	APPROVED
		SEE SHEET 1		

DDR5 MODULE
MORE INFORMATION REFER TO JEDEC MO-329

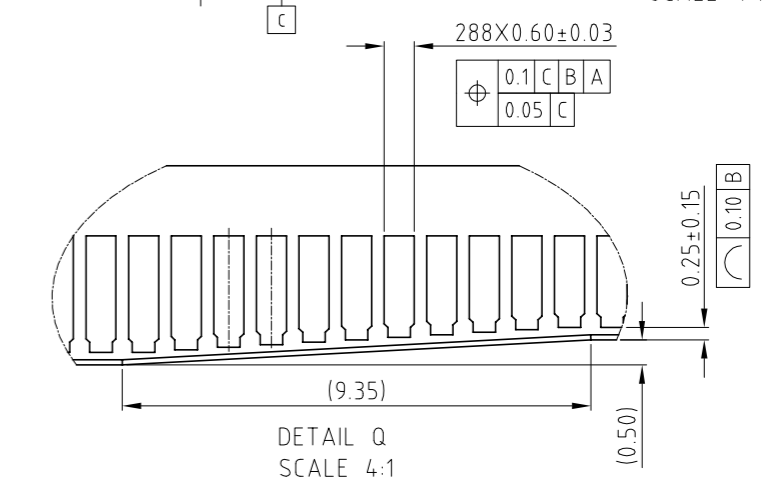
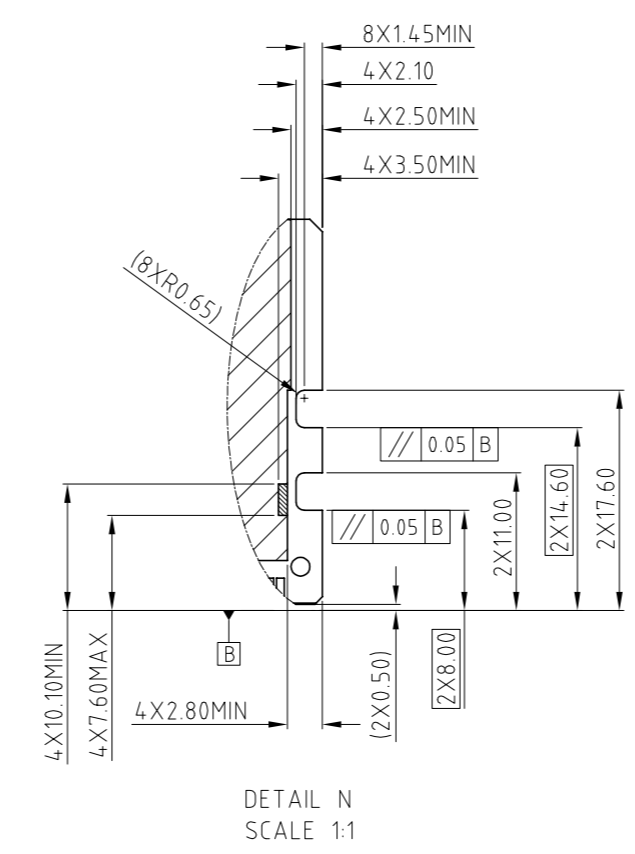
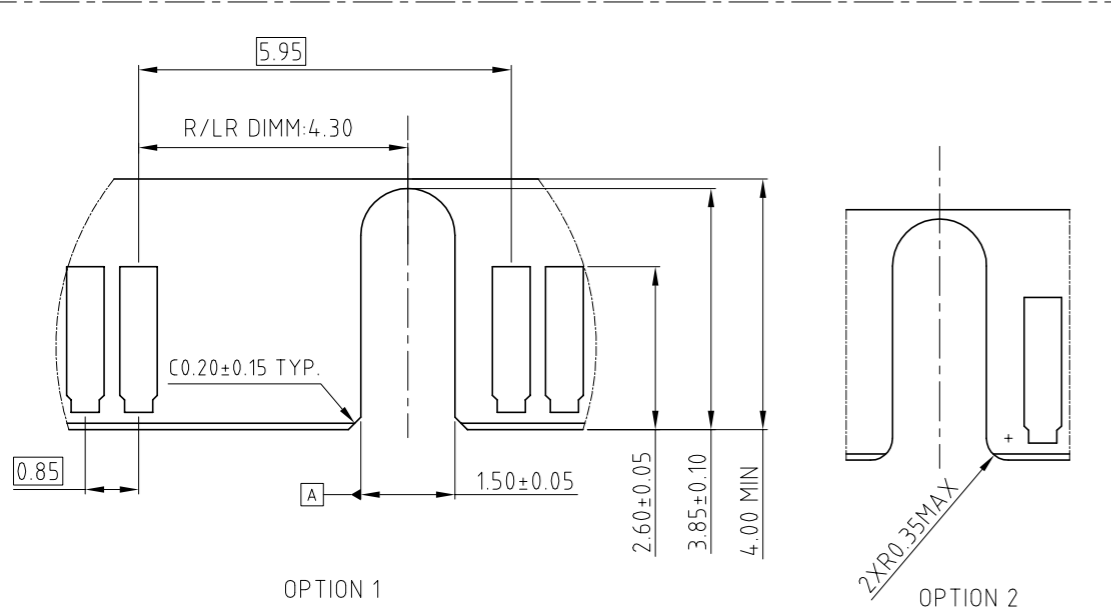
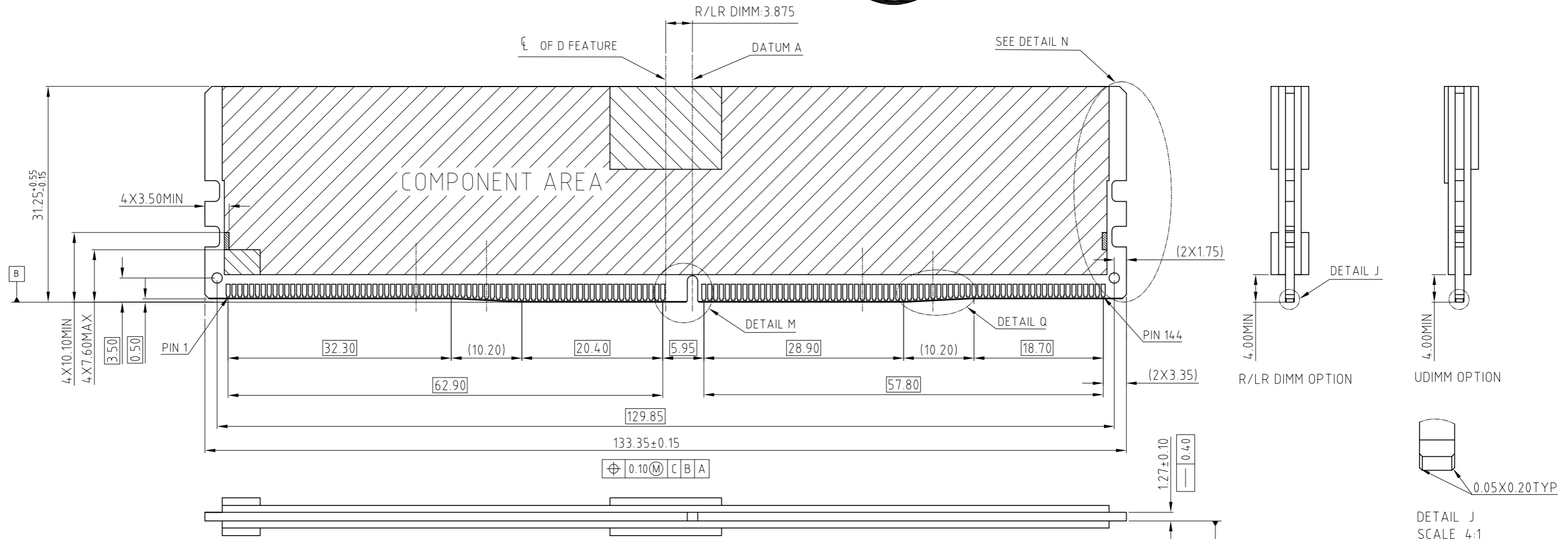

UNLESS OTHERWISE SPECIFIED TOLERANCES		APPROVAL	DATE	Amphenol
.X	+/-	U.S.	METRIC	
.XX	+/-	0.35	0.25	
.XXX	+/-	0.25	0.15	
FRACTIONS	+/-		3°	
ANGLES	+/-			
FOR MATERIALS AND FINISHES SEE NOTES		DRAWING FILE : DRAWING\DDR\DDR504XXXXXXX		TITLE
REMOVE SHARP EDGES		ANGLE OF PROJECTION		DDR5 288P R/LR DIMM CONNECTOR
DIMENSIONS				SIZE DRAWING NO.
U.S.	INCHES			A3 C DDR5-04-X-X-X-XXX-X-X
(METRIC)	(MM)			REV. 18
		SCALE	NONE	SHEET 3 OF 6

This document is the property of Amphenol Corporation and is delivered on the express condition that it is not to be disclosed, reproduced or used, in whole or in part, for manufacture or sale by anyone other than Amphenol Corporation without its prior consent, & that no right is granted to disclose or to use any information in this document.



CUSTOMER DRAWING

REVISIONS				
SYM	ECN	DESCRIPTION	DATE	APPROVED
		SEE SHEET 1		

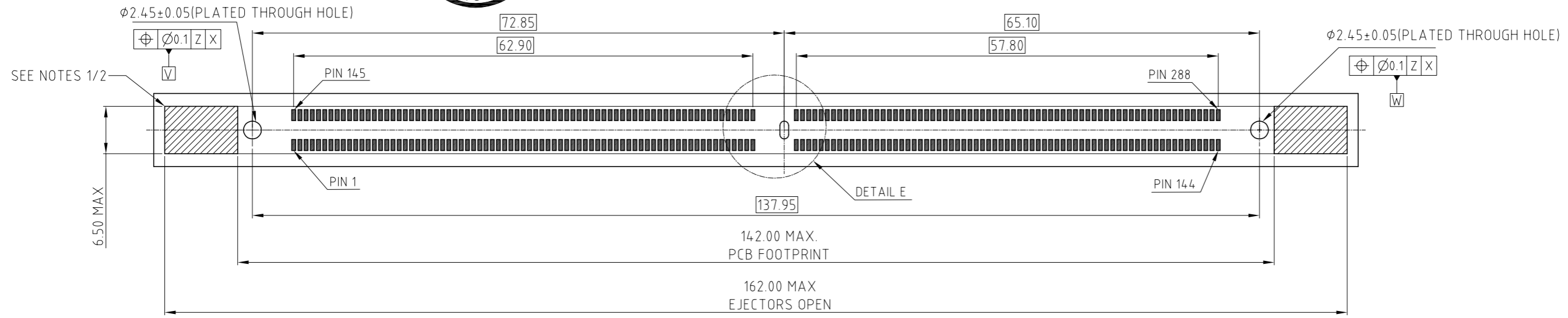

RECOMMENDED PCB FOOTPRINT (OPTION 1)

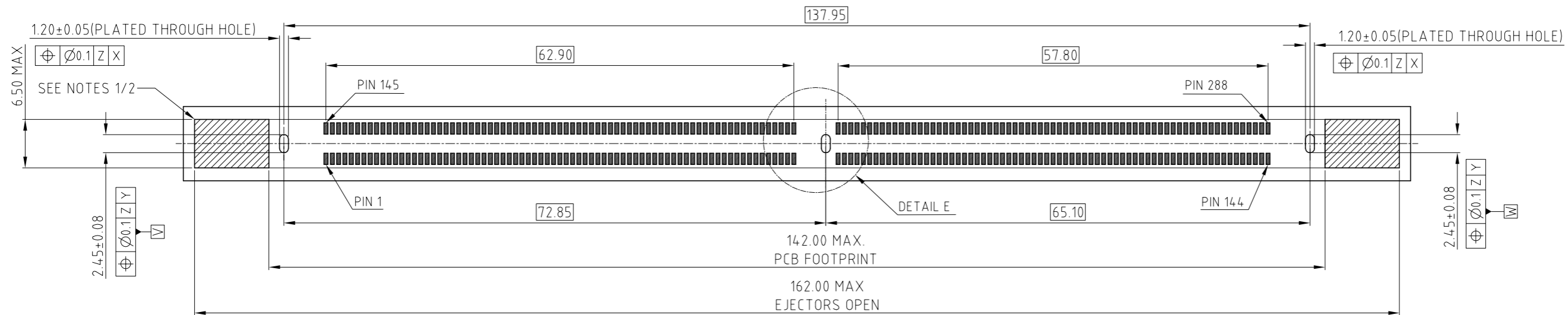

RECOMMENDED PCB FOOTPRINT (OPTION 2)

ADDITIONAL NOTES:

- KEEP OUT CROSS HATCH IS RESERVED FOR SOCKET EJECTORS AT BOTH ENDS.
- KEEP OUT ZONE IS HEIGHT LIMITED PER NOTE 1.
- RECOMMENDED STENCIL THICKNESS:

REFLOW CONDITION	THICKNESS OF STENCIL
AIR	0.18MM MIN
NITROGEN	0.18MM MIN
REWORK	0.20MM MIN

RECOMMENDED PCB LAYOUT
MORE INFORMATION REFER TO JEDEC SO-023

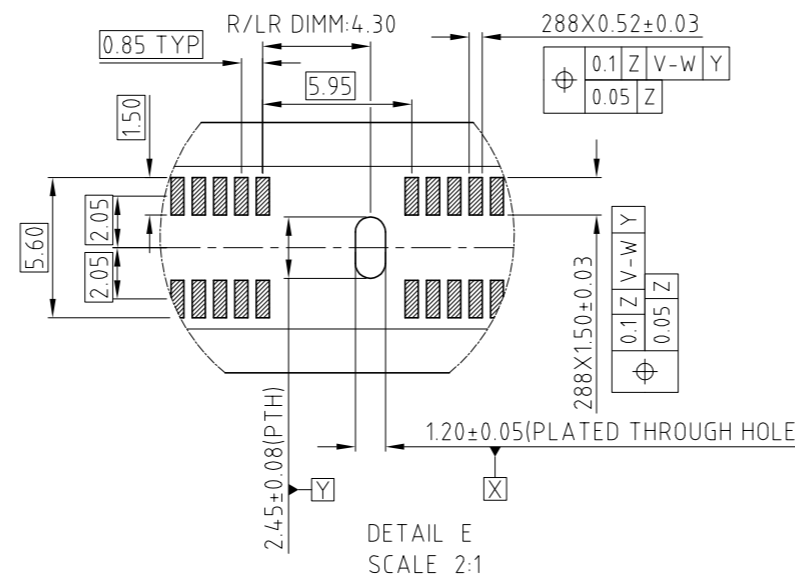

DETAIL E
SCALE 2:1

UNLESS OTHERWISE SPECIFIED TOLERANCES		APPROVAL	DATE	Amphenol
U.S.	METRIC	DRAWN	May.05,2022	
.X +/-	0.35	CHECKED		TITLE DDR5 288P R/LR DIMM CONNECTOR
.XX +/-	0.25	CHECKED		
.XXX +/-	0.15			DRAWING FILE : DRAWING\DDR\DDR504XXXXXXX
FRACTIONS +/-				
ANGLES +/-	3°			ANGLE OF PROJECTION
FOR MATERIALS AND FINISHES SEE NOTES				
REMOVE SHARP EDGES				SIZE A3
DIMENSIONS				
U.S. (METRIC)	INCHES (MM)			DRAWING NO. DDR5-04-X-X-X-XXX-X-X
				REV. 18
				SCALE NONE
				SHEET 4 OF 6

This document is the property of Amphenol Corporation and is delivered on the express condition that it is not to be disclosed, reproduced or used, in whole or in part, for manufacture or sale by anyone other than Amphenol Corporation without its prior consent, & that no right is granted to disclose or to use any information in this document.

CUSTOMER DRAWING



REVISIONS				
SYM	ECN	DESCRIPTION	DATE	APPROVED
		SEE SHEET1		

PACKING TRAY DRAWING

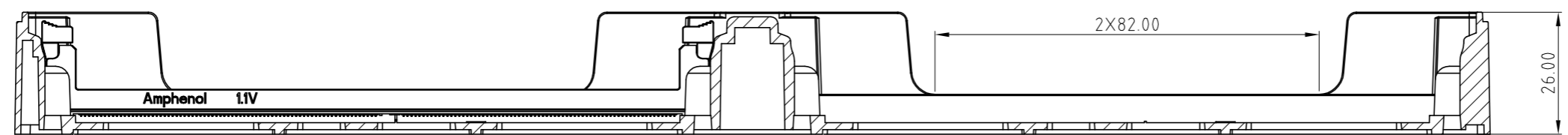
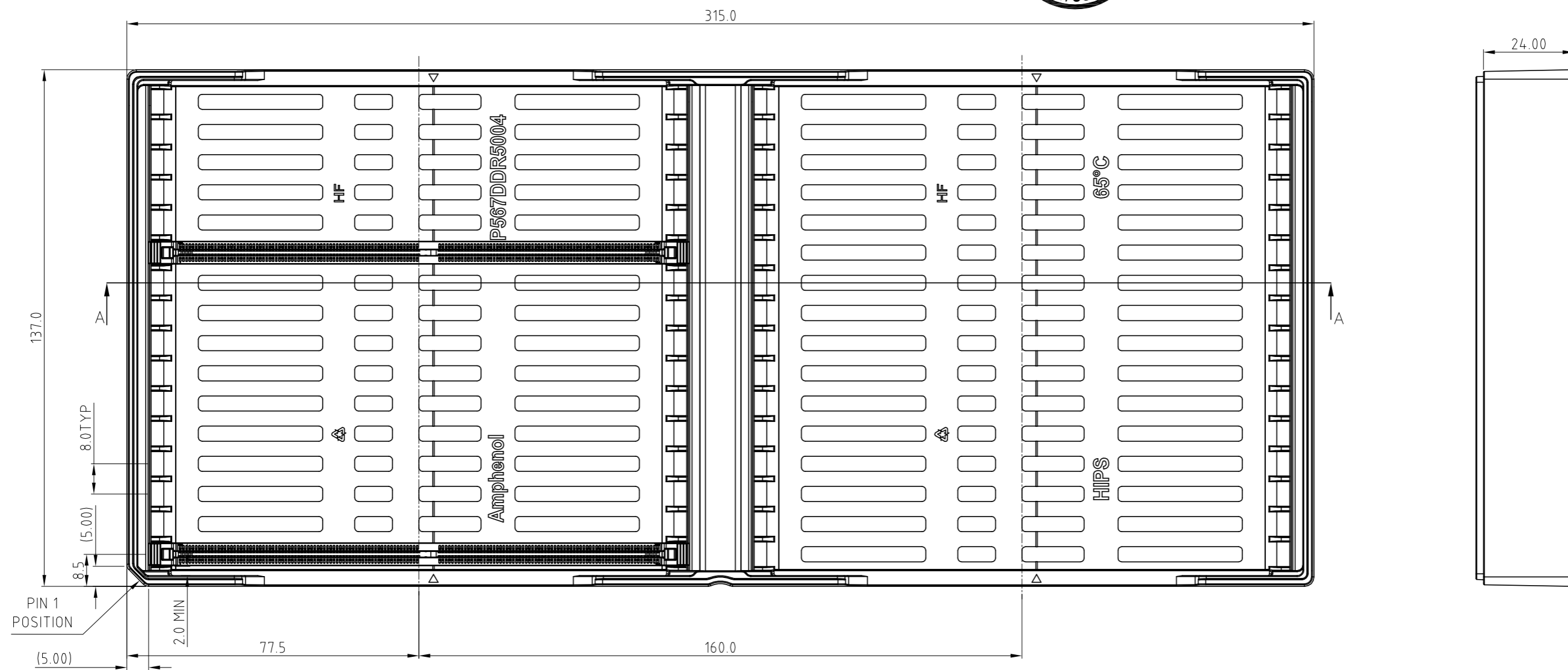

SECTION A-A

- NOTES:
 1. MATERIAL: HIPS, BLACK
 2. QUANTITY: 32PCS/TRAY

UNLESS OTHERWISE SPECIFIED TOLERANCES		APPROVAL	DATE	Amphenol	
.X	+/- 0.35	DRAWN	Kellen.Yang		
.XX	+/- 0.25	CHECKED			
.XXX	+/- 0.15	CHECKED			
FRACTIONS	+/-	DRAWING FILE : DRAWING\DDR\DDR504XXXXXXX			
ANGLES	+/- 3°	TITLE			
FOR MATERIALS AND FINISHES SEE NOTES		DDR5 288P R/LR DIMM CONNECTOR			
REMOVE SHARP EDGES		SIZE			
DIMENSIONS		DRAWING NO.			
U.S.	INCHES	A3 C DDR5-04-X-X-X-XXX-X-X			
(METRIC)	(MM)	SCALE	NONE	REV. 18	
		SHEET 5 OF 6			

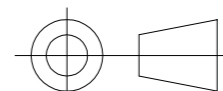

This document is the property of Amphenol Corporation and is delivered on the express condition that it is not to be disclosed, reproduced or used, in whole or in part, for manufacture or sale by anyone other than Amphenol Corporation without its prior consent, & that no right is granted to disclose or to use any information in this document.

CUSTOMER DRAWING

NOTES:

1. MATERIAL:
 - 1.1 HOUSING: HIGH TEMPERATURE THERMAL PLASTIC, UL94V-0, COLOR:OPTION.
 - 1.2 LATCH: HIGH TEMPERATURE THERMAL PLASTIC, UL94V-0. COLOR: OPTION.
 - 1.3 TERMINAL: COPPER ALLOY.
 - 1.4 BOARDLOCK: COPPER ALLOY.
 - 1.5 METAL CLIP: SUS.
2. FINISH:
 - 2.1 TERMINAL:
 - 2.1.1 CONTACT AREA: SELECTED GOLD PLATING;
 - 2.1.2 SOLDERING AREA: MATTE TIN PLATING 100u" THICKNESS MIN; UNDER PLATING: NICKEL PLATING 50u" THICKNESS MIN. UNLESS OTHERWISE SPECIFIED
 - 2.2 BOARDLOCK:
 - 2.2.1 100u" MIN LEAD FREE MATTE TIN OVER 50u" MIN NICKEL UNDERPLATED OVERALL.
3. ELECTRICAL CHARACTERISTICS:
 - 3.1 CONTACT CURRENT RATING:1.0A MAX
 - 3.2 INSULATION RESISTANCE:1MΩ MIN. 500V DC.
 - 3.3 DIELECTRIC WITHSTANDING VOLTAGE:500 VAC AT SEA LEVEL.
 - 3.4 LOW LEVEL CONTACT RESISTANCE:
 - INITIAL:40mΩ MAX.
 - FINAL:THE CHANGE IN LLCR BETWEEN THE READING AFTER STRESS AND THE INITIAL READING SHALL NOT EXCEED 20 mΩ MAX.
4. MECHANICAL CHARACTERISTICS:
 - 4.1 CONTACT RETENTION FORCE:300gF MIN/PER PIN.
 - 4.2 DURABILITY:25 CYCLES.
 - 4.3 INSERTION FORCE (MODULE TO CONNECTOR) :106.8N MAX. UNMATING FORCE :19.77N MIN.
5. RELIABILITY AND OTHER CHARACTERISTICS:
 - 5.1 SOLDERABILITY -LEAD FREE: JESD22-B102; CONDITION C, 8 HOURS ±15 MINUTES STEAM PRECONDITION.
 - 5.2 VIBRATION: EIA-364-28, RANDOM PROFILE:
 - 5 HZ @ 0.01 g²/HZ TO 20HZ @ 0.02g²/HZ (SLOPE UP), 20 HZ TO 500HZ @ 0.02g²/HZ (FLAT), INPUT ACCELERATION IS 3.13g RMS.
 - 5.3 CYCLIC TEMPERATURE AND HUMIDITY: PER EIA-364-31, METHOD III WITHOUT CONDITIONING, INITIAL MEASUREMENTS, COLD SHOCK AND VIBRATION.
 - 5.4 THERMAL SHOCK: PASSED PER EIA-364-32, METHOD A, TABLE 2, TEST CONDITION 1, -55°C TO 85°C. PERFORM 5 CYCLES IN MATED CONDITION.
 - 5.5 MECHANICAL SHOCK: EIA-364-27, TEST CONDITION E,
 - 5.6 OPERATING TEMPERATURE: -55°C TO 85°C.
6. HALOGEN-FREE COMPLIANT PRODUCT. MEET AMPHENOL SPEC # S-SN-004.
7. ORDER PN SYSTEM:



<p>DOUBLE DATA RATE 5 SERIES</p> <p>XX: APPLICATION TYPE 04: SMT,288P, R/LR DIMM CONNECTOR</p> <p>X: HOUSING COLOR 1: BLACK 2: NATURAL (IVORY) 3: YELLOW 4: BLUE</p> <p>X: LATCH COLOR 1: BLACK 2: NATURAL (IVORY) 3: YELLOW 4: BLUE</p> <p>X: CONTACT PLATED 0: GOLD FLASH 1: 15u" Au ON CONTACT AREA 2: 30u" Au ON CONTACT AREA 3: 15u" MIN GXT 4: 30u" MIN GXT 5: 15u" Au ON CONTACT AREA AND 90u" Ni MIN ON UNDERPLATING: 6: 30u" Au ON CONTACT AREA AND 90u" Ni MIN ON UNDERPLATING: 8: 18u" AU ON CONTACT AREA</p>	<p>DDR5 XX X X X XXX X X</p> <p>X: CUSTOMER CODE OPTION: BLANK 0..... 9 A..... Z</p> <p>X: PACKING AND MYLAR OPTIONS T: SOFT TRAY H: HARD TRAY PACKAGE, WITH MYLAR "X"=40MM J: HARD TRAY PACKAGE, WITH MYLAR "X"=70MM K: HARD TRAY PACKAGE, WITHOUT MYLAR M: HARD TRAY PACKAGE, WITH MYLAR "X"=90MM C: HARD TRAY PACKAGE, WITH CAP "X"=70MM;"Y"=6MM S: HARD TRAY PACKAGE, WITH MYLAR "X"=123.6MM</p>
--	--

SEE SEQUENCE NUMBER TABLE

REVISIONS				
SYM	ECN	DESCRIPTION	DATE	APPROVED
		SEE SHEET1		

SEQUENCE NUMBER		
CODE	OPTION DESCRIPTION	FIGURE DIM "H"
001	1. STANDARD HOUSING 2. STANDARD LATCH 3. FORK LOCK	(2.50)
002	1. STANDARD HOUSING 2. STANDARD LATCH 3. METAL TAB	(2.65)
005	1. STANDARD HOUSING 2. SHORT LATCH 3. FORK LOCK	(2.50)
006	1. STANDARD HOUSING 2. SHORT LATCH 3. METAL TAB	(2.65)
007	1. STANDARD HOUSING 2. STANDARD LATCH 3. METAL TAB	(1.85)
008	1. STANDARD HOUSING 2. SHORT LATCH 3. METAL TAB	(1.85)
009	1. STANDARD HOUSING 2. STANDARD LATCH 3. ONE FORK LOCK IN MIDDLE, TWO TABS ON BOTH SIDES	(2.50) (1.85)
.....		

UNLESS OTHERWISE SPECIFIED TOLERANCES U.S. METRIC .X +/- 0.35 .XX +/- 0.25 .XXX +/- 0.15 FRACTIONS +/- ANGLES +/- 3°	APPROVAL	DATE	<h1>Amphenol</h1>
	DRAWN Kellen.Yang	May.05.2022	
FOR MATERIALS AND FINISHES SEE NOTES	DRAWING FILE : DRAWING\DDR\DDR504XXXXXXX		TITLE DDR5 288P R/LR DIMM CONNECTOR
REMOVE SHARP EDGES	ANGLE OF PROJECTION		SIZE DRAWING NO. REV. A3 C DDR5-04-X-X-X-XXX-X-X 18
DIMENSIONS			SCALE NONE SHEET 6 OF 6
U.S. (METRIC)	INCHES (MM)		