

NOTES

1. MATERIAL
 HOUSING : LIQUID CRYSTAL POLYMER UL94V-0 (COLOR : BLACK)
 TERMINAL FOR POWER AND SIGNAL : COPPER ALLOY
2. PLATING
 - TERMINAL FOR POWER AND SIGNAL :
 CONTACT AREA : GOLD 0.1um MIN.
 TAIL AREA : GOLD 0.05um MIN.
 BASE PLATING : Ni 1.0um MIN.
 * DIVIDE INTO PARTS THE GOLD PLATING OF THE CONTACT AND THE TAIL PART BY THE NICKEL PLATING.
- FITTING NAIL :
 TAIL AREA : GOLD 0.05um MIN.
 BASE PLATING : Ni 1.0um MIN.
3. MATE WITH : 207420 SERIES.
4. TAIL COPLANARITY TO BE 0.08 MAX.

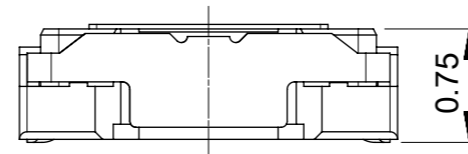
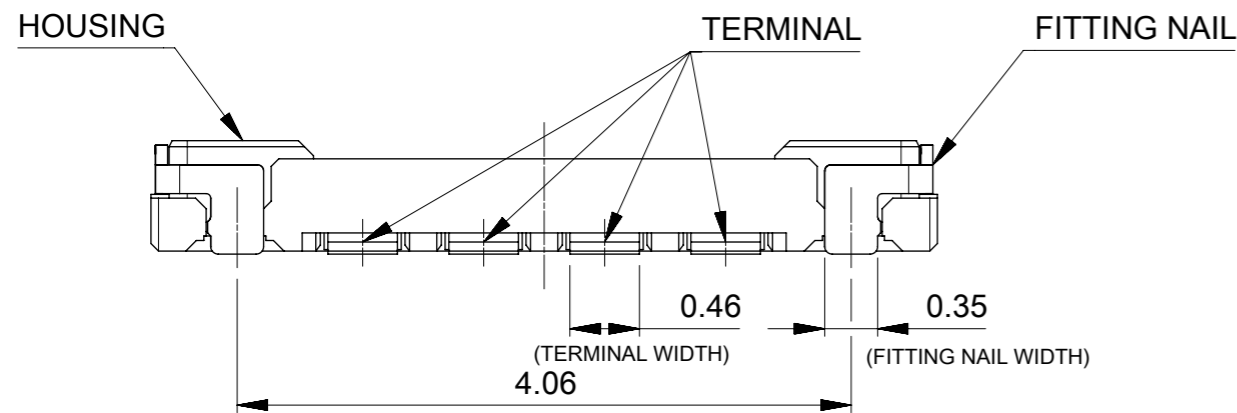
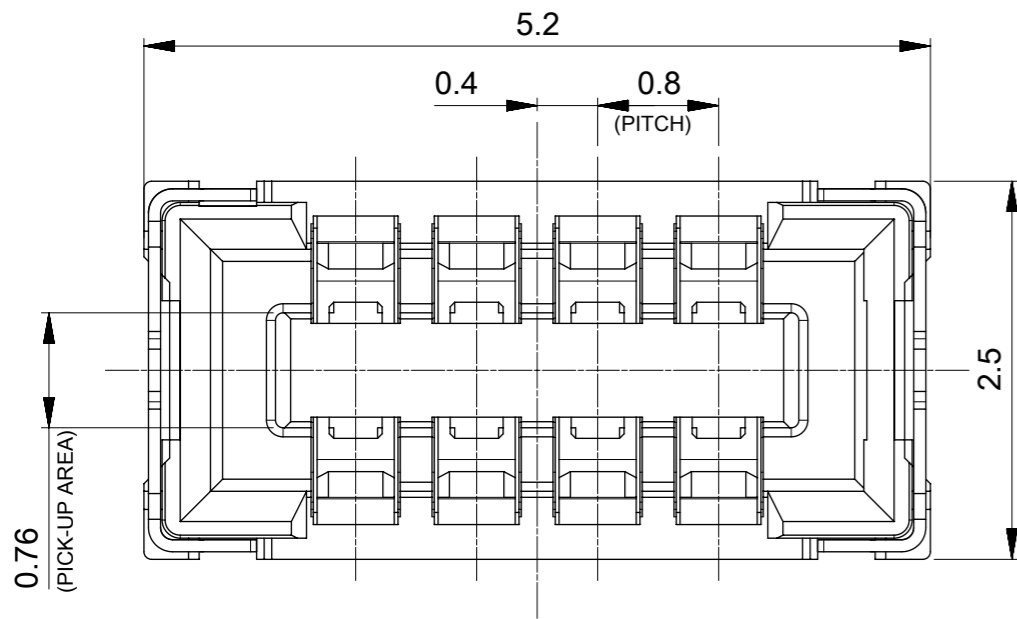
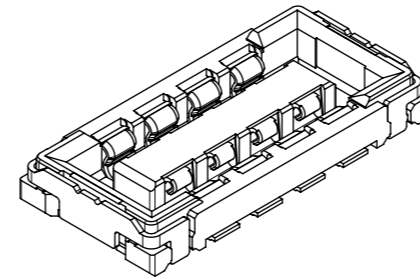

| | | | |
|-------------------------------|--------------------|---------------|----------|
| 207419-0081 | ○ | - | 8 |
| EMBOSSSED TAPE PACKAGE | MASS PRODUCTION | LOW VOL. TOOL | CIRCUITS |
| ORDER No. | SAMPLE PREPARATION | | |
| CONNECTOR SERIES No. : 207419 | | | |

| | | | | | | | |
|--|---|--|-------------------------|---|-------------------------------|--|--|
| SYMBOLS ▽ = 0 ▽ = 0 ▽ = 0 ▽ = 0 ▽ = 0 ▽ = 0 ▽ = 0 ▽ = 0 ▽ = 0 ▽ = 0 ▽ = 0 | THIS DRAWING CONTAINS INFORMATION THAT IS PROPRIETARY TO MOLEX ELECTRONIC TECHNOLOGIES, LLC AND SHOULD NOT BE USED WITHOUT WRITTEN PERMISSION | CURRENT REV DESC: RELEASED | | | | | |
| | DIMENSION UNITS: mm | SCALE: 20:1 | EC NO: 632527 | | | | |
| | GENERAL TOLERANCES (UNLESS SPECIFIED) | | DRWN: SYKO01 2020/02/18 | | 0.8MM BATTERY BTB 8P REC ASSY | | |
| | ANGULAR TOL ± 1.0° | | CHK'D: SHCHU 2020/02/18 | | | | |
| 4 PLACES ± | | APPR: YSKIM02 2020/02/20 | | PRODUCT CUSTOMER DRAWING | | | |
| 3 PLACES ± 0.1 | | INITIAL REVISION: | | | | | |
| 2 PLACES ± 0.15 | | DRWN: SYKO01 2018/03/16 | | DOCUMENT NUMBER: 2074190081 | | | |
| 1 PLACE ± 0.2 | | APPR: YSKIM02 2019/10/07 | | | | | DOC TYPE: PSD DOC PART: 000 REVISION: A2 |
| 0 PLACES ± | | DRAFT WHERE APPLICABLE MUST REMAIN WITHIN DIMENSIONS | | MATERIAL NUMBER: SEE TABLE CUSTOMER: GENERAL SHEET NUMBER: 1 OF 4 | | | |
| THIRD ANGLE PROJECTION | | DRAWING: A3-SIZE | | | | | SERIES: 207419 |
| DRAWING: A3-SIZE | | SERIES: 207419 | | | | | |

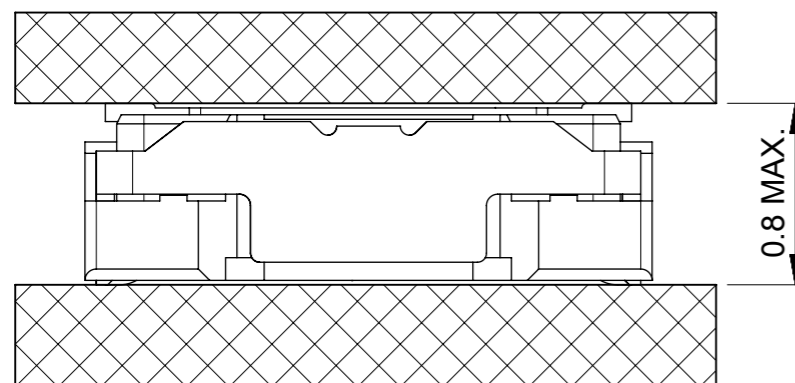

MATED CONDITION
SCALE 30:1

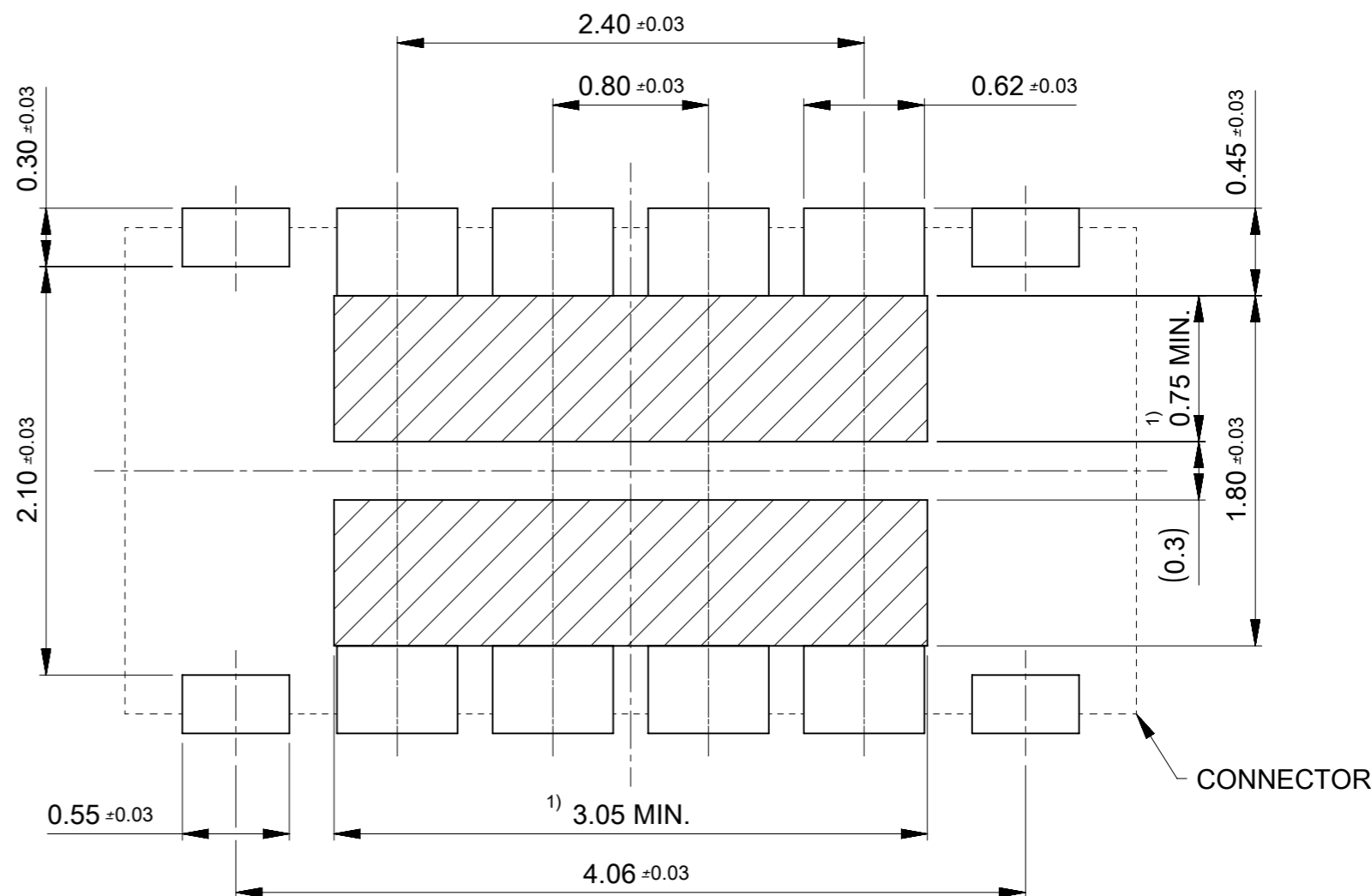

RECOMMENDED P.W.BOARD PATTERN LAYOUT(FOR REFERENCE)
 RECOMMENDED THICKNESS OF METAL MASK : t=0.1mm
 RECOMMENDED OPEN APERTURE RATIO OF METAL MASK : 80%

1)
 PROHIBITED AREA OF PATTERN WIRING AND SOLDER.
 (FOR EACH AREA THE WIRING CAN NOT BE AVAILABLE
 AND COVERED WITH A FILM KEEP SOLDER OUT)

| | | | | | |
|--|--|--|--|--|--|
| SYMBOLS ▽ = 0 ▽ = 0 ▽ = 0 ▽ = 0 ▽ = 0 ▽ = 0 ▽ = 0 ▽ = 0 ▽ = 0 ▽ = 0 ▽ = 0 ▽ = 0 | THIS DRAWING CONTAINS INFORMATION THAT IS PROPRIETARY TO MOLEX ELECTRONIC TECHNOLOGIES, LLC AND SHOULD NOT BE USED WITHOUT WRITTEN PERMISSION DIMENSION UNITS SCALE mm 20:1 | | CURRENT REV DESC: RELEASED | | |
| | GENERAL TOLERANCES (UNLESS SPECIFIED) ANGULAR TOL ± 1.0° | | EC NO: 632527 DRWN: SYKO01 2020/02/18 CHK'D: SHCHU 2020/02/18 APPR: YSKIM02 2020/02/20 | | |
| 4 PLACES ± 3 PLACES ± 0.1 2 PLACES ± 0.15 1 PLACE ± 0.2 0 PLACES ± | | INITIAL REVISION: DRWN: SYKO01 2018/03/16 APPR: YSKIM02 2019/10/07 | | PRODUCT CUSTOMER DRAWING | |
| DRAFT WHERE APPLICABLE MUST REMAIN WITHIN DIMENSIONS | | THIRD ANGLE PROJECTION | | DOCUMENT NUMBER DOC TYPE DOC PART REVISION 2074190081 PSD 000 A2 | |
| DRAWING SERIES MATERIAL NUMBER CUSTOMER SHEET NUMBER A3-SIZE 207419 SEE SHEET 1 GENERAL 2 OF 4 | | | | | |

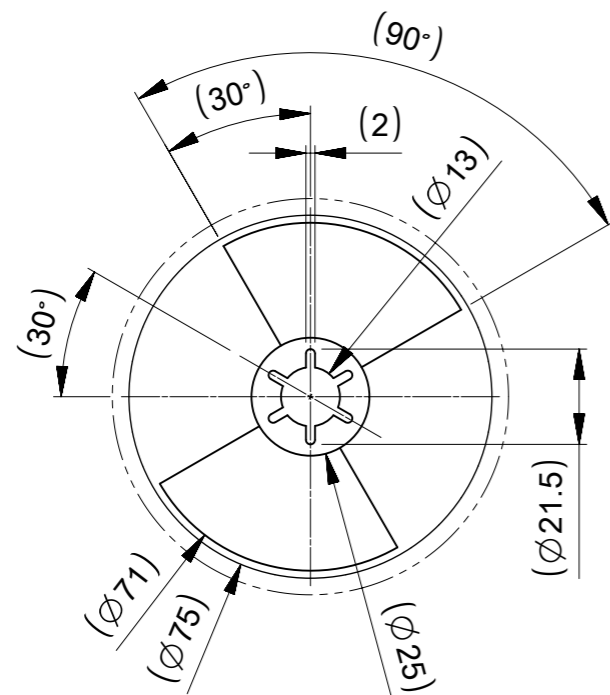
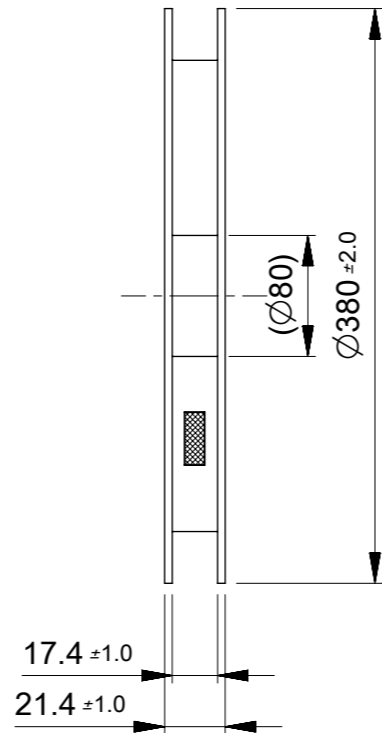
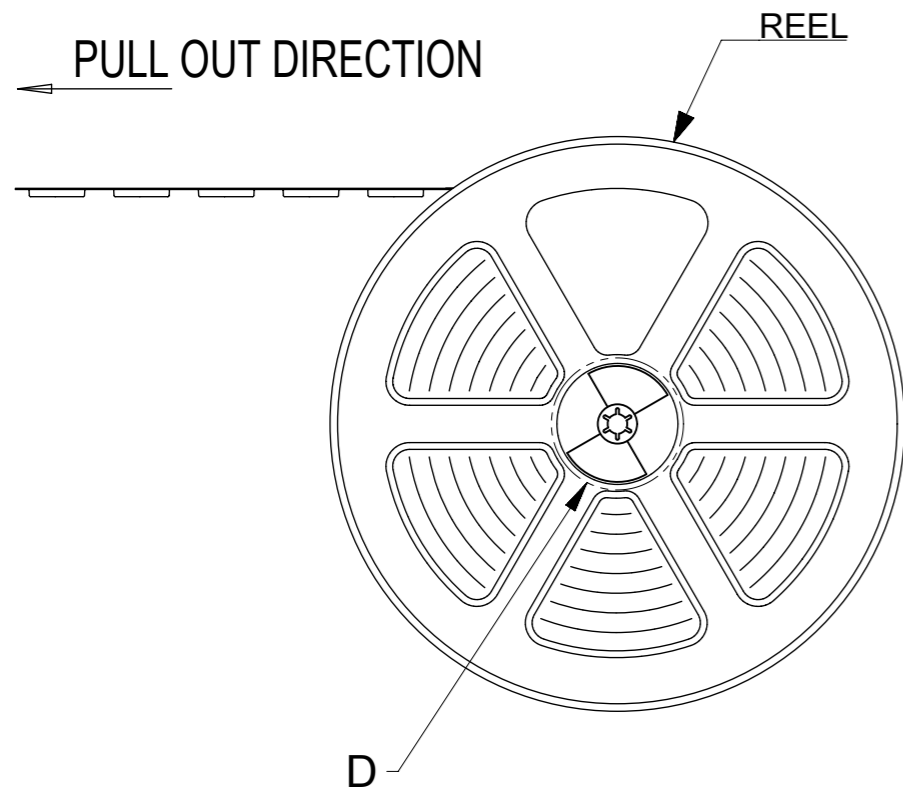

DETAIL D
SCALE 2:1

NOTES

1. NUMBER OF CONNECTORS : 7,000PCS/REEL
2. LEAD TAPE LENGTH :

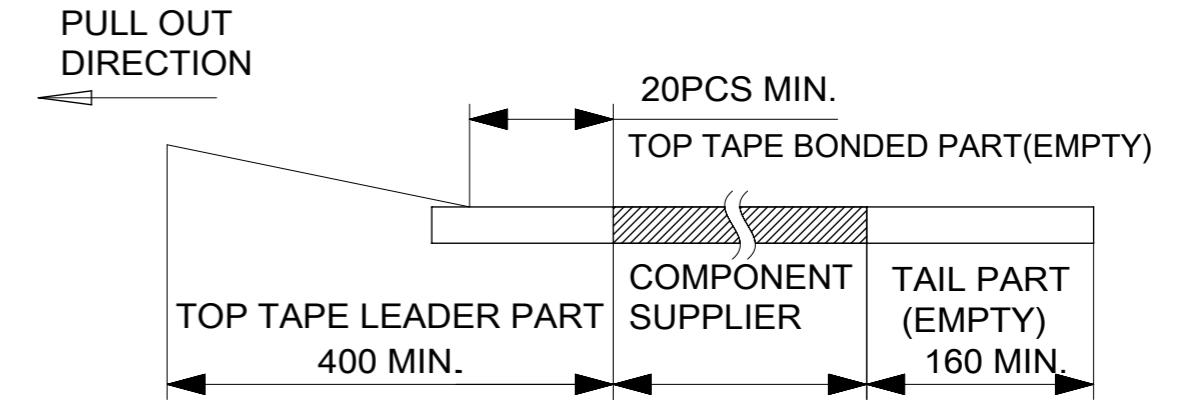

3. PEEL OFF FORCE OF THE TOP TAPE IS DEFINED BY IEC 60286-3 OR JES-59.
- PEELING DIRECTION AS SHOWN IN FOLLOWING FIG.
(PEEL OFF FORCE OF TOP TAPE : 0.6±0.35N(60±35gf))
(PEEL OFF SPEED : 300mm/Min.(REF))

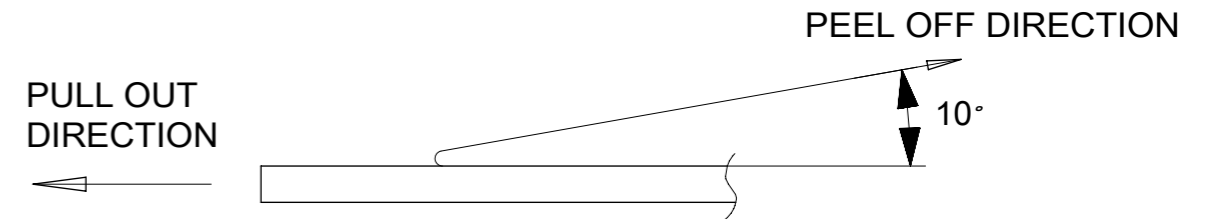

4. TOP TAPE POSITION
NO MORE THAN 1/3 OF PILOT HOLE DIAMETER IS COVERED WITH TOP TAPE.
5. MATERIAL
CARRIER TAPE : POLYSTYRENE
TOP TAPE : PET, OTHER
REEL : PS
POLYSTYRENE(PS) (RECYCLE MATERIAL CONTAINED)
6. MUST MEET THE CHAMICAL SUBSTANCE GUIDELINE TO CONTROL ENVIRONMENTAL HAZARDOUS SUBSTANCES.
7. REFER TO PS-2074190000 FOR CONDITIONS AFTER OPEN.

| | | | | | |
|---------|---|------------------------|----------------------------|--------------|-------------------------------|
| SYMBOLS | THIS DRAWING CONTAINS INFORMATION THAT IS PROPRIETARY TO MOLEX ELECTRONIC TECHNOLOGIES, LLC AND SHOULD NOT BE USED WITHOUT WRITTEN PERMISSION | | CURRENT REV DESC: RELEASED | | molex |
| | DIMENSION UNITS | SCALE | | | |
| ▽ = 0 | mm | 1:1 | | | 0.8MM BATTERY BTB 8P REC ASSY |
| ▽ = 0 | GENERAL TOLERANCES (UNLESS SPECIFIED) | | | | PRODUCT CUSTOMER DRAWING |
| ▽ = 0 | ANGULAR TOL ± 1.0° | | | | |
| ▽ = 0 | 4 PLACES | ± | EC NO: 632527 | 2020/02/18 | DOCUMENT NUMBER |
| ▽ = 0 | 3 PLACES | ± 0.1 | DRWN: SYKO01 | 2020/02/18 | |
| ▽ = 0 | 2 PLACES | ± 0.15 | CHK'D: SHCHU | 2020/02/18 | DOC TYPE |
| ▽ = 0 | 1 PLACE | ± 0.2 | APPR: YSKIM02 | 2020/02/20 | DOC PART |
| ▽ = 0 | 0 PLACES | ± | INITIAL REVISION: | | REVISION |
| □ = 0 | DRAFT WHERE APPLICABLE MUST REMAIN WITHIN DIMENSIONS | | DRWN: SYKO01 | 2018/03/16 | A2 |
| ▽ = 0 | | | APPR: YSKIM02 | 2019/10/07 | |
| | | THIRD ANGLE PROJECTION | DRAWING | SERIES | MATERIAL NUMBER |
| | | | A3-SIZE | 207419 | SEE SHEET 1 |
| | | | CUSTOMER | SHEET NUMBER | |
| | | | GENERAL | 3 OF 4 | |

PULL OUT DIRECTION →

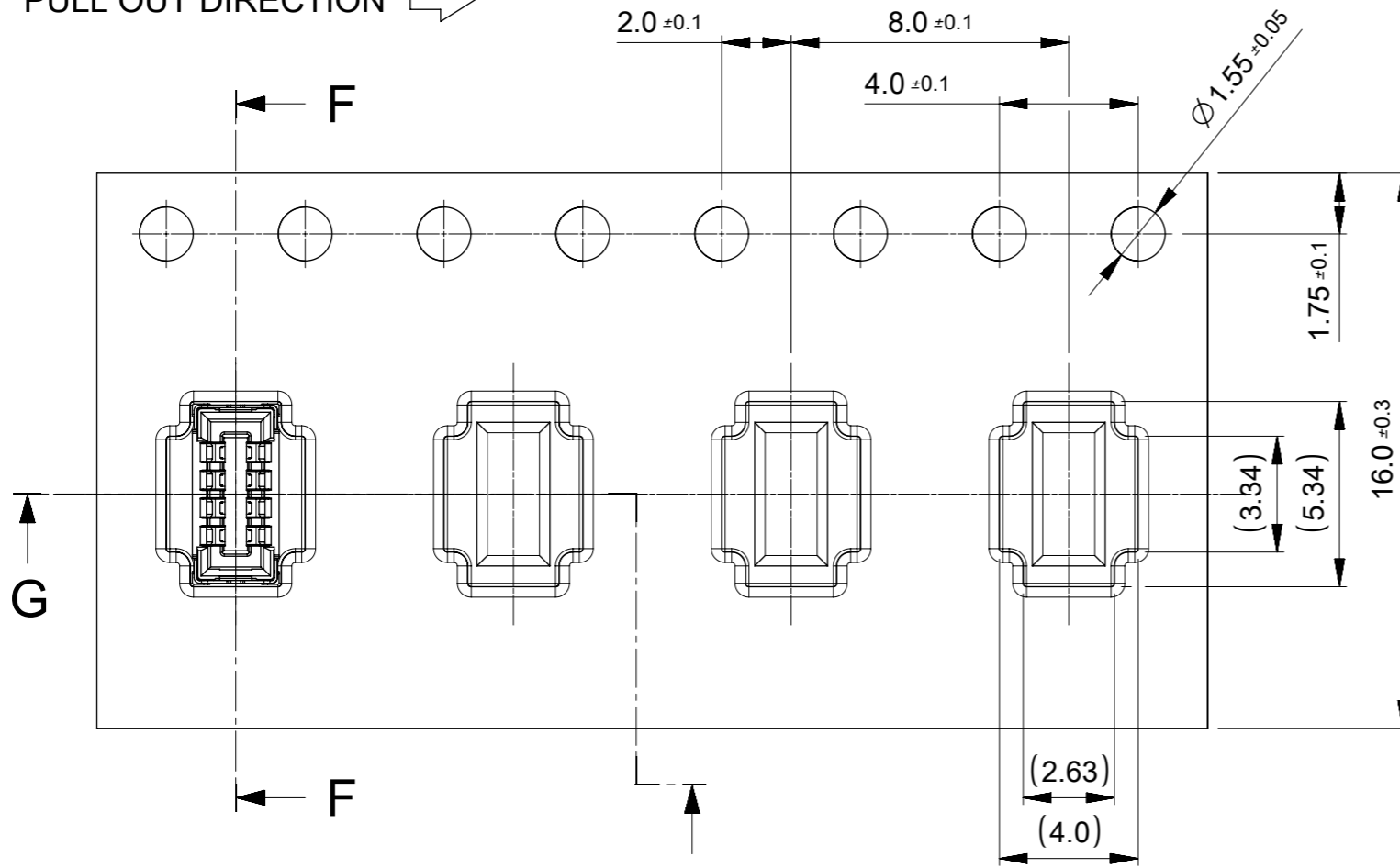

SCALE 5:1

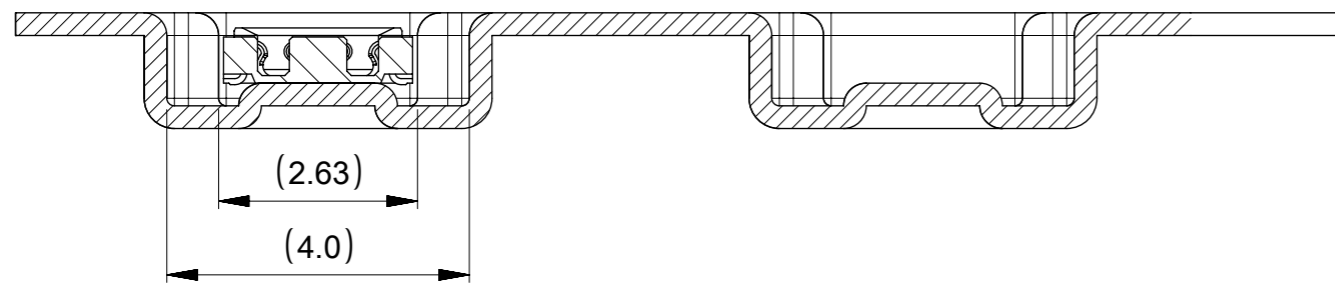

SECTION G-G
SCALE 10:1

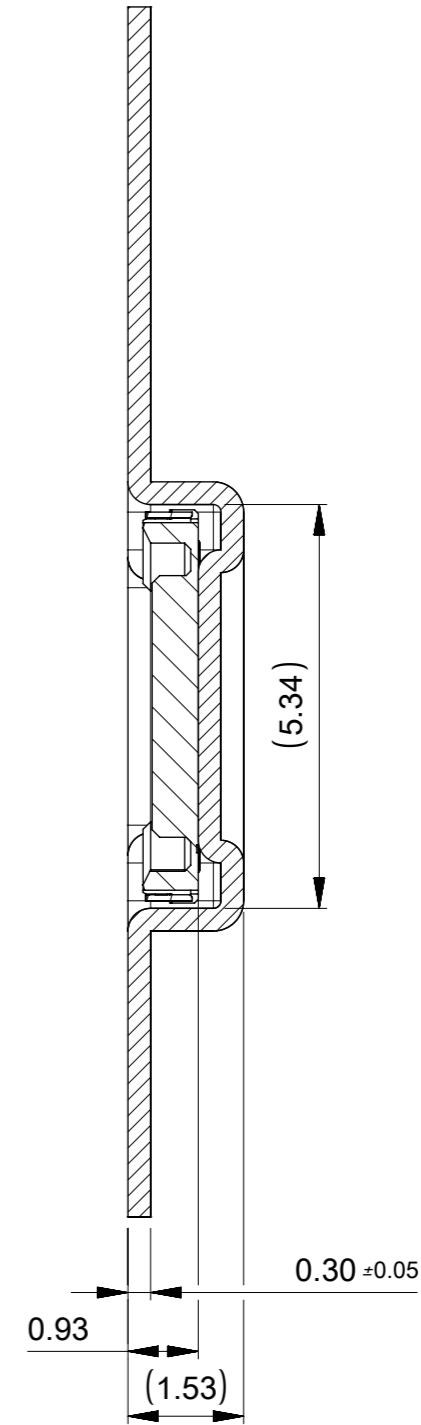

SECTION F-F
SCALE 10:1

| | | | | | |
|---------|--|---|--|--------|-----------------|
| SYMBOLS | | THIS DRAWING CONTAINS INFORMATION THAT IS PROPRIETARY TO MOLEX ELECTRONIC TECHNOLOGIES, LLC AND SHOULD NOT BE USED WITHOUT WRITTEN PERMISSION | | | |
| ▽ = 0 | mm | SCALE | CURRENT REV DESC: RELEASED | | |
| ▽ = 0 | GENERAL TOLERANCES (UNLESS SPECIFIED) | 5:1 | <p>molex</p> <p>0.8MM BATTERY BTB 8P REC ASSY</p> <p>PRODUCT CUSTOMER DRAWING</p> | | |
| ▽ = 0 | ANGULAR TOL | ± 1.0° | | | |
| ▽ = 0 | 4 PLACES | ± | | | |
| ▽ = 0 | 3 PLACES | ± 0.1 | | | |
| ▽ = 0 | 2 PLACES | ± 0.15 | | | |
| ▽ = 0 | 1 PLACE | ± 0.2 | | | |
| □ = 0 | 0 PLACES | ± | <p>EC NO: 632527</p> <p>DRWN: SYKO01 2020/02/18</p> <p>CHK'D: SHCHU 2020/02/18</p> <p>APPR: YSKIM02 2020/02/20</p> | | |
| ■ = 0 | DRAFT WHERE APPLICABLE MUST REMAIN WITHIN DIMENSIONS | THIRD ANGLE PROJECTION | DRAWING | SERIES | MATERIAL NUMBER |
| ▽ = 0 | | | A3-SIZE | 207419 | SEE SHEET 1 |
| | | | | | CUSTOMER |
| | | | | | GENERAL |
| | | | | | SHEET NUMBER |
| | | | | | 4 OF 4 |
| | | | | | DOCUMENT NUMBER |
| | | | | | 2074190081 |
| | | | | | DOC TYPE |
| | | | | | PSD |
| | | | | | DOC PART |
| | | | | | 000 |
| | | | | | REVISION |
| | | | | | A2 |