

CAT 6 Data Wiring System Connectors

TM23 Series



■ Features

1. High-Speed Data Transfer

Conforms to the TIA/EIA-568B.2-1 data Wiring standard, thereby clears CAT 6 transfer performance requirements. As such, these products easily support Gigabit Ethernet (1000BASE-T/1000BASE-TX), which is the next generation of high-speed applications.

2. A Product Lineup Focused on Building of a Complete System

In addition to modular plugs, Hirose Electric offers box type outlets, patch panels, and wall outlets. Systems built using all components from the same manufacturer will assure stable data transfer.

3. Support of a Wide Variety of Manufacturers' CAT 6 Cable

To assure high performance of the system we test and monitor data transfer using CAT 6 cables manufactured by different suppliers.

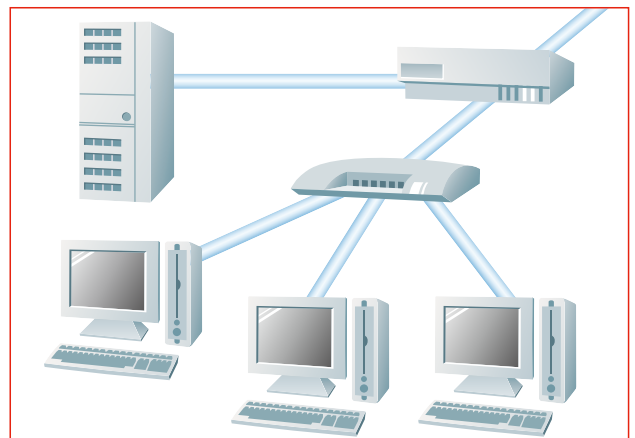
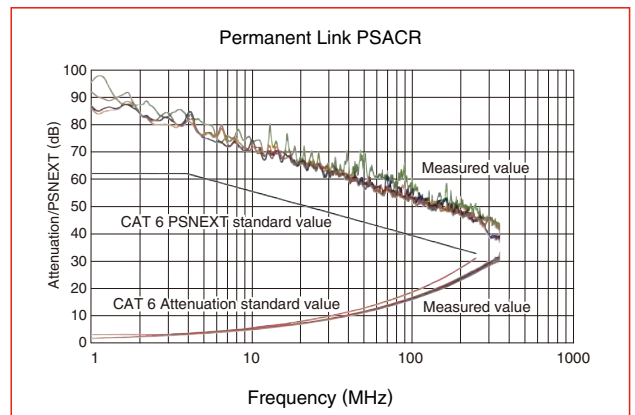

■ Plugs, Boots

■ Specifications

Rating	Current rating	1A	Operating temperature range -25°C to +60°C (Note)
	Voltage rating	125V AC	

Item	Specification	Conditions
1. Insulation resistance	100 M ohms min.	100 V DC
2. Withstanding voltage (between adjacent contacts)	No flashover or insulation breakdown.	500 V AC / one minute
3. Contact resistance	230 m ohms max.	100mA
4. Vibration	No electrical discontinuity of 5μs min. Contact resistance : 250m ohms max.	Frequency: 10 to 55 Hz, single amplitude of 0.75 mm, 1 octave/min. conduct, 10 cycles to each 3 directions.
5. Shock	No electrical discontinuity of 5μs. min. Contact resistance : 250m ohms max.	Acceleration of 490 m/s ² , 11 ms duration, sine half-wave waveform, 3 cycles in each of the 6 axes.
6. Durability (mating/un-mating)	Contact resistance : 250m ohms max.	200 cycles
7. Temperature cycle	Contact resistance : 250 m ohms max. Insulation resistance : 100 M ohms min.	Temperature : -55±3°C → +15°C to +35°C → +85±2°C → +15°C to +35°C Duration (Minutes): 30 ⁺⁵ ₀ → 2 to 3 → 30 ⁺⁵ ₀ → 2 to 3 5 cycles
8. Humidity	Contact resistance: 250 m ohms max. Insulation resistance: 1 M ohms min. (High humidity) Insulation resistance: 100 M ohms min. (Dry state)	500 hours at temperature of 40°C and humidity of 90% to 95%.
9. Salt Spray	Contact resistance: 250 m ohms max.	5% salt water/48 hours.

Note: Includes temperature rise caused by current flow.

■ Materials and Finishes

Plugs

Component	Material	Finish	Remarks
Insulator	Polycarbonate	Color: Clear	UL94V-0
Contacts	Phosphor bronze	Contact area: Gold plated	—————
Strain relief clamp	Brass	Nickel plated	—————

Boots

Component	Material	Finish	Remarks
Insulator	EPTR	White (Standard color)	UL94V-0
		Black, red, blue, yellow, green, orange, gray, light blue	—————

■ Ordering Information

● Plugs

TM23 - P - 8 8P
① ② ③ ④

① Series name	: TM23
② Connector type	P : Plug
③ Size	8 : 8 contacts
④ Inserted contacts	8P : 8 contacts

● Boots

TM23 - P - 8 BT
① ② ③ ④

① Series name	: TM23
② Connector type	P : Plug
③ Size	8 : 8 contacts
④ BT	: Boot

● Jacks

TM23 R - 5A 8 8
① ② ③ ④ ⑤

① Series name	: TM23
② Connector type	R : Jack
③ Mounting style/termination type	5A : Right-angle/through hole
④ Jack opening code	8 : For 8 contacts
⑤ Number of inserted contacts	8 : 8 contacts

Plugs

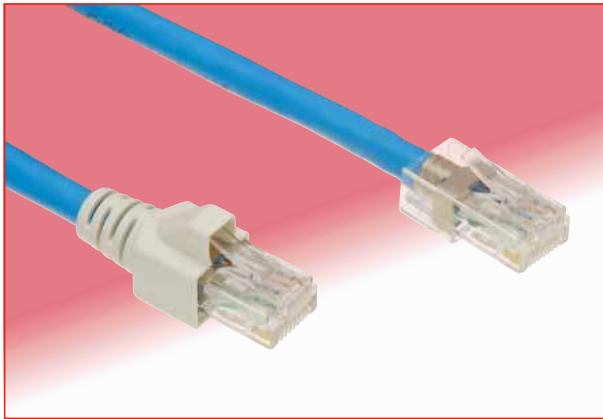

Overview

- Contact configured for CAT 6 performance.
- 0.5 mm dia. solid wire or AWG #24 stranded wire.
- Use with cables having external diameters of 5.4 mm to 6.8mm.
- Strain relief clamp protects the contact/conductor termination areas.

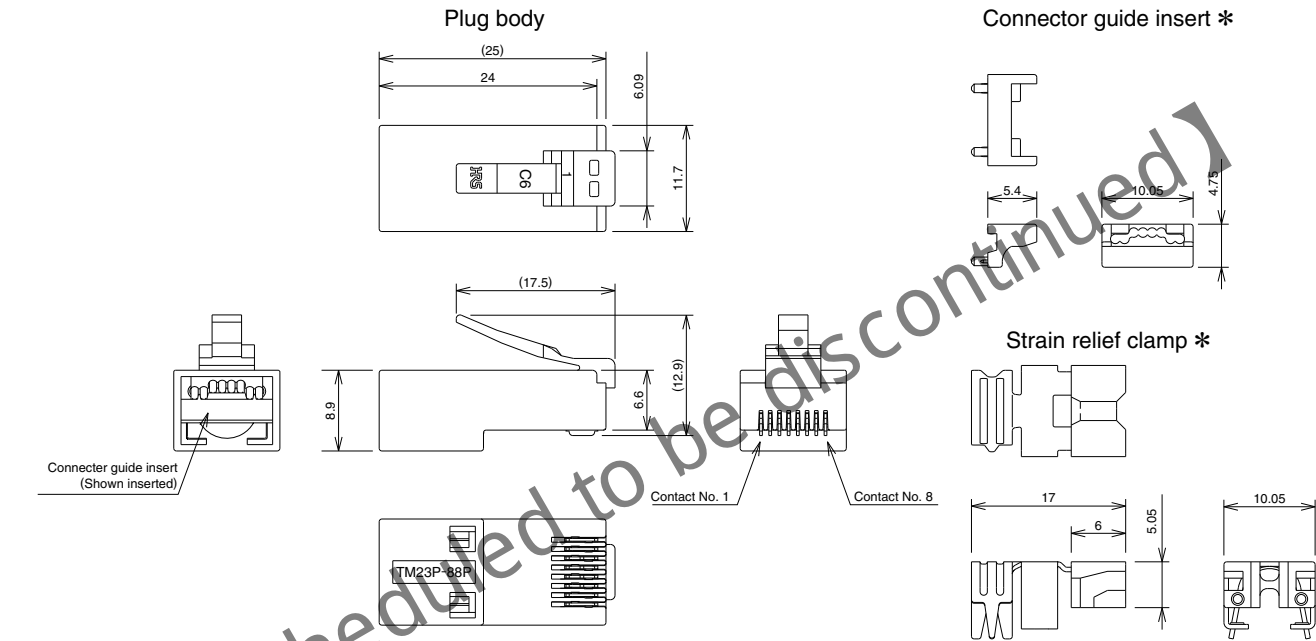

Part No.	CL No.	RoHS
TM23P-88P	222-2916-6	YES

Mated with corresponding receptacle (Shown for reference only)

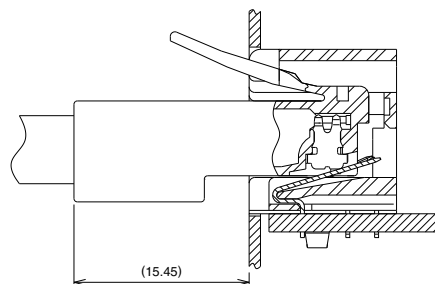

* Supplied separately(1bag contains 1pcs.)

Boots

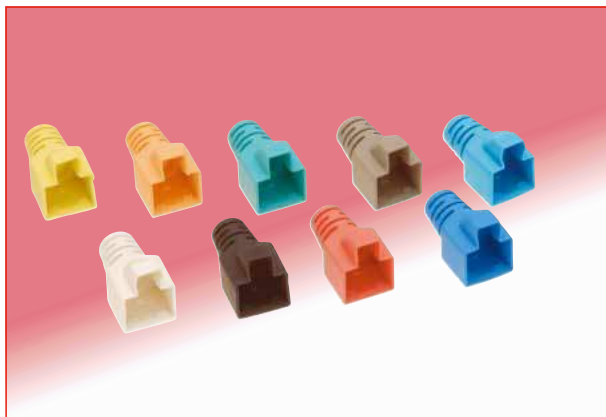

Overview

- Dedicated boots for the TM23P-88P.
- 9 color variations.
- Halogen-free.
- Protects the plug's lock/release lever.

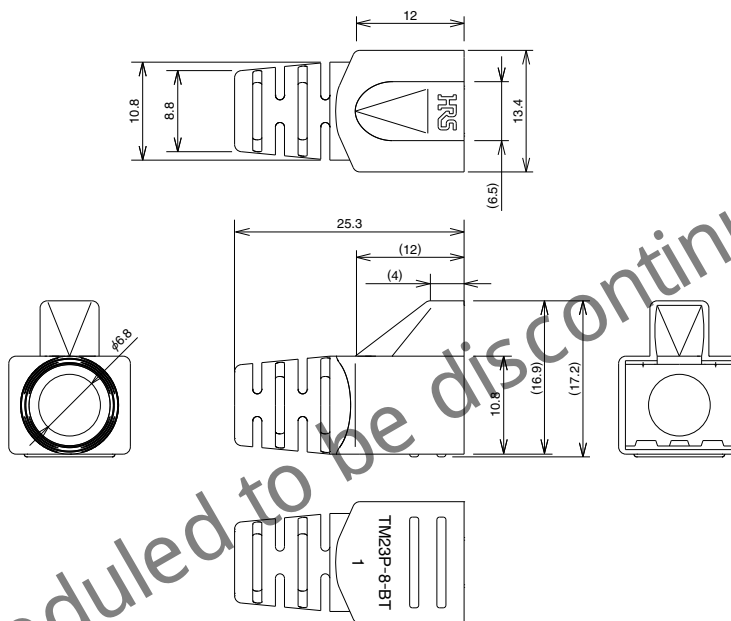

Part Number	CL No.	Color	RoHS
TM23P-8-BT	222-2917-9	White	YES
TM23P-8-BT(01)	222-2917-9-01	Black	
TM23P-8-BT(02)	222-2917-9-02	Red	
TM23P-8-BT(03)	222-2917-9-03	Blue	
TM23P-8-BT(04)	222-2917-9-04	Yellow	
TM23P-8-BT(05)	222-2917-9-05	Green	
TM23P-8-BT(06)	222-2917-9-06	Orange	
TM23P-8-BT(07)	222-2917-9-07	Gray	
TM23P-8-BT(08)	222-2917-9-08	Light Blue	

Boot installed

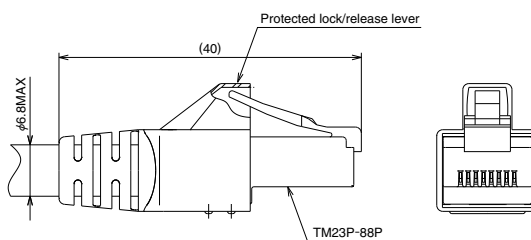

Manual Termination Tool

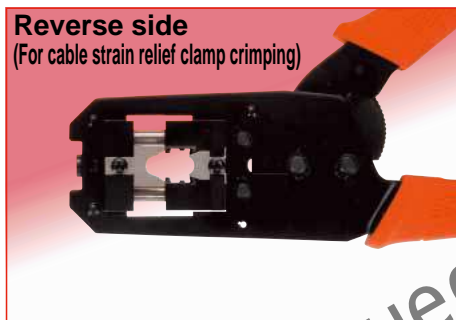

Part No.	CL No.
HT601-TM23/22P-88P	902-2128-1

* Changing the "A" Assembly parts to TM22 dedicated clamp parts will allow wiring of Hirose's TM22P-88P plugs supporting CAT 5e.

Automatic Contact Termination Machine

Item	Part Number	CL No.
Body	CM-105	CL901-0005-4
Applicator	AP105-TM23P-88P	CL901-2588-5

Cable Strain Relief Clamp Crimping Jig (Manual operated)

Part Number	CL No.
TM23P-88P/CK-MP(01)	CL902-2130-3(01)

Recommended Cable Specification

	Conductor	Solid copper conductor: 0.5mm dia. Stranded copper conductor: AWG#24
	Individual conductor insulation dia.	(0.95mm to 1.05mm)
	Overall jacket dia.	(5.4mm to 6.8mm)

Note: To achieve CAT 6 performance, refer to TM23P-88P Cable Termination Procedure Manual(ETAD-E2415).

■ Jacks

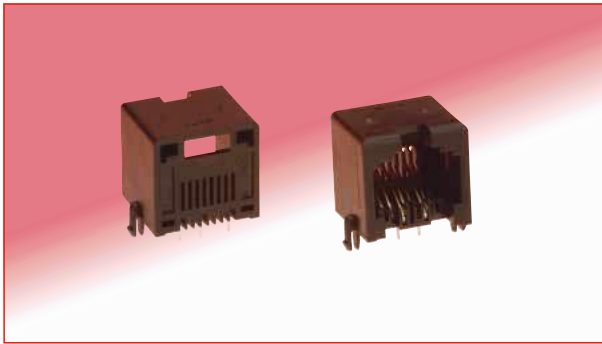

◆ Overview

- Unique contact structure designed for crosstalk reduction. (Through hole : 3 rows)
- Temporary retention to board with integral flexible posts.

◆ PCB mounting pattern

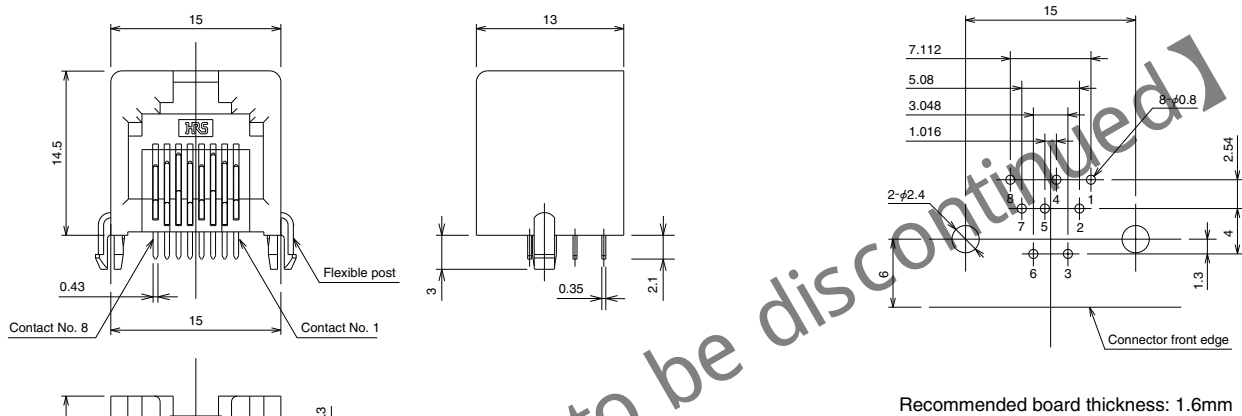

Part Number	CL No.	Color	RoHS
TM23R-5A-88(50)	222-2918-1-50	Black	YES

Note: The jack by itself does not clear CAT 6 performance requirements. Compensation on the board is required to secure CAT 6 performance.

■ Precautions in System Construction

The TM23 Series connector and components were designed for CAT 6 data transfer. However, it is highly recommended that the entire connected system be checked for this performance level.

● Cable termination procedures

Cable termination procedure manual No.	Part Number
ETAD-E2415	TM23P-88P

● Recommended Cable Manufacturers

Hirose Electric closely examines the transfer performance of these connectors with the CAT 6 cable that is manufactured and sold by the various cable manufacturers. Please use the cable from among those indicated in Table 1 for system construction with the TM23 Series.

Table1 Recommended Cable Manufacturers

Manufacturer's Name	Web Site
Hitachi Cable, Ltd.	http://www.hitachi-cable.co.jp/index-e.html
Tonichi Kyosan Cable, Ltd.	http://www.tonichi-kyosan.co.jp/
NipponSeisen Co. Ltd.	http://www.nscable.co.jp/
Okano Electric Wire Co., Ltd.	http://www.okano-cable.co.jp/english/index.html
Tsushin Kogyo K.K.	http://www.tsuko.co.jp/
Showa Electric Wire & Cable Co., Ltd.	http://www.swcc.co.jp/eng/index.html
Fuji Electric Cable Co, Ltd.	http://www.tokyo-fuji.co.jp/index-f.htm

Note: Please see the web sites of the various manufacturers for cable specifications.
Contact HRS for recommendations when using cables from other suppliers.

● Use of Different Manufacturers' Components

Use of different manufacturers' components in one system could cause the deterioration of transfer performance.

● Check of the System Performance Verification

All measures have been taken to assure the transfer performance of the TM23 series. However, it is highly recommended to verify transfer performance of complete system using commercially available measuring instruments.

Hirose Electric does not build wiring systems. Please contact Hirose Electric sales representative for system construction contractor information.

Technical Documentation

CAT 6 Transmission Characteristics Data

This is representative transfer performance for the TM23 Series. A high margin is used for CAT 6 standard values.

Permanent Links

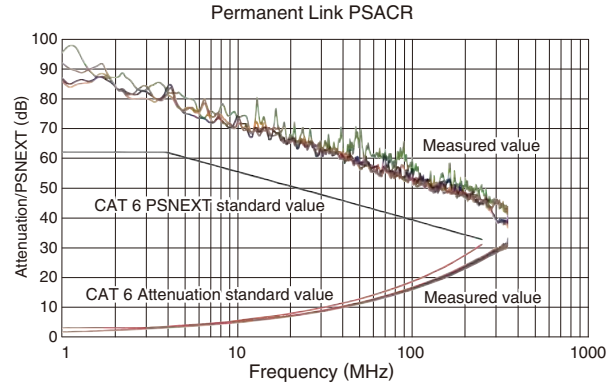
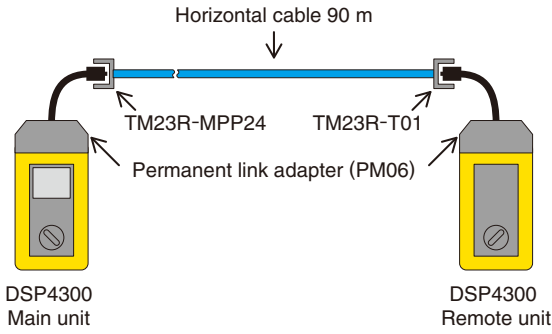

Channel Links

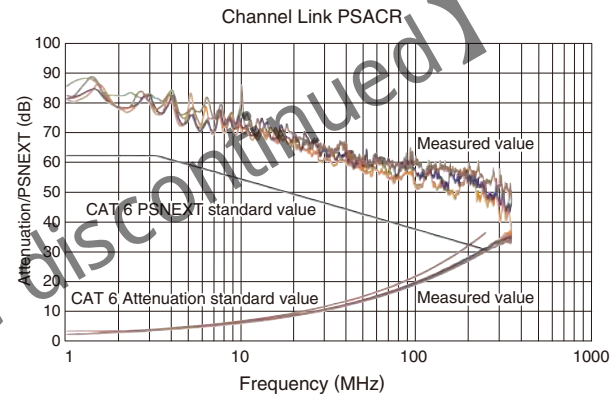
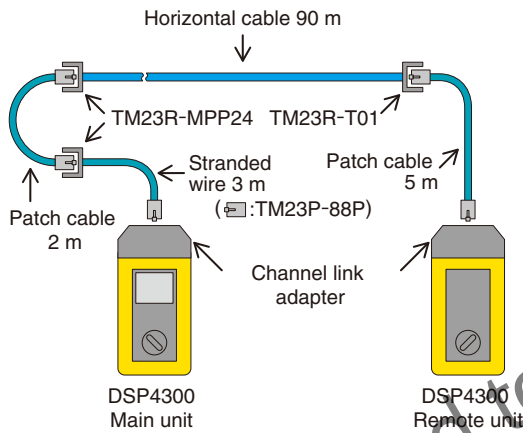

Patch Cable

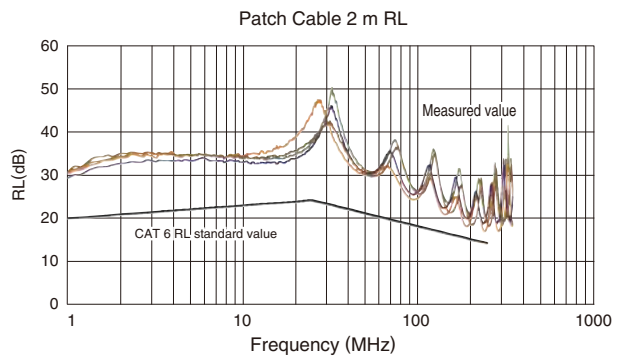
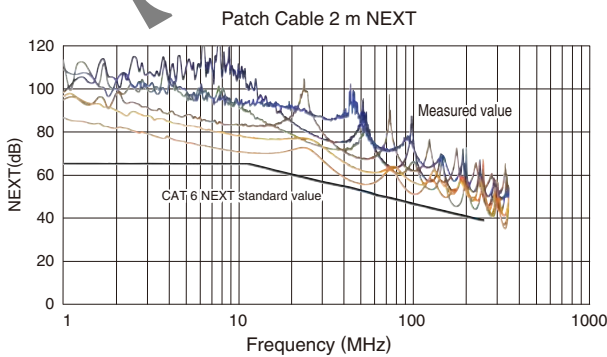
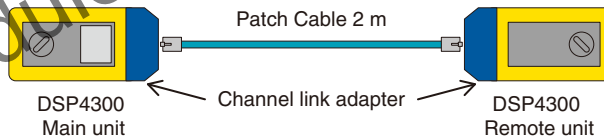

HIROSE ELECTRIC CO.,LTD.

5-23,OSAKI 5-CHOME,SHINAGAWA-KU,TOKYO 141-8587,JAPAN

PHONE: 81-3-3491-9741, FAX: 81-3-3493-2933

<http://www.hirose.com>

<http://www.hirose-connectors.com>