

## Features

- Operates as a 4-bit GTL-/GTL/GTL+ to GTL-/GTL/GTL+ bus buffer
- 2.3 V to 3.6 V operation
- GTL input and output 3.6 V tolerant
- Vref adjustable from 0.5 V to VCC/2
- Partial power-down permitted
- ESD protection exceeds 2000 V HBM per JESD22-A114 and 1000 V CDM per JESD22-CC101
- Latch-up protection exceeds 200 mA per JESD78
- Package offered: TSSOP14

## Description

The GTL2034 is a 4-bit GTL-/GTL/GTL+ bus buffer. The GTL2034 GTL inputs and outputs operate up to 3.6 V, allowing the device to be used in higher voltage open-drain output applications.

## Pin Configuration

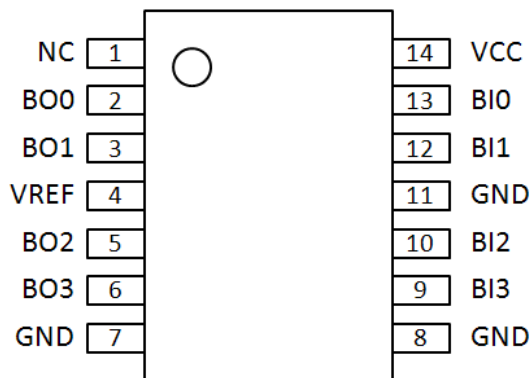

## Pin Description

NC	1	not connected
BO0	2	data outputs (GTL)
BO1	3	
BO2	5	
BO3	6	
BI0	13	data inputs (GTL)
BI1	12	
BI2	10	
BI3	9	
VREF	4	GTL reference voltage
GND	7,8,11	ground (0 V)
VCC	14	positive supply voltage

**Block Diagram**

Figure 1: Block diagram

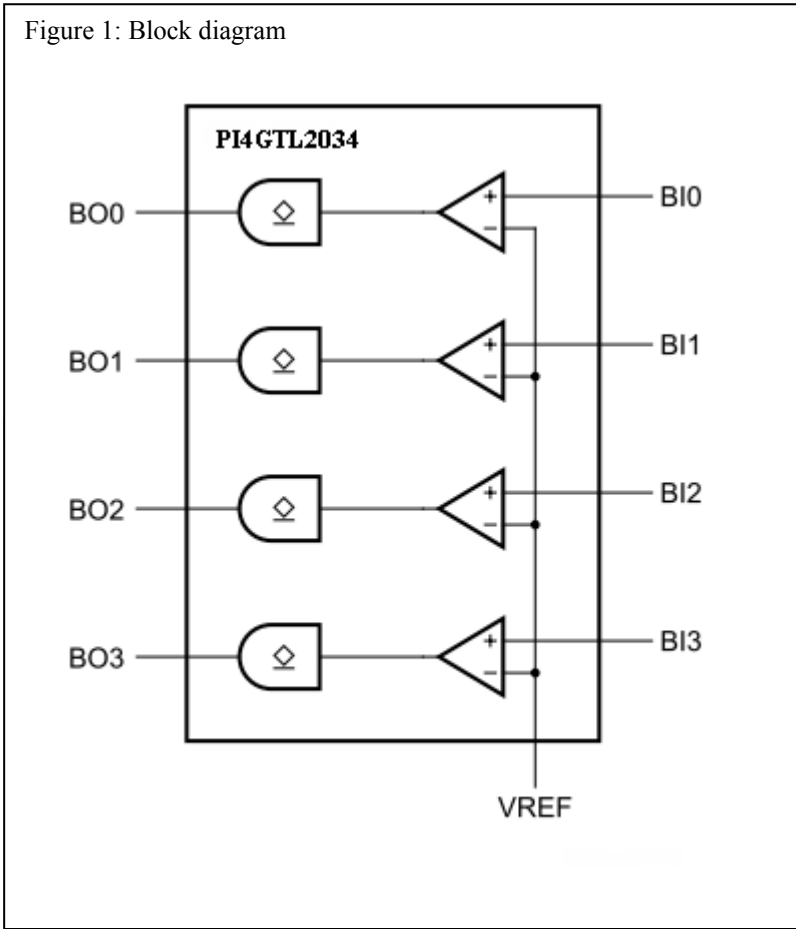

**Function Table:**

BIx	BOx
Input	Output

## Maximum Ratings

Power supply.....	-0.5V to +4.6V
Voltage on an I/O pin.....	GND-0.5V to +4.6V
Supply current.....	±160mA
Ground supply current.....	400mA
Total power dissipation.....	200mW
Operation temperature.....	-40~85°C
Storage temperature.....	-65~150°C
Maximum Junction temperature, T <sub>j(max)</sub> .....	125°C
Total power dissipation.....	200mW

### Note:

Stresses greater than those listed under MAXIMUM RATINGS may cause permanent damage to the device. This is a stress rating only and functional operation of the device at these or any other conditions above those indicated in the operational sections of this specification is not implied. Exposure to absolute maximum rating conditions for extended periods may affect reliability.

## Limiting Values

Symbol	Parameter	Conditions	Min.	Max.	Unit
VCC	Supply voltage		-0.5	4.6	V
I <sub>IK</sub>	Input clamping current	V <sub>I</sub> < 0V	-	-50	mA
V <sub>I</sub>	Input voltage	B port	-0.5 <sup>[1]</sup>	4.6	V
I <sub>OK</sub>	Output clamping current	V <sub>O</sub> < 0V	-	-50	mA
V <sub>O</sub>	Output voltage	output in OFF or HIGH state B port	-0.5 <sup>[1]</sup>	4.6	V
I <sub>OL</sub>	LOW-level output current	B port	-	80	mA
T <sub>stg</sub>	Storage temperature		<sup>[2]</sup> -60	150	°C

Note:

- [1] The input and output negative voltage ratings may be exceeded if the input and output clamp current ratings are observed.
- [2] The performance capability of a high-performance integrated circuit in conjunction with its thermal environment can create junction temperatures which are detrimental to reliability. The maximum junction temperature of this integrated circuit should not exceed 150 °C.

### Operating Conditions

Symbol	Parameter	Conditions	Min.	Typ.	Max.	Unit
VCC	Supply voltage		2.3	-	3.6	V
V <sub>TT</sub>	Termination voltage <sup>[1]</sup>	Lowest voltage	0.71	0.75	0.79	V
		GTL-	0.85	0.9	0.95	V
		GTL	1.14	1.2	1.26	V
		GTL+	1.35	1.5	1.65	V
V <sub>ref</sub>	Reference voltage	overall	0.43	2/3V <sub>TT</sub>	VCC/2	V
		Lowest voltage	0.43	0.5	0.55	
		GTL-	0.5	0.6	0.63	V
		GTL	0.76	0.8	0.84	V
		GTL+	0.87	1	1.1	V
V <sub>I</sub>	Input voltage	B port	0	V <sub>TT</sub>	3.6	V
V <sub>IH</sub>	HIGH-level input voltage	B port	V <sub>ref</sub> + 0.050	-	-	V
V <sub>IL</sub>	LOW-level input voltage	B port	-	-	V <sub>ref</sub> - 0.050	V
I <sub>OL</sub>	LOW-level output current	B port	-	-	40	mA
T <sub>amb</sub>	Ambient temperature	operating in free-air	-40	-	-85	°C

Note:

[1] V<sub>TT</sub> maximum of 3.6 V with resistor sized so I<sub>OL</sub> maximum is not exceeded.

### Static Characteristics

Recommended operating conditions; voltages are referenced to GND (ground = 0 V). T<sub>amb</sub> = -40 °C to +85 °C

Symbol	Parameter	Conditions	Min.	Typ. <sup>[1]</sup>	Max.	Unit
V <sub>OL</sub>	LOW-level output voltage	B port; VCC = 3.0 V; I <sub>OL</sub> = 40 mA		0.23	0.4	V
		B port; VCC = 2.3 V; I <sub>OL</sub> = 40 mA		0.26	0.4	V
I <sub>I</sub>	Input current	B port; VCC = 3.6 V; V <sub>I</sub> = V <sub>TT</sub> or GND			±1	uA
I <sub>LO</sub>	Output leakage current	B port; VCC = 3.6 V; V <sub>O</sub> = V <sub>TT</sub>			±1	uA
ICC	Quiescent supply current	B port; VCC = 3.6 V; V <sub>I</sub> = VCC or GND; IO = 0 mA		4	8	mA
C <sub>i</sub>	Input capacitance	B port; V <sub>O</sub> = V <sub>TT</sub> or 0 V		4.5		pF
C <sub>o</sub>	Input/output capacitance	B port; V <sub>O</sub> = V <sub>TT</sub> or 0 V		5.5		pF

Note:

[1] All typical values are measured at VCC = 3.3 V and T<sub>amb</sub> = 25 °C.

[2] The input and output voltage ratings may be exceeded if the input and output current ratings are observed.

### Dynamic Characteristics

All typical values are at VCC = 3.3 V and Tamb = 25 ° C.

Symbol	Parameter	Conditions	Min.	Typ.	Max.	Unit
GTL - ; Vref = 0.5V; VTT = 0.75 V						
t <sub>PLH</sub>	LOW to HIGH propagation delay	BIn to BOn;		3.5	8	ns
t <sub>PHL</sub>	HIGH to LOW propagation delay	BIn to BOn;		6.5	10	ns
GTL - ; Vref = 0.6 V; VTT = 0.9 V						
t <sub>PLH</sub>	LOW to HIGH propagation delay	BIn to BOn;		3.5	8	ns
t <sub>PHL</sub>	HIGH to LOW propagation delay	BIn to BOn;		6.5	10	ns
GTL - ; Vref = 0.8 V; VTT = 1.2 V						
t <sub>PLH</sub>	LOW to HIGH propagation delay	BIn to BOn;		4.1	8	ns
t <sub>PHL</sub>	HIGH to LOW propagation delay	BIn to BOn;		6.5	10	ns
GTL+; Vref = 1.0 V; VTT = 1.5 V						
t <sub>PLH</sub>	LOW to HIGH propagation delay	BIn to BOn;		4.6	8	ns
t <sub>PHL</sub>	HIGH to LOW propagation delay	BIn to BOn;		6.5	10	ns

### Dynamic Characteristics

All typical values are at VCC = 2.5 V and Tamb = 25 ° C.

Symbol	Parameter	Conditions	Min.	Typ.	Max.	Unit
GTL - ; Vref = 0.5V; VTT = 0.75 V						
t <sub>PLH</sub>	LOW to HIGH propagation delay	BIn to BOn;		4.2	8	ns
t <sub>PHL</sub>	HIGH to LOW propagation delay	BIn to BOn;		8.6	12	ns
GTL - ; Vref = 0.6 V; VTT = 0.9 V						
t <sub>PLH</sub>	LOW to HIGH propagation delay	BIn to BOn;		4.4	8	ns
t <sub>PHL</sub>	HIGH to LOW propagation delay	BIn to BOn;		8.6	12	ns
GTL - ; Vref = 0.8 V; VTT = 1.2 V						
t <sub>PLH</sub>	LOW to HIGH propagation delay	BIn to BOn;		5.3	9	ns
t <sub>PHL</sub>	HIGH to LOW propagation delay	BIn to BOn;		8.9	13	ns
GTL+; Vref = 1.0 V; VTT = 1.5 V						
t <sub>PLH</sub>	LOW to HIGH propagation delay	BIn to BOn;		6.5	10	ns
t <sub>PHL</sub>	HIGH to LOW propagation delay	BIn to BOn;		9.4	14	ns

**Waveforms**

$V_M = V_{ref}$  for B ports

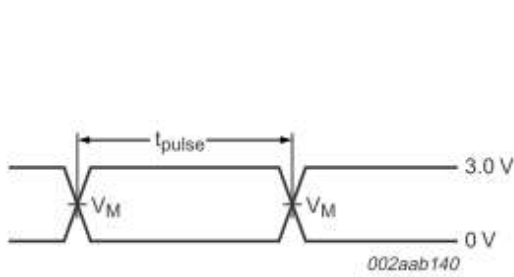

a. Pulse duration

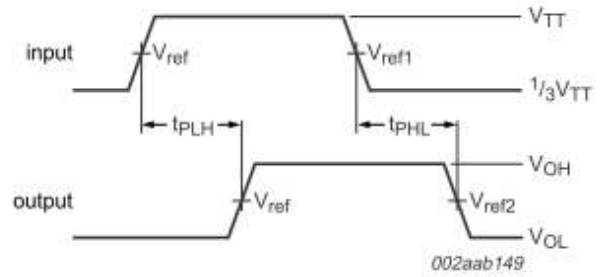

b. Propagation delay times

Fig 2. Voltage waveforms

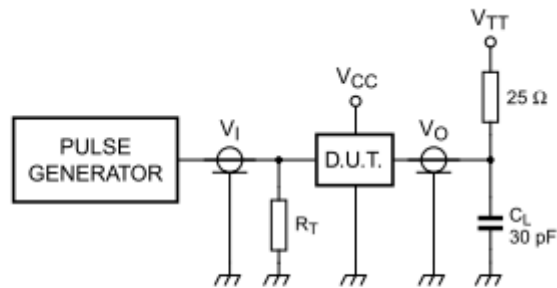

$C_L$  = load capacitance; includes jig and probe capacitance.

$R_T$  = termination resistance; should be equal to  $Z_o$  of pulse generator.

Fig 3. Load circuit for B outputs

**Part Marking**

L Package



YY: Year

WW: Workweek

1st X: Assembly Code

2nd X: Fab Code

**Package Mechanical:**  
TSSOP-14(L)

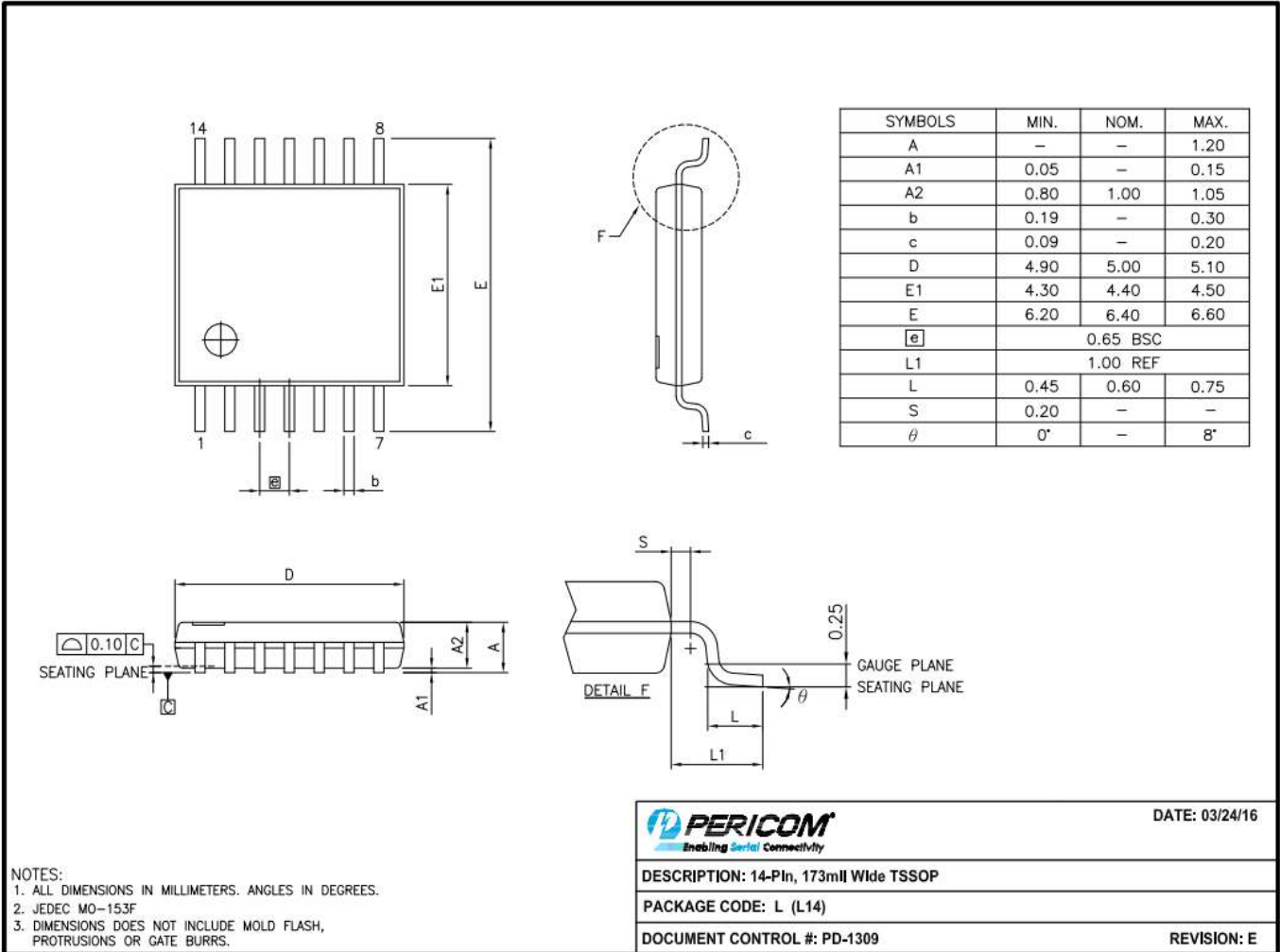

**For latest package info.**

please check: <http://www.diodes.com/design/support/packaging/pericom-packaging/packaging-mechanicals-and-thermal-characteristics/>

**Ordering Information**

Part No.	Package Code	Description
PI4GTL2034LEX	L	14-Pin, 173 mil Wide (TSSOP)

**Notes:**

- Thermal characteristics can be found on the company web site at [www.diodes.com/design/support/packaging/](http://www.diodes.com/design/support/packaging/)
- E = Pb-free and Green
- X suffix = Tape/Reel

**IMPORTANT NOTICE**

DIODES INCORPORATED MAKES NO WARRANTY OF ANY KIND, EXPRESS OR IMPLIED, WITH REGARDS TO THIS DOCUMENT, INCLUDING, BUT NOT LIMITED TO, THE IMPLIED WARRANTIES OF MERCHANTABILITY AND FITNESS FOR A PARTICULAR PURPOSE (AND THEIR EQUIVALENTS UNDER THE LAWS OF ANY JURISDICTION).

Diodes Incorporated and its subsidiaries reserve the right to make modifications, enhancements, improvements, corrections or other changes without further notice to this document and any product described herein. Diodes Incorporated does not assume any liability arising out of the application or use of this document or any product described herein; neither does Diodes Incorporated convey any license under its patent or trademark rights, nor the rights of others. Any Customer or user of this document or products described herein in such applications shall assume all risks of such use and will agree to hold Diodes Incorporated and all the companies whose products are represented on Diodes Incorporated website, harmless against all damages.

Diodes Incorporated does not warrant or accept any liability whatsoever in respect of any products purchased through unauthorized sales channel.

Should Customers purchase or use Diodes Incorporated products for any unintended or unauthorized application, Customers shall indemnify and hold Diodes Incorporated and its representatives harmless against all claims, damages, expenses, and attorney fees arising out of, directly or indirectly, any claim of personal injury or death associated with such unintended or unauthorized application.

Products described herein may be covered by one or more United States, international or foreign patents pending. Product names and markings noted herein may also be covered by one or more United States, international or foreign trademarks.

This document is written in English but may be translated into multiple languages for reference. Only the English version of this document is the final and determinative format released by Diodes Incorporated.

**LIFE SUPPORT**

Diodes Incorporated products are specifically not authorized for use as critical components in life support devices or systems without the express written approval of the Chief Executive Officer of Diodes Incorporated. As used herein:

A. Life support devices or systems are devices or systems which:

1. are intended to implant into the body, or
2. support or sustain life and whose failure to perform when properly used in accordance with instructions for use provided in the labeling can be reasonably expected to result in significant injury to the user.

B. A critical component is any component in a life support device or system whose failure to perform can be reasonably expected to cause the failure of the life support device or to affect its safety or effectiveness.

Customers represent that they have all necessary expertise in the safety and regulatory ramifications of their life support devices or systems, and acknowledge and agree that they are solely responsible for all legal, regulatory and safety-related requirements concerning their products and any use of Diodes Incorporated products in such safety-critical, life support devices or systems, notwithstanding any devices- or systems-related information or support that may be provided by Diodes Incorporated. Further, Customers must fully indemnify Diodes Incorporated and its representatives against any damages arising out of the use of Diodes Incorporated products in such safety-critical, life support devices or systems.

Copyright © 2016, Diodes Incorporated  
www.diodes.com