

# PDS-LCM2B

Dual Large Flat Panel Ceiling Mount Adaptor

## Product Features:

- Holds most 37" – 90" flat panels
- Adapts PDS-LCB (sold separately) to accommodate 2 flat panels
- Maximum flat panel hole pattern – 860mm x 500mm
- Adjustable 0° – 15° tilt
- PDS-LCB and PDS-LCM2B combined load capacity – 360 lbs
- Black powder coat finish

## Product Specifications: *(for Architects & Engineers)*

The adaptor, which will allow two ceiling mounted large flat panels, shall be the Video Mount Products (VMP) PDSL2CM2B. The adaptor shall be used in conjunction with the Video Mount Products (VMP) PDS-LCB to mount two flat panels to the ceiling or other suitable support surface. The adaptor shall be primarily constructed of formed steel and shall incorporate arc welds and nylon filled nuts. The mount shall be capable of supporting two flat panels ranging in size from 37" to 90" when combined with the PDS-LCB. The combined load capacity of the combined PDS-LCB and PDS-LCM2B shall be 360 lbs.

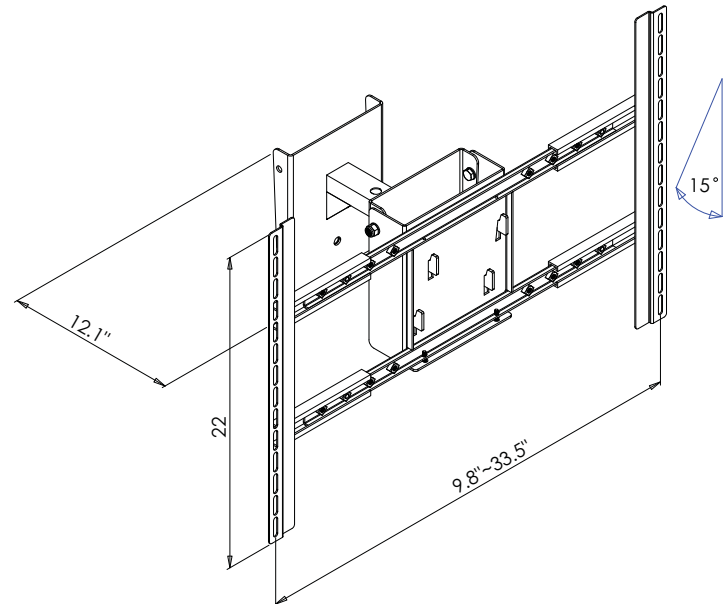

## Video Mount Products

345 Log Canoe Circle Stevensville, MD 21666  
Toll Free: 877.281.2169 Telephone: 410.643.6390  
Facsimile: 410.643.6615 [www.videomount.com](http://www.videomount.com)

**VMP**  
VIDEO MOUNT PRODUCTS