

### 6FE Square Trimmer Potentiometers

Type: **EVND**

#### ■ Features

- Top-adjust or side-adjust available
- Radial taping supported
- High reliability (dustproof construction)

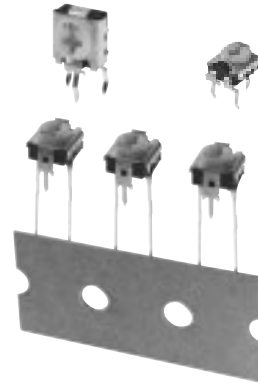

#### ■ Recommended Applications

- Audio Visual Equipment, Home Electrical Appliances

#### ■ Explanation of Part Numbers

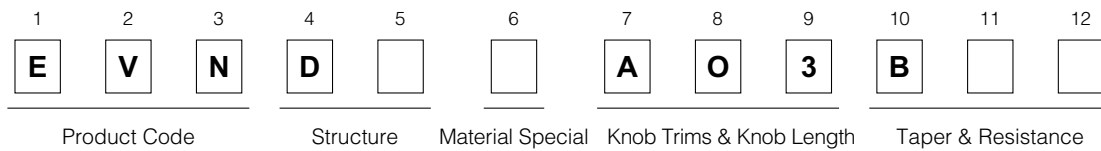

#### ■ Specifications

Electrical Specifications	Nominal Total Resistance	1 k $\Omega$ , 2 k $\Omega$ , 5 k $\Omega$ , 10 k $\Omega$ , 20 k $\Omega$ , 50 k $\Omega$ , 100 k $\Omega$ , 200 k $\Omega$ , 500 k $\Omega$ , 1 M $\Omega$
	Taper	B
	Rating	R $\leq$ 500 k $\Omega$ : 0.1 W 50 V (50 °C) R>500 k $\Omega$ : 0.1 W 25 V (50 °C)
	Residual Resistance	1 k $\Omega$ $\leq$ R $\leq$ 2 k $\Omega$ : 60 $\Omega$ max. 2 k $\Omega$ <R $\leq$ 1 M $\Omega$ : 3 % max., or 200 $\Omega$ max. whichever smaller
Mechanical Specifications	Rotation Angle	210 ° $\pm$ 20 °
	Rotation Torque	2 mN·m to 25 mN·m
	Stopper Strength	Surface : 75 mN·m, reverse side : 35 mN·m
Endurance	Operating Life	100 cycles
	Resistance to Soldering Heat	240 °C to 280 °C : 5 s max., 280 °C to 300 °C : 3 s max.
	Resistance to Damp	After 350 hours : R $\leq$ 100 k $\Omega$ +15 % -0 %, : 100 k $\Omega$ <R $\leq$ 1 M $\Omega$ +20 % -0 %
	Endurance under Damp	After 350 hours : 1.5 h ON 0.5 h OFF : R $\leq$ 100 k $\Omega$ $\pm$ 15 %, : 100 k $\Omega$ <R $\leq$ 1 M $\Omega$ $\pm$ 20 %
	Endurance under High Temperature	70 °C $\pm$ 3 °C After 250 hours +5 %, -15 %
Minimum Quantity/Packing Unit		EVND2A, EVND8A : 500 pcs. Polyethylene Bag (Bulk) EVNDJA, EVNDXA, EVNDCA : 1000 pcs. Radial Taping (Reel Pack)
Quantity/Carton		EVND2A, EVND8A : 5000 pcs. EVNDJA, EVNDXA, EVNDCA : 10000 pcs.

Note : R=Nominal Total Resistance

Design and specifications are each subject to change without notice. Ask factory for the current technical specifications before purchase and/or use. Should a safety concern arise regarding this product, please be sure to contact us immediately.

■ Dimensions in mm (not to scale)

● Side-adjust ..... EVND2A

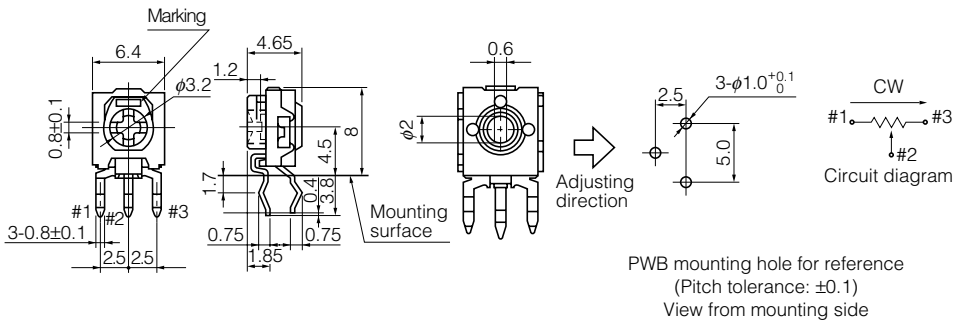
<p>No. 1</p> 	 <p style="text-align: center;">Adjusting direction</p> <p style="text-align: center;">PWB mounting hole for reference (Pitch tolerance: ±0.1) View from mounting side</p> <table border="1" style="width: 100%; margin-top: 10px; border-collapse: collapse;"> <tr> <td style="width: 50%;">Knob color</td> <td style="width: 50%;">Orange yellow</td> </tr> </table>	Knob color	Orange yellow
Knob color	Orange yellow		

● Top-adjust ..... EVND8A

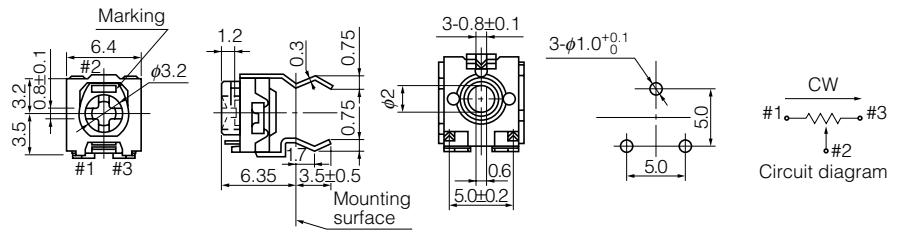
<p>No. 2</p> 	 <p style="text-align: center;">PWB mounting hole for reference (Pitch tolerance: ±0.1) View from mounting side</p> <table border="1" style="width: 100%; margin-top: 10px; border-collapse: collapse;"> <tr> <td style="width: 50%;">Knob color</td> <td style="width: 50%;">Orange yellow</td> </tr> </table>	Knob color	Orange yellow
Knob color	Orange yellow		

