

QT-Brightek Chip LED Series

SMD 1206 LED

Part No.: QBLP650 series

Table of Contents:

Introduction	3
Electrical / Optical Characteristic (Ta=25 °C)	4
Absolute Maximum Rating	4
CIE Chromaticity Table	6
Characteristic Curves	7
Solder Profile & Footprint	9
Packing	10
Labeling	11
Ordering Information	11
Revision History	12
Disclaimer	12

Introduction

Feature:

- Water clear lens
- Package in tape and reel
- Bright 1206 LED package
- InGaN technology for IB/IG/IW
- AllnGaP technology for R/AG/Y/O

Description:

This top mount bright 1206 LEDs have a height profile of 1.1mm, which is ideal in any kind of back lighting application. Also, it is a light weight model that is good for miniature products.

Application:

- Automotive dashboard lighting and button lighting
- Telecommunication and storage Back lighting
- Flat panel display back lighting

Certification & Compliance:

- TS16949
- ISO9001
- RoHS Compliant



Dimension:

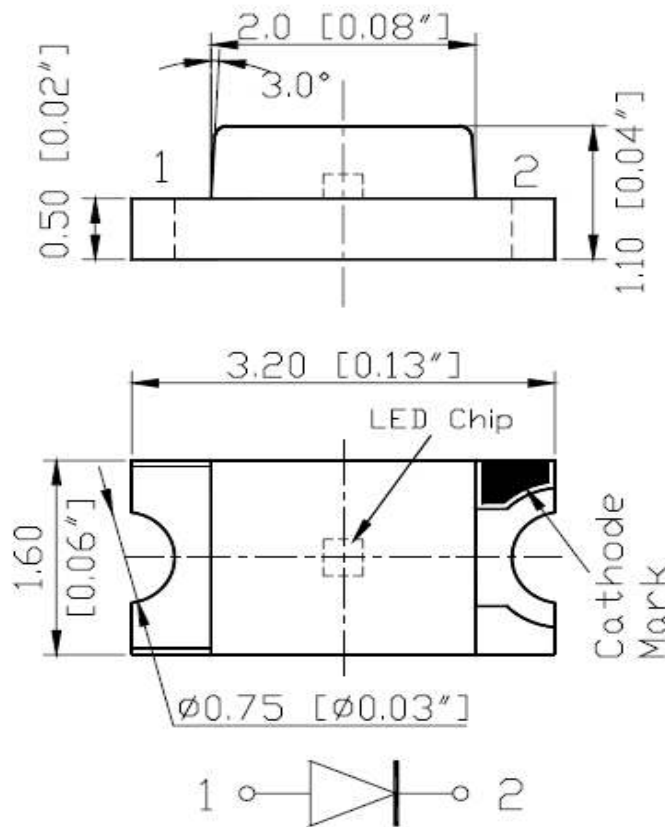

Units: mm / tolerance = +/-0.1mm

Electrical / Optical Characteristic (Ta=25 °C)

Product	Color	I _F (mA)	V _F (V)		λ _D (nm)			I _V (mcd)	
			Typ.	Max.	Min.	Typ.	Max	Min.	Typ.
QBLP650-IB	Blue	20	3.2	3.7	465	470	475	40	70
QBLP650-IG	Green	20	3.3	3.7	520	525	530	250	420
QBLP650-IW	White	20	3.3	3.7	X=0.25 Y=0.24	X=0.29 Y=0.30	X=0.33 Y=0.34	200	380
QBLP650-R	Red	20	2.0	2.5	615	620	630	80	170
QBLP650-AG	Yellow Green	20	2.0	2.5	565	570	576	25	40
QBLP650-Y	Yellow	20	2.0	2.5	585	590	595	80	150
QBLP650-O	Orange	20	2.0	2.5	600	605	610	125	210

Absolute Maximum Rating

Material	P _d (mW)	I _F (mA)	I _{FP} (mA)*	V _R (V)	T _{OP} (°C)	T _{ST} (°C)	T _{SOL} (°C)**
InGaN	111	30	125	5	-40 ~ +80	-40 ~ +85	260
AllnGaP	75	30	125	5	-40 ~ +80	-40 ~ +85	260

*Duty 1/8 @ 1kHz

**IR Reflow for no more than 10 sec @ 260°C

Forward Voltage V_F for AllnGaP @ I_F=20mA

Bin	Min.	Max.	Unit
□	1.7	2.5	V

Forward Voltage V_F for InGaN @ I_F=20mA

Bin	Min.	Max.	Unit
f	2.8	3.1	V
g	3.1	3.4	
h	3.4	3.7	

Dominant Wavelength λ_D for Blue @ I_F=20mA

Bin	Min.	Max.	Unit
G	465	467.5	nm
H	467.5	470	
I	470	472.5	
J	472.5	475	

Dominant Wavelength λ_D for Green @ I_F=20mA

Bin	Min.	Max.	Unit
U	520	522.5	nm
V	522.5	525	
W	525	527.5	
X	527.5	530	

Dominant Wavelength λ_D for Red @ $I_F=20mA$

Bin	Min.	Max.	Unit
s	615	620	nm
t	620	625	
u	625	630	

Dominant Wavelength λ_D for Yellow Green @ $I_F=20mA$

Bin	Min.	Max.	Unit
h	565	568	nm
i	568	572	
j	572	576	

Dominant Wavelength λ_D for Yellow @ $I_F=20mA$

Bin	Min.	Max.	Unit
m	585	590	nm
n	590	595	

Dominant Wavelength λ_D for Orange @ $I_F=20mA$

Bin	Min.	Max.	Unit
p	600	605	nm
q	605	610	

Luminous Intensity I_V @ $I_F=20mA$

Bin	Min.	Max.	Unit
C	20	25	mcd
D	25	32	
E	32	40	
F	40	50	
G	50	63	
H	63	80	
I	80	100	
J	100	125	
K	125	160	
L	160	200	
M	200	250	
N	250	320	
O	320	400	
P	400	500	
Q	500	630	

CIE Chromaticity Table

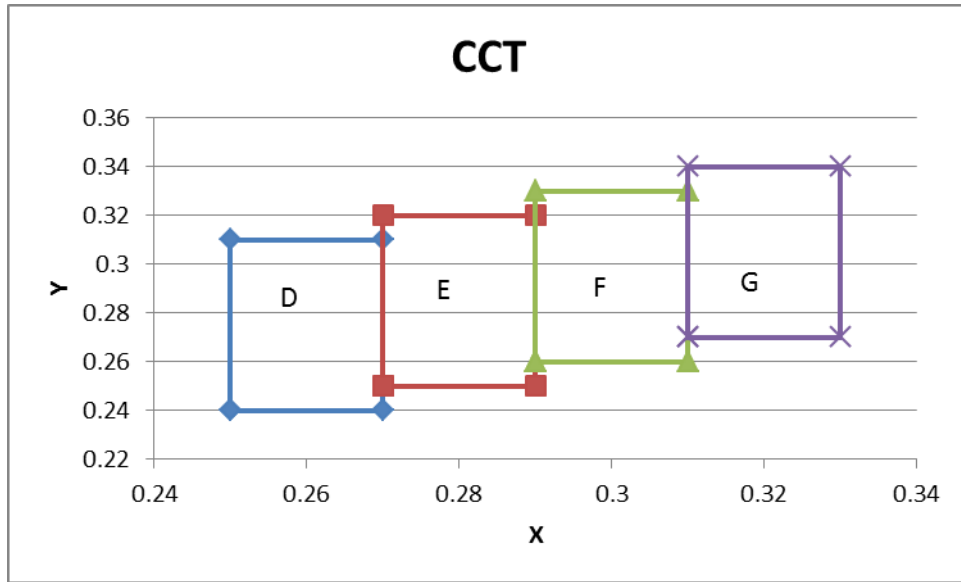

D		E		F		G	
0.25	0.24	0.27	0.25	0.29	0.26	0.31	0.27
0.25	0.31	0.27	0.32	0.29	0.33	0.31	0.34
0.27	0.31	0.29	0.32	0.31	0.33	0.33	0.34
0.27	0.24	0.29	0.25	0.31	0.26	0.33	0.27
0.25	0.24	0.27	0.25	0.29	0.26	0.31	0.27

Characteristic Curves

InGaN Technology (IB/IG/IW)

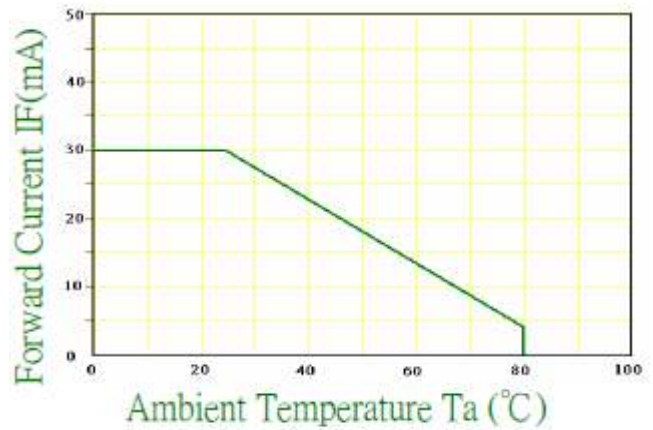
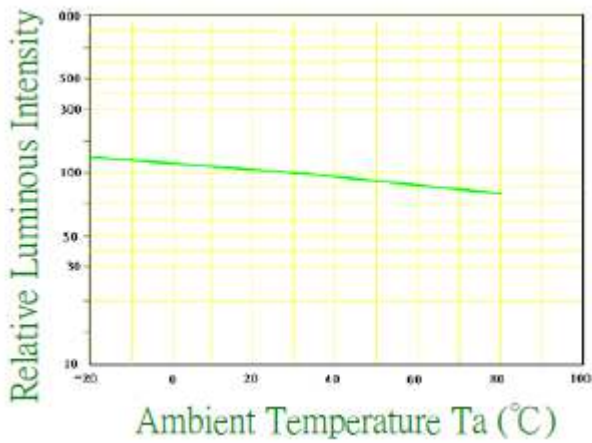
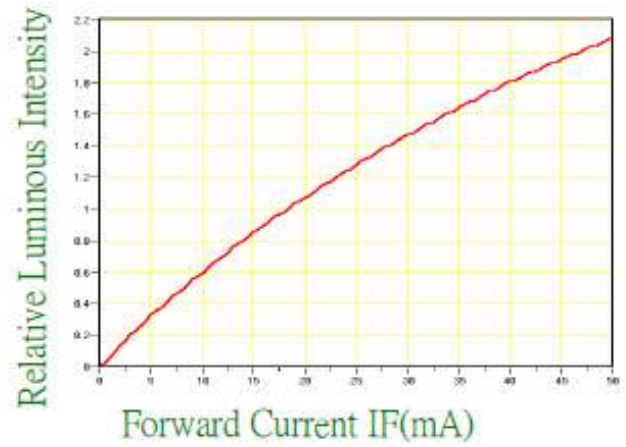
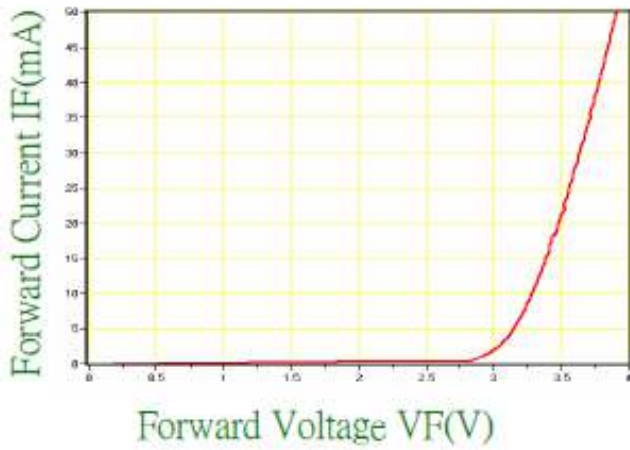

Directive Characteristics

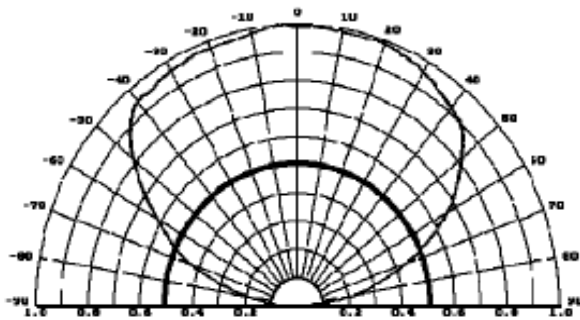

Relative Intensity vs. Wavelength

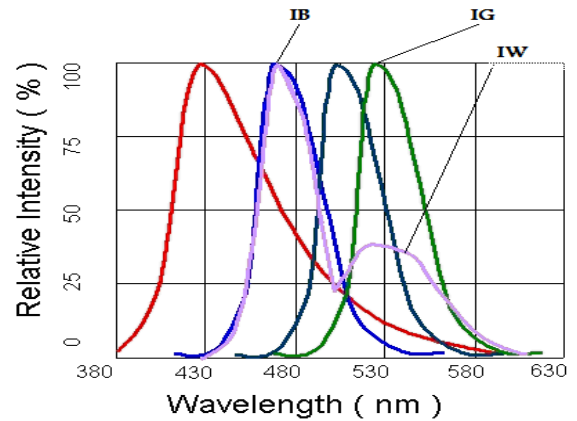

AllnGaP Technology (R/AG/Y/O)

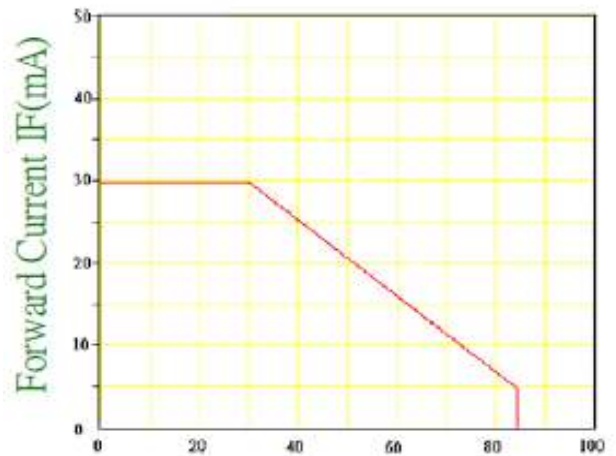
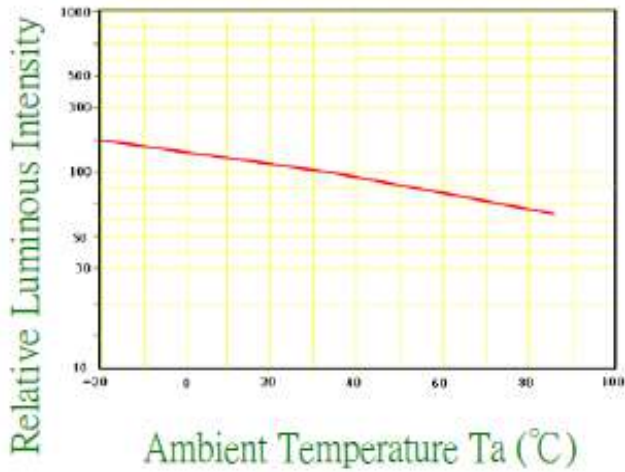
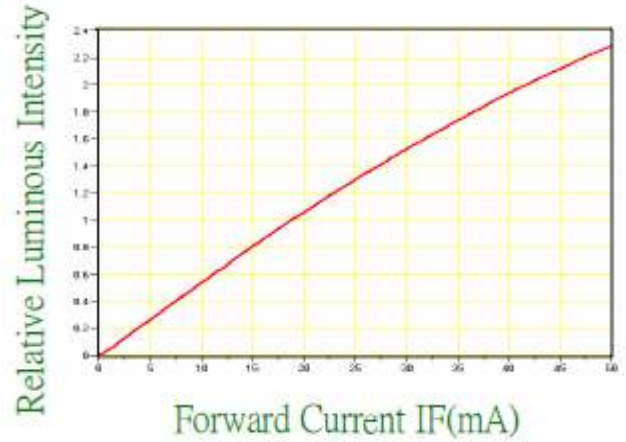
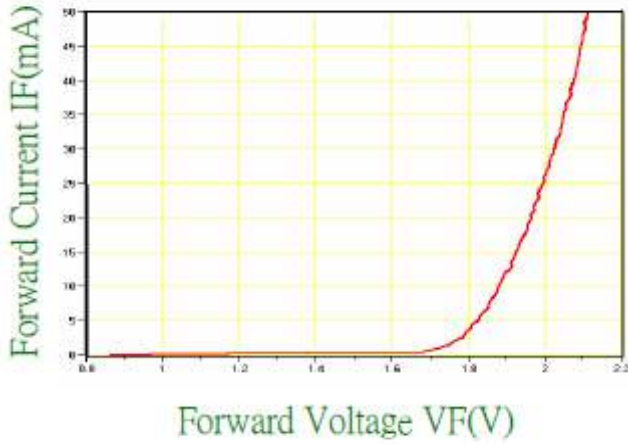

Directive Characteristics

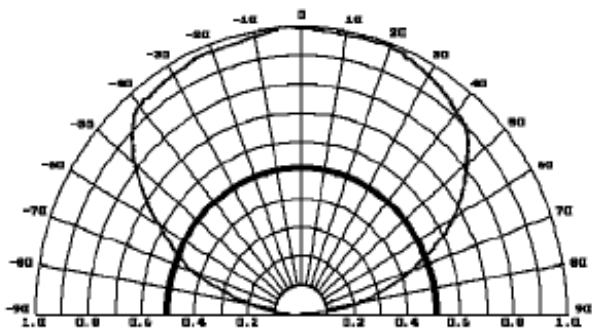

Relative Intensity vs. Wavelength

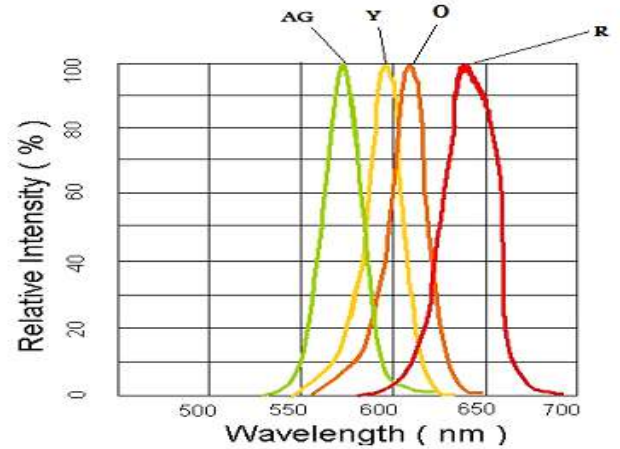

Solder Profile & Footprint

IR Reflow Soldering Profile
Lead Free Solder

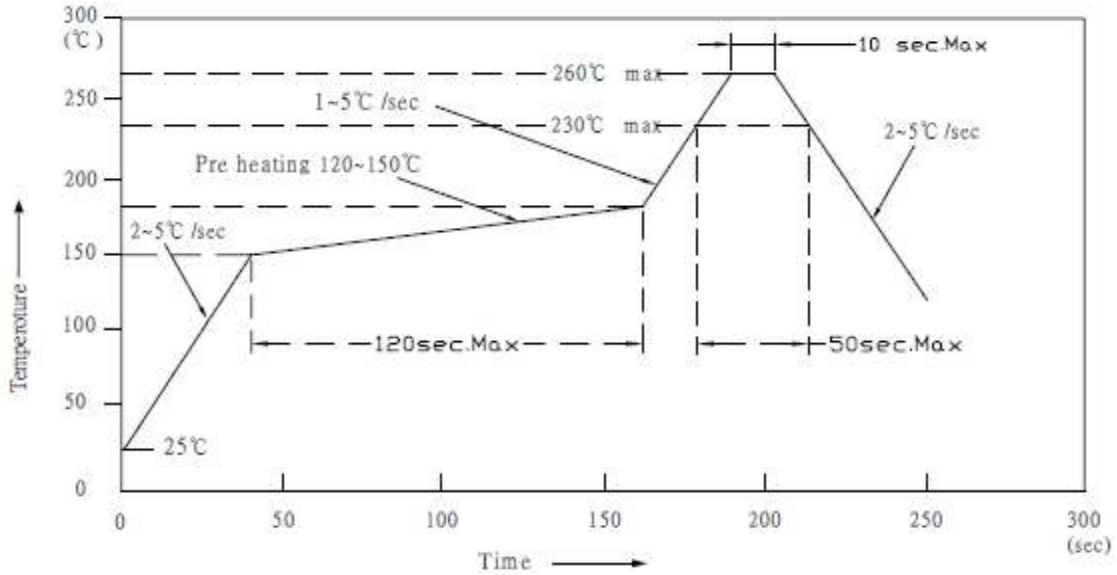

For reflow soldering (propose)

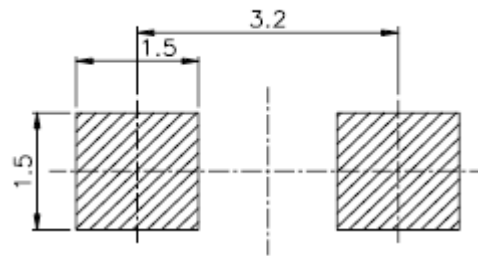

(Proposed Solder footprint)

Units: mm

tolerance: +/- 0.1mm

Packing

Reel Dimension:

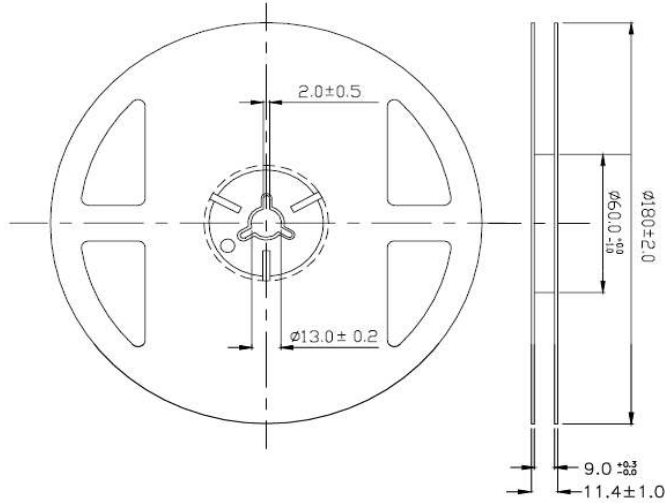

Unit: mm

Tape Dimension:

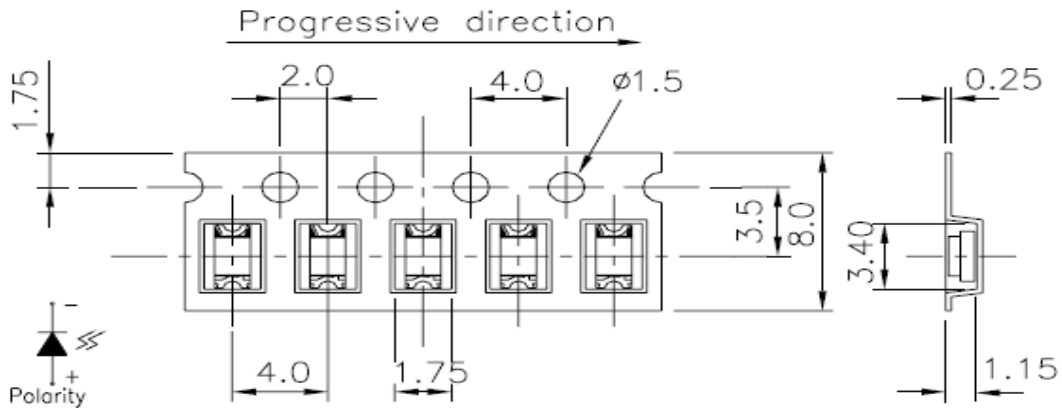

Unit: mm

Arrangement of Tape:

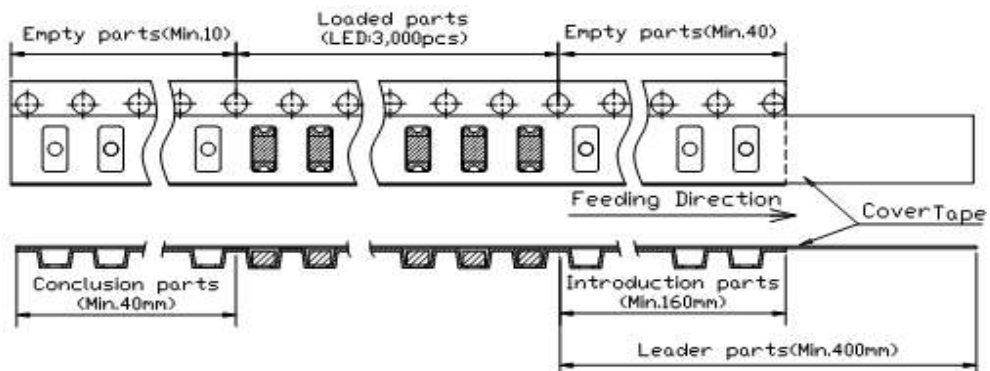

Labeling



Part No: _____
 Customer P/N: _____
 Item: _____
 Q'ty: _____
 Vf: _____
 Iv: _____
 VI: _____
 Date: _____

Made in China

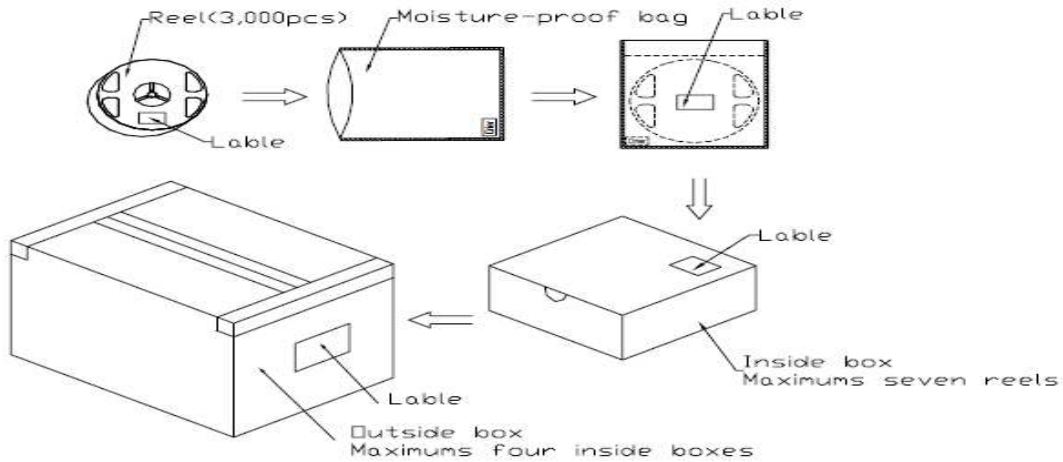

Ordering Information

Part #	Orderable Part #	Spec Range	Quantity per reel
QBLP650-IB	QBLP650-IB	Iv = 70 mcd Typ. / Color = 470nm Typ.	3,000 units
QBLP650-IG	QBLP650-IG	Iv = 420 mcd Typ. / Color = 525nm Typ.	3,000 units
QBLP650-IW	QBLP650-IW	Iv = 380 mcd Typ. / (X = 0.28, Y = 0.29) Typ.	3,000 units
QBLP650-R	QBLP650-R	Iv = 170 mcd Typ. / Color = 615 – 630nm	3,000 units
QBLP650-AG	QBLP650-AG	Iv = 40 mcd Typ. / Color = 570nm Typ.	3,000 units
QBLP650-Y	QBLP650-Y	Iv = 150 mcd Typ. / Color = 590nm Typ.	3,000 units
QBLP650-O	QBLP650-O	Iv = 210 mcd Typ. / Color = 605nm Typ.	3,000 units

Revision History

Description:	Revision #	Revision Date
New Release of QBLP650_series	V1.0	09/20/2010
Update Information	V1.1	03/20/2011
Update brightness and CCT range	V2.1	05/06/2011
Update Brightness	V2.2	06/15/2011
Add bin code	V2.3	08/16/2011
Update Spec	V2.4	12/07/2011
Update Spec	V2.5	01/24/2012
Update format	V3.0	06/04/2012



Disclaimer

QT-BRIGHTTEK reserves the right to make changes without further notice to any products herein to improve reliability, function or design. QT-BRIGHTTEK does not assume any liability arising out of the application or use of any product or circuit described herein; neither does it convey any license under its patent rights, nor the rights of others.

Life Support Policy

QT-BRIGHTTEK's products are not authorized for use as critical components in life support devices or systems without the express written approval of QT-BRIGHTTEK. As used herein:

1. Life support devices or systems are devices or systems which, (a) are intended for surgical implant into the body, or (b) support or sustain life, and (c) whose failure to perform when properly used in accordance with instructions for use provided in the labeling, can be reasonably expected to result in a significant injury of the user.
2. A critical component in any component of a life support device or system whose failure to perform can be reasonably expected to cause the failure of the life support device or system, or to affect its safety or effectiveness.