

THIS DRAWING IS UNPUBLISHED.		RELEASED FOR PUBLICATION		
COPYRIGHT 20 BY TYCO ELECTRONICS CORPORATION. ALL RIGHTS RESERVED.				
PART NUMBER	REV	FIRST USED	POWER UNIT	FEED TYPE
1855140-1	A	122500-1	LEADMAKER & BENCH MODEL G	POST FEED
1855140-2	B	565435-5	BENCH MODEL K	POST FEED
7-1855140-7	A	-	SPARE PARTS	-

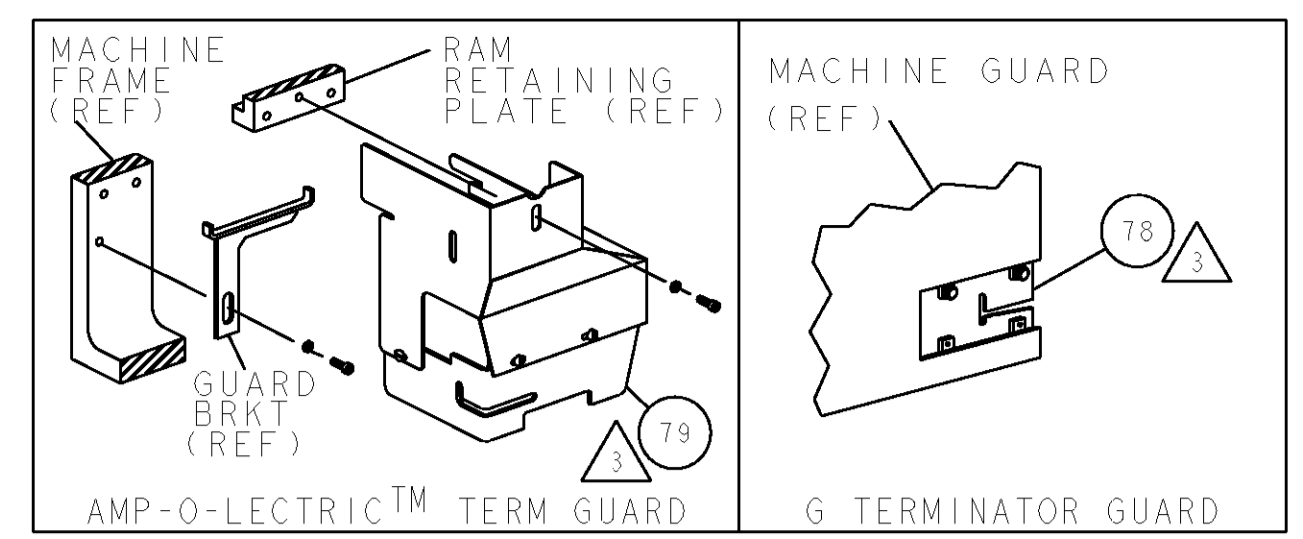

TERMINAL NAME: SAW TOOTH				
AMP P/N	INARCA P/N	INMARCA TERMINAL - AMP CRIMP SPECS		REF SETTING*
1949185	0011138201			
-	-	CRIMP HEIGHT	WIRE SIZE	
-	-	.052±.002 [1.32±0.05mm]	0.75mm ²	C5
-	-	.046±.002 [1.17±0.05mm]	0.50mm ²	E0
-	-	-	-	-
-	-	CRIMP	SIZE	TYPE
-	-	-	-	-
-	-	WIRE	.062 [1.57mm]	0
-	-	INSUL	-	-
WIRE STRIP LENGTH	TERM APPL SPEC	FEED	APPL INSTRUCTIONS	SET UP GAGE
.278 -.293	NONE	.333	408-8039	458637-1

LOC	DIST	REVISIONS					
A	66	P	LTN	DESCRIPTION	DATE	DWN	APVD
		B		ECR-07-005611	17APR2007	RK	GB

- ⚠ RECOMMENDED SPARE PARTS
- ⚠ GREASE LIGHTLY
- ⚠ GUARD MUST BE IN PLACE WHEN OPERATING APPLICATOR IN A BENCH MACHINE

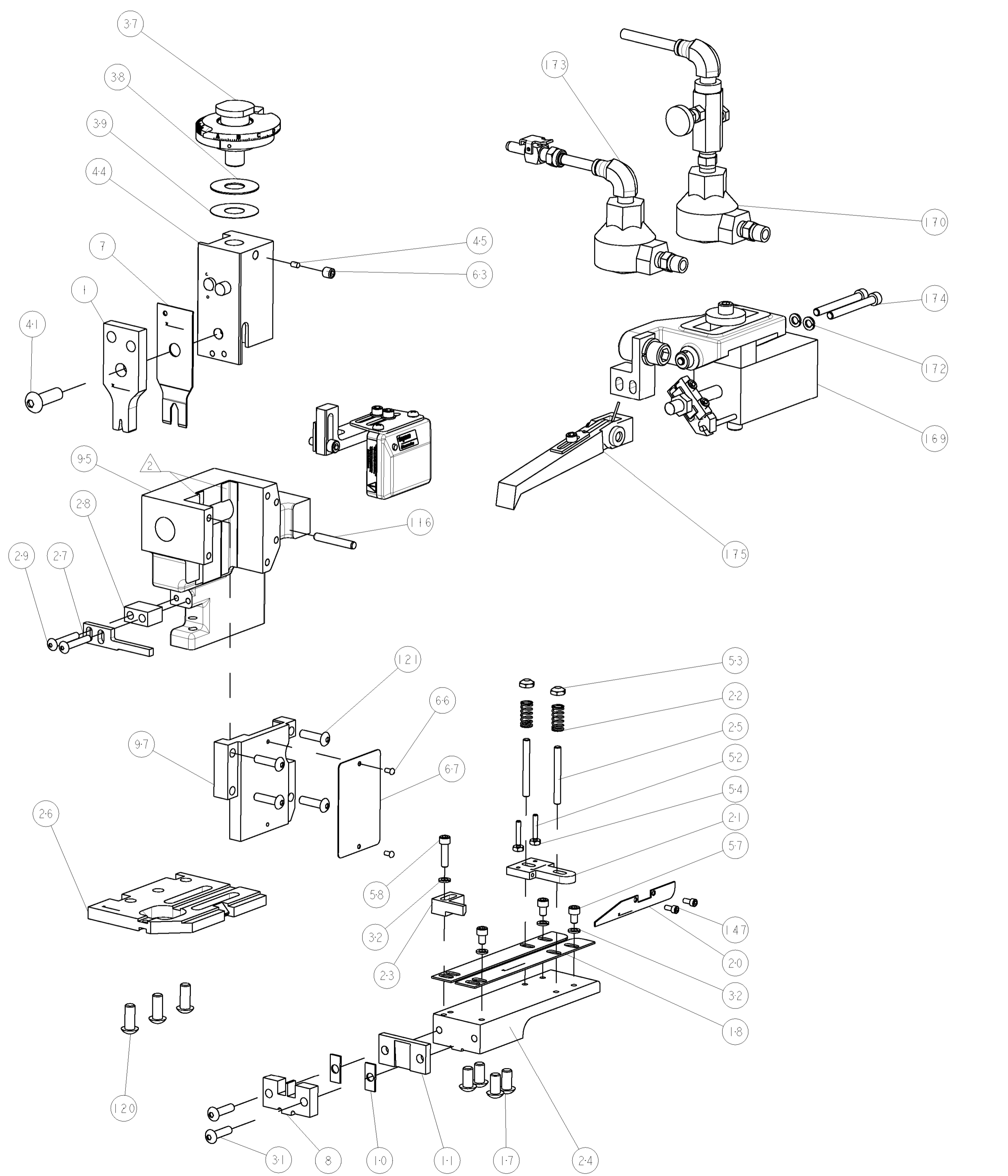

*WARNING:
ON INSTALLATION, SET WIRE DISC TO LARGEST WIRE SIZE SETTING. USE OF SETTINGS BELOW MIN REQUIRED CRIMP HEIGHT SETTING WILL CAUSE DAMAGE TO CRIMP TOOLING.

-	1	1	-	460680-2	FEED FINGER ASSEMBLY	175
-	2	2	-	4-21000-2	SCR, SKT HD CAP 10-32 X 1.750	174
-	-	1	-	692655-7	AIR FEED VALVE ASSEMBLY	173
-	2	2	-	21024-5	WASHER, SPRG LOCK, REG NO 10	172
-	1	-	-	692655-5	AIR FEED VALVE ASSEMBLY	170
-	1	1	-	460277-1	AIR FEED ASSY	169
-	2	2	-	1-21000-3	SCR, SKT HD CAP 4-40 X .250	147
-	4	4	-	2-21002-9	SCR, BTN SKT HD CAP 10-32 X .750	121
-	3	3	-	2-22733-8	SCR, BHSC, SELF-LOCKING, 1/4-20 X .625	120
-	1	1	-	1-21030-6	PIN, DOWEL .1875 X 1.250	116
-	1	1	-	454220-1	CAP, RAM	97
-	1	1	-	453736-1	HOUSING, APPLICATOR	95
-	REF	-	-	455745-1	GUARD WINDOW	79
-	-	REF	-	679532-1	INSERT, GUARD	78
-	1	1	-	217238-1	GENERAL INSTRUCTION PKG	72
-	1	1	-	4088039	EF APPL INST 408-8039	71
-	1	1	-	461264-1	PLATE, IDENTIFICATION	67
-	2	2	-	21017-2	SCREW, DRIVE	66
-	1	1	-	21009-2	SCR, SET, SELF LOCKING 1/4-20 X .250	63
-	1	1	-	2-21000-8	SCR, SKT HD CAP 8-32 X .625	58
-	3	3	-	2-21000-5	SCR, SKT HD CAP 8-32 X .250	57
-	2	2	-	21018-4	NUT, HEX, REG 4-40	54
-	2	2	-	21022-2	NUT, LOCK, HEX, TORQUE, 8-32	53
-	2	2	-	2-21006-6	SCR, SET, CUP POINT 4-40 X .625	52
-	1	1	-	690191-1	PLUG, NYLON	45
-	1	1	-	455674-5	RAM	44
-	1	1	-	7-21002-9	SCR, BTN SKT HD CAP 5/16-24 X 1.00	41
-	1	1	-	690125-1	SHIM SUB-ASSY	39
-	1	1	-	469367-8	SHIM	38
-	1	1	-	879103-4	FINE ADJUST HEAD SUBASSY	37
-	4	4	-	21024-4	WASHER, SPRG LOCK, REG NO 8	32
-	2	2	-	2-21002-9	SCR, BTN SKT HD CAP 10-32 X .750	31
-	2	2	-	8-21002-9	SCR, BTN SKT HD CAP 8-32 X 1.00	29
-	1	1	-	1-690451-6	SPACER, STRIPPER	28
-	1	1	-	690455-1	STRIPPER, FRONT CASTING	27
-	1	1	-	459717-1	PLATE, BASE	26
-	2	2	-	22354-8	STUD, THREADED	25
-	1	1	-	455678-1	PLATE, STRIP GUIDE	24
-	1	1	-	240825-1	PLATE, STRIP HOLD DOWN	23
-	2	2	-	2-22281-3	SPRING, COMPRESSION	22
-	1	1	-	464451-1	ARM, STOCK DRAG	21
-	1	1	-	464452-5	DRAG, STOCK	20
-	2	2	-	454204-7	GUIDE, LOWER STRIP	18
-	4	4	-	3-21002-3	SCR, BTN SKT HD CAP 1/4-20 X .500	17
-	1	1	-	240644-1	PLATE, REAR SHEAR	11
-	2	2	-	240645-2	SPACER, SHEAR PLATE	10
-	1	1	-	5-690618-0	ANVIL, SPLICE TYPE	8
-	1	1	-	1-459722-6	BLADE, SHEAR	7
-	1	1	-	5-459492-6	CRIMPER, WIRE O	1

- ⚠
- ⚠
- ⚠
- ⚠

DIMENSIONS: INCHES		TOLERANCES UNLESS OTHERWISE SPECIFIED:		DWN: B. KNEPPER 07NOV2006		Tyco Electronics Harrisburg, PA 17105-3608	
0 PLC ±.01		1 PLC ±.01		CHK: G. BAILEY 07DEC2006		NAME: END FEED HDM APPLICATOR	
2 PLC ±.01		3 PLC ±.001		APVD: J. BENCHOFF 07NOV2006		PRODUCT SPEC: -	
4 PLC ±.0001		ANGLES ±.001		FINISH: -		APPLICATION SPEC: -	
MATERIAL: -		FINISH: -		WEIGHT: -		SIZE: CAGE CODE: DRAWING NO: A1 00779 C=1855140	
CUSTOMER DRAWING		SCALE: 3:5		SHEET: 1 OF 1		REV: B	