



FocusLCDs.com
LCDs MADE SIMPLE®

Ph. 480-503-4295 | NOPP@FocusLCD.com

TFT | CHARACTER | UWVD | FSC | SEGMENT | CUSTOM | REPLACEMENT

TFT Display Module

Part Number

E104RB-FW450-N

Overview:

- 10.4-inch TFT (288.92x41.5mm)
- 24-bit RGB Interface
- 1024x100 pixels
- Top View
- Wide Temp
- Transmissive/ Normally White
- No Touch Screen
- 450 NITS
- Controller: HX8282-A/HX8678-C
- RoHS Compliant

Description

This is a color active matrix TFT (Thin Film Transistor) LCD (Liquid Crystal Display) that uses amorphous silicon TFT as a switching device. This model is composed of a transmissive type TFT-LCD Panel, driver circuit and backlight unit. The resolution of the 10.4" TFT-LCD contains 1024x100 pixels and can display up to 16.7M colors.

Features

Low Input Voltage: 3.3V (TYP)

Display Colors: 16.7M colors

TFT Interface: 24-bit RGB

| General Information Items | Specification | Unit | Note |
|---------------------------|----------------------------------|---------|------|
| | Main Panel | | |
| TFT Display Area (AA) | 264.192(W) x 35.8(H) (10.4 inch) | mm | - |
| Driver Element | TFT active matrix | - | - |
| Display Colors | 16.7M | colors | - |
| Number of Pixels | 1024(RGB)x100 | dots | - |
| TFT Pixel Arrangement | RGB vertical stripe | - | - |
| Pixel Pitch | 0.258 (W) x 0.258 (H) | mm | - |
| Viewing Angle | 12 (Gray inversion: 6) | o'clock | - |
| TFT Controller IC | HX8282-A*1, HX8678-C*1 | - | - |
| Display Mode | Transmissive/Normally White | - | - |
| Polarizer | Anti-Glare (Haze:25%) | - | - |
| Hardness | 3H | - | - |
| Operating Temperature | -20~+70 | °C | - |
| Storage Temperature | -30~+80 | °C | - |

Mechanical Information

| Item | | Typ. | Unit | Note |
|-------------|------------|--------|------|------|
| Module Size | Width (W) | 288.92 | mm | - |
| | Height (H) | 41.5 | mm | - |
| | Depth (D) | 4.2 | mm | - |
| Weight | | TBD | g | - |

Note: Without FPC

1. Block Diagram

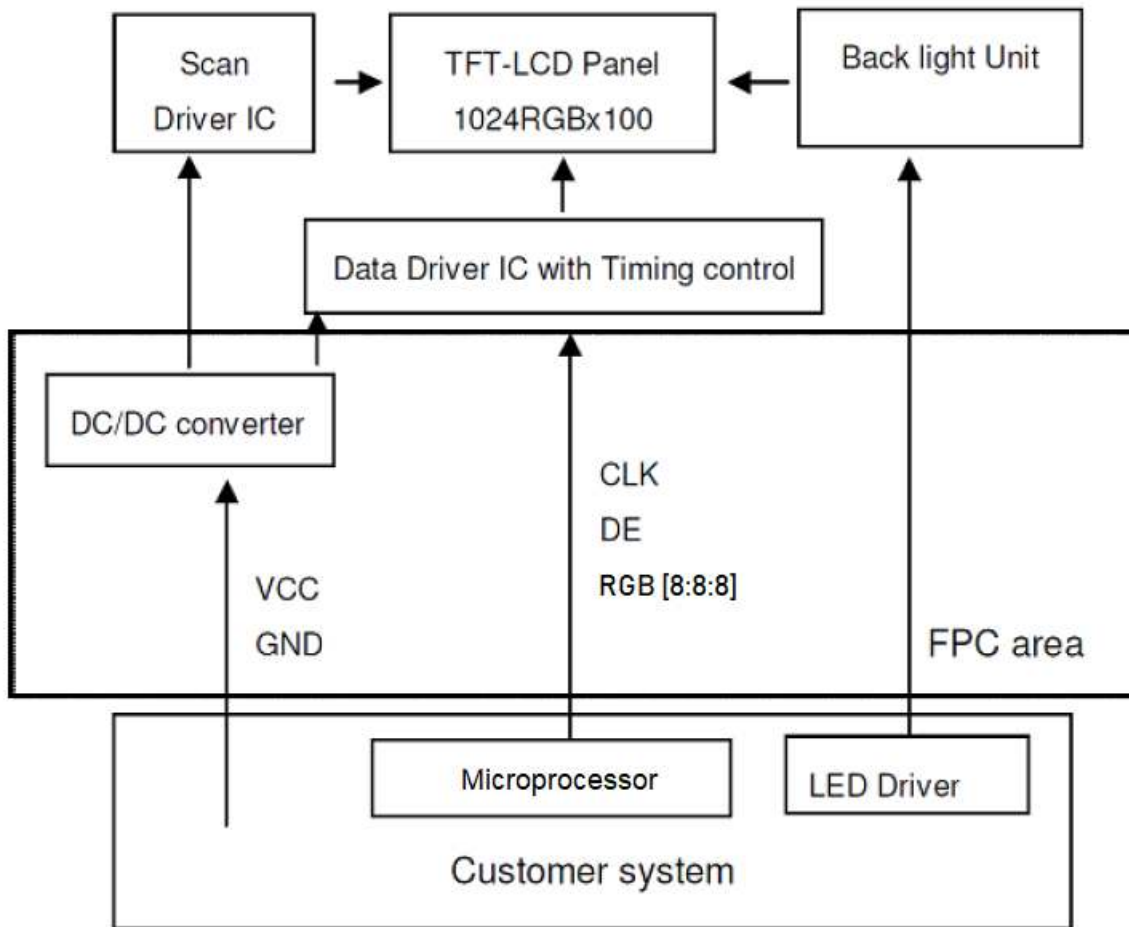

2. Outline Dimensions

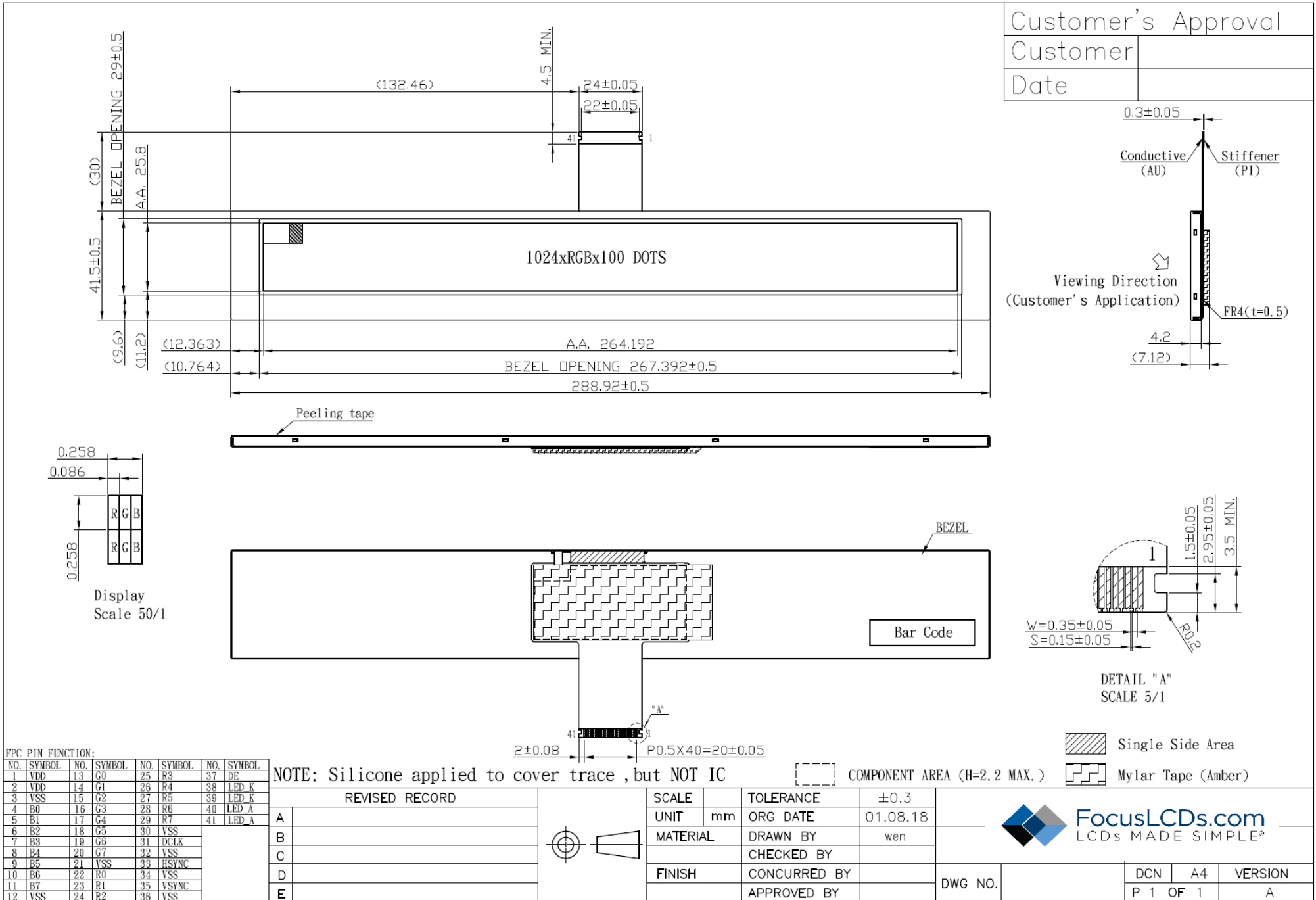

3. Input Terminal Pin Assignment

Recommended Connector: XF3M-4115-1B

| NO. | Symbol | Description | I/O |
|-----|--------|--|-----|
| 1 | VDD | Power Supply | P |
| 2 | VDD | | P |
| 3 | VSS | Power Ground | P |
| 4 | B0 | Blue 8-bit data bus | I |
| 5 | B1 | | I |
| 6 | B2 | | I |
| 7 | B3 | | I |
| 8 | B4 | | I |
| 9 | B5 | | I |
| 10 | B6 | | I |
| 11 | B7 | | I |
| 12 | VSS | Power Ground | P |
| 13 | G0 | Green 8-bit data bus | I |
| 14 | G1 | | I |
| 15 | G2 | | I |
| 16 | G3 | | I |
| 17 | G4 | | I |
| 18 | G5 | | I |
| 19 | G6 | | I |
| 20 | G7 | | I |
| 21 | VSS | Power Ground | P |
| 22 | R0 | Red 8-bit data bus | I |
| 23 | R1 | | I |
| 24 | R2 | | I |
| 25 | R3 | | I |
| 26 | R4 | | I |
| 27 | R5 | | I |
| 28 | R6 | | I |
| 29 | R7 | | I |
| 30 | VSS | Power Ground | P |
| 31 | DCLK | Clock signal for RGB interface operation | I |
| 32 | VSS | Power Ground | P |
| 33 | HSYNC | Horizontal sync input | I |
| 34 | VSS | Power Ground | P |
| 35 | VSYNC | Vertical sync input | I |
| 36 | VSS | Power Ground | P |
| 37 | DE | Data enable input | I |
| 38 | LED_K | Cathode pin of backlight | P |
| 39 | LED_K | | P |
| 40 | LED_A | Anode pin of backlight | P |
| 41 | LED_A | | P |

I: Input, O: Output, P: Power

4. LCD Optical Characteristics

4.1 Optical Specifications

| Item | Symbol | Condition | Min | Typ. | Max | Unit | Note | |
|------------------------------|--------|---------------------------------------|------------|-------|-------|--------|--------|--------|
| Contrast Ratio | CR | Normal Viewing Angle $\theta=0$ | 200 | 300 | -- | -- | (2) | |
| Response Time | TR+TF | | -- | 25 | 50 | ms | (4) | |
| NTSC | S(%) | | 39 | -- | -- | % | (5) | |
| Color Filter Chromaticity | White | | W_x | 0.287 | 0.337 | 0.387 | -- | (5)(6) |
| | | | W_y | 0.298 | 0.348 | 0.398 | | |
| | Red | | R_x | 0.528 | 0.578 | 0.628 | | |
| | | | R_y | 0.283 | 0.333 | 0.383 | | |
| | Green | | G_x | 0.343 | 0.393 | 0.443 | | |
| | | | G_y | 0.493 | 0.543 | 0.593 | | |
| | Blue | | B_x | 0.108 | 0.158 | 0.208 | | |
| | | B_y | 0.092 | 0.142 | 0.192 | | | |
| Viewing Angle | Hor. | θ_L | 9 o'clock | -- | 60 | degree | (1)(6) | |
| | | θ_R | 3 o'clock | -- | 60 | | | |
| | Ver. | θ_T | 12 o'clock | -- | 50 | | | |
| | | θ_B | 6 o'clock | -- | 60 | | | |
| Option View Direction | FREE | | | | | | (1) | |

4.2 Measuring Conditions

Measuring surrounding: dark room

Ambient temperature: $25 \pm 2^\circ\text{C}$

15 min. warm-up time

Optical Specification Reference Notes:

(1) Definition of Viewing Angle: The viewing angle is the angle at which the contrast ratio is greater than 10. The viewing angles are determined for the horizontal or 3,9 o'clock direction and the vertical or 6,12 o'clock direction with respect to the optical axis which is normal to the LCD surface.

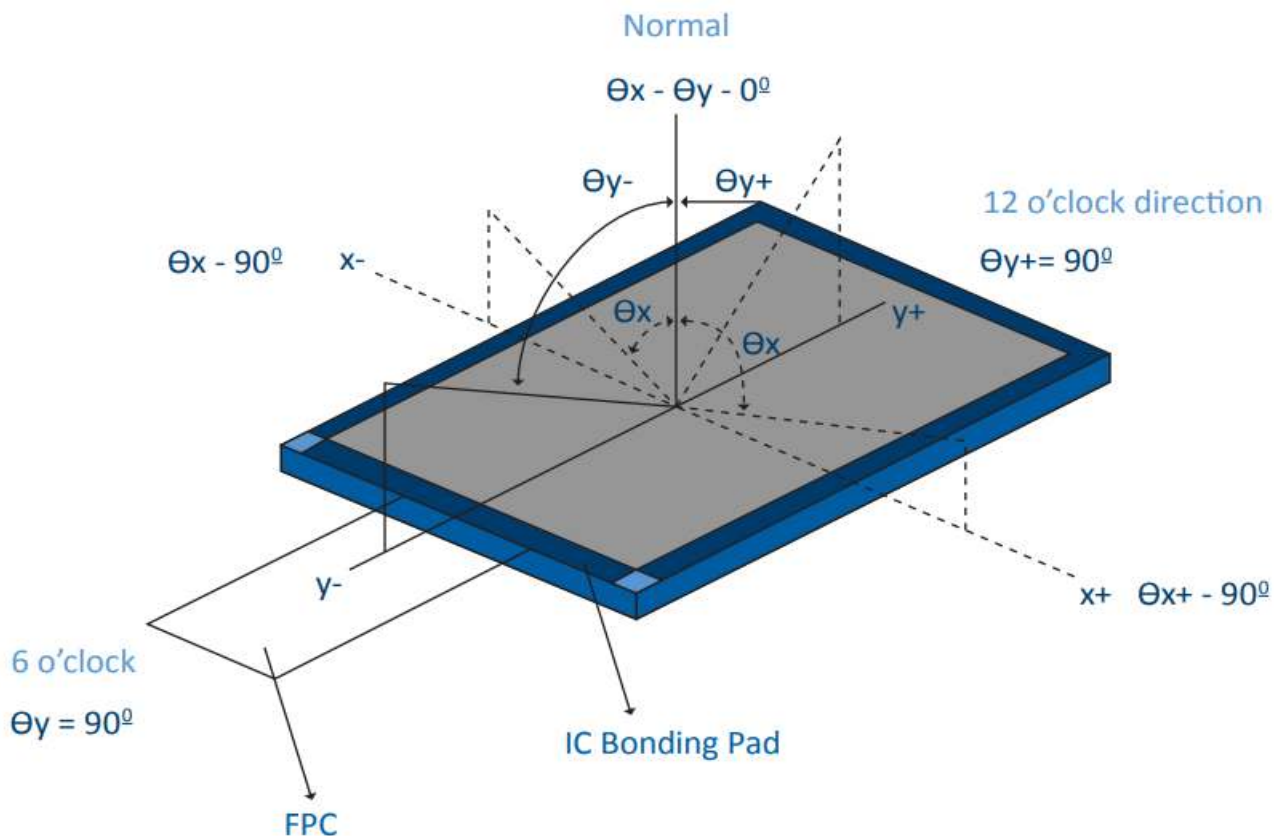
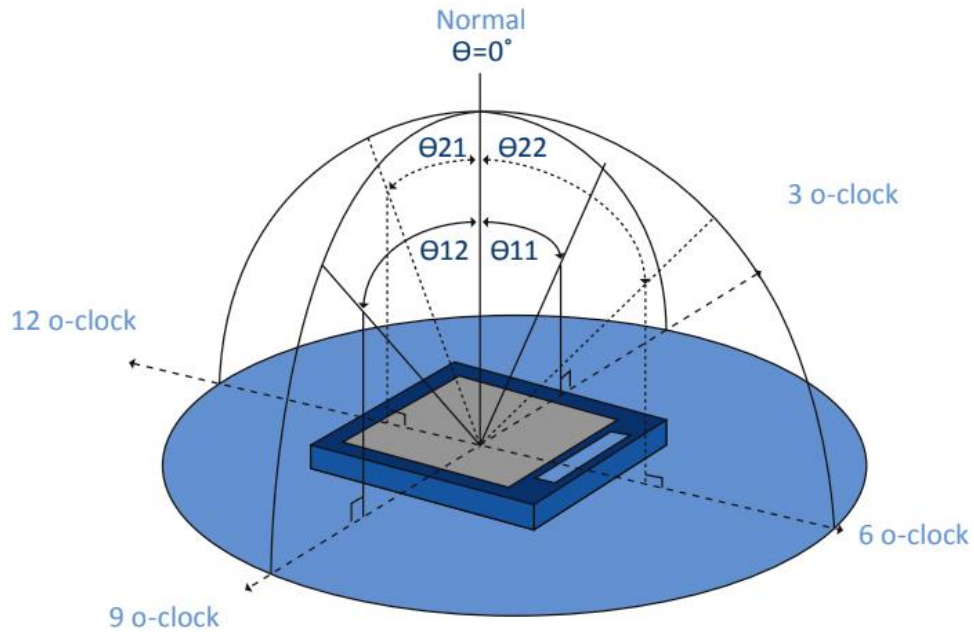

(2) Definition of Contrast Ratio (Cr): measured at the center point of panel. The contrast ratio (Cr) measured on a module, is the ratio between the luminance (Lw) in a full white area (R=G=B=1) and the luminance (Ld) in a dark area (R=G=B=0).

$$Cr = \frac{L_w}{L_d}$$

(3) Definition of transmittance (T%): The transmittance of the panel including the polarizers is measured with electrical driving.

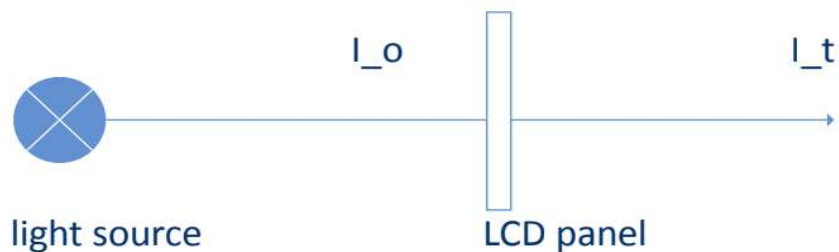

The transmittance is defined as:

$$Tr = \frac{I_t}{I_o} \times 100\%$$

I_o = the brightness of the light source.

I_t = the brightness after panel transmission

(4) Definition of Response Time (Tr, Tf): The rise time 'Tr' is defined as the time for luminance to change from 90% to 10% as a result of a change of the electrical condition. The fall time 'Tf' is defined as the time for luminance to change from 10% to 90% as a result of a change of the electrical condition.

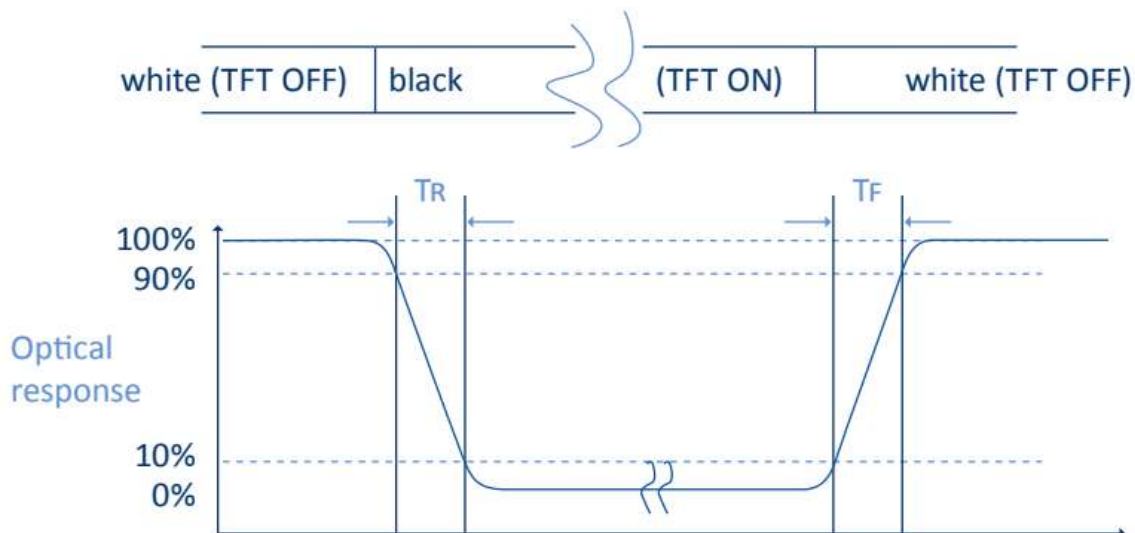

(5) Definition of Color Gamut: Measuring machine CFT-01. NTSC's Primaries: R(x,y,Y),G(x,y,Y), B(x,y,Y). FPM520 of Westar Display Technologies, INC., which utilized SR-3 for Chromaticity and BM-5A for other optical characteristics. The color chromaticity shall be calculated from the spectral data measured with all pixels first in red, green, blue and white. Measurements shall be made at the center of the panel.

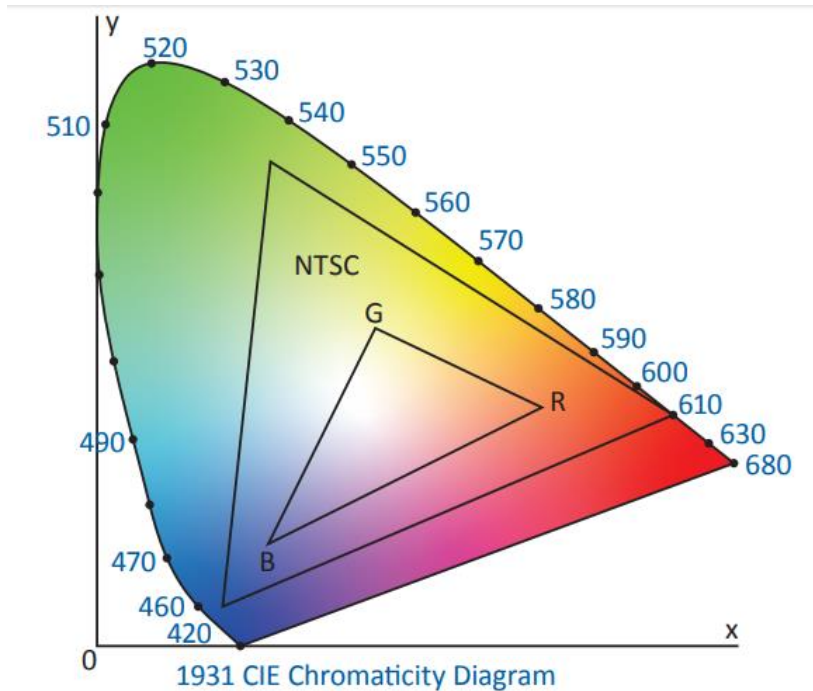
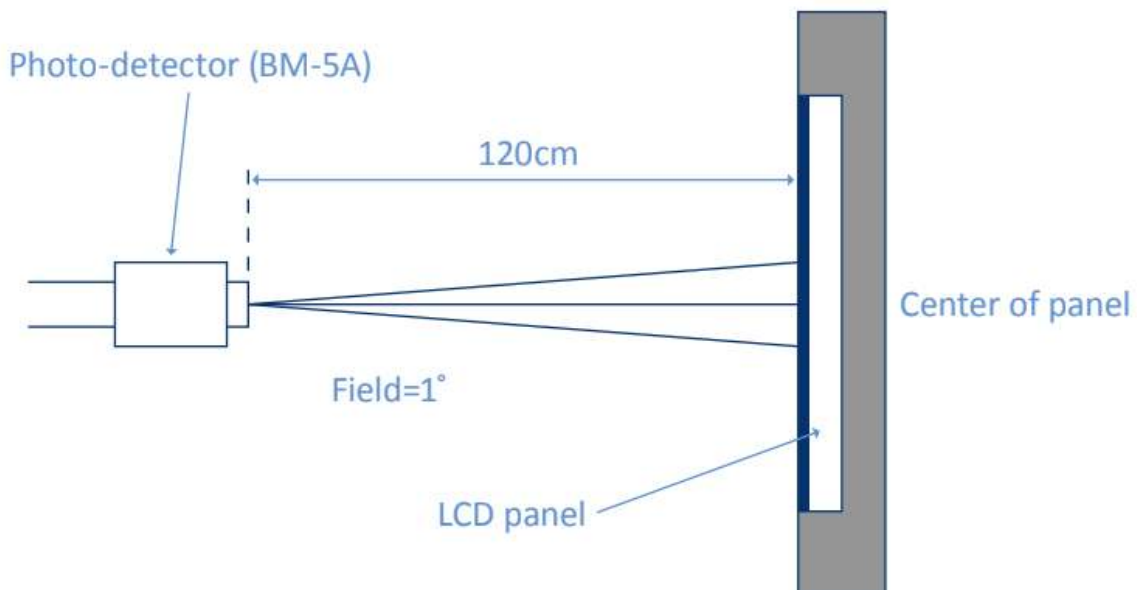

Fig. 1931 CIE chromacity diagram

$$\text{Color gamut: } S = \frac{\text{Area of RGB triangle}}{\text{Area of NTSC triangle}} \times 100\%$$

(6) Definition of Optical Measurement Setup:



(6) Optical Measurement Setup Continued:

The LCD module should be stabilized at a given temperature for 20 minutes to avoid abrupt temperature change during measuring. In order to stabilize the luminance, the measurement should be executed after lighting backlight for 20 minutes.

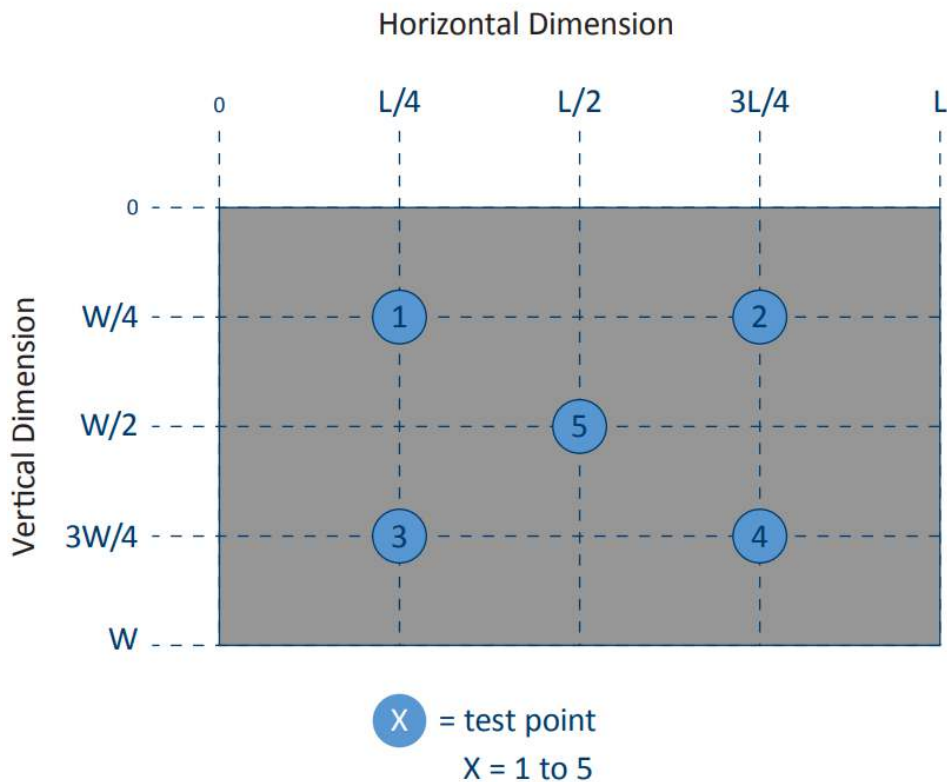
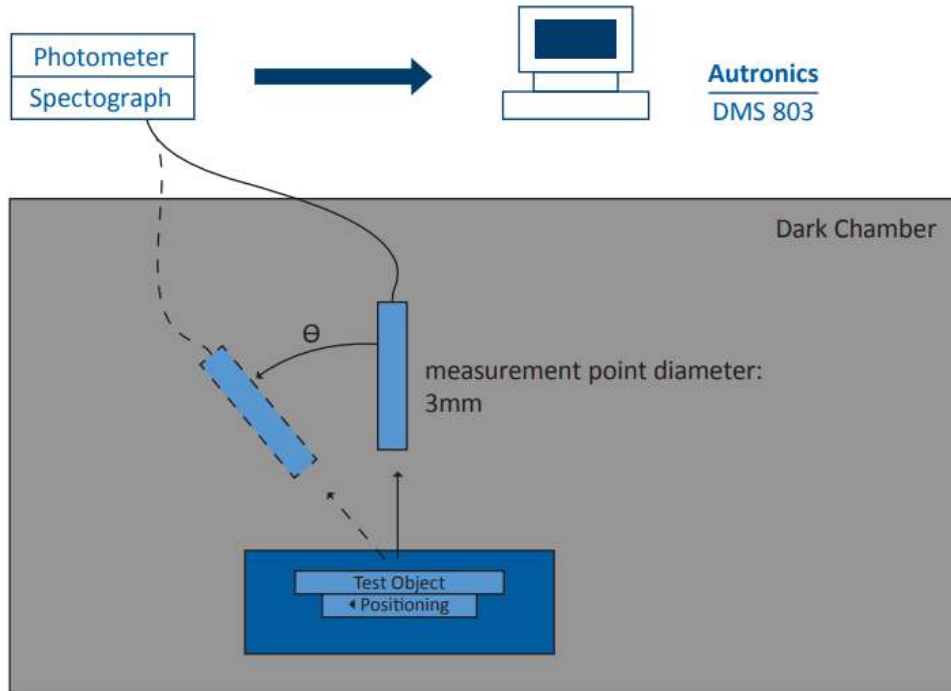

5. TFT Electrical Characteristics

5.1 Absolute Maximum Rating (Ta=25 °C, VSS=0V)

| Characteristics | Symbol | Min | Max | Unit |
|------------------------|--------|------|------|------|
| Digital Supply Voltage | VDD | -0.3 | 3.96 | V |
| Operating Temperature | TOP | 0 | +50 | °C |
| Storage Temperature | TST | -10 | +60 | °C |
| Humidity | Hstg | - | 90 | %RH |

NOTE: If the absolute maximum rating of the above parameters is exceeded, even momentarily, the quality of the product may be degraded. Absolute maximum ratings specify the values which the product may be physically damaged if exceeded. Be sure to use the product within the range of the absolute maximum ratings.

5.2 DC Electrical Characteristics

| Characteristics | Symbol | Min | Typ. | Max | Unit | Note |
|-----------------------------|--------|--------|------|--------|------|------|
| LCD Power Supply Voltage | VDD | 3.2 | 3.3 | 3.4 | V | |
| LCD Power Supply Current | Idd | -- | -- | TBD | mA | |
| Driver Input Signal Voltage | VIH | 0.7VDD | -- | VDD | V | |
| | VIL | GND | -- | 0.3VDD | V | |

5.3 LED Backlight Characteristics

| Characteristics | Symbol | Min | Typ. | Max | Unit | Note |
|--------------------|--------------------|------|------|------|------|------|
| Power Consumption | PLED | -- | -- | 1728 | mW | |
| LED Supply Voltage | VLED | 15.6 | -- | 21.6 | V | |
| LED Supply Current | ILED | -- | 80 | 80 | mA | |
| LED Rush Current | | -- | -- | 120 | mA | |
| Luminous Color | White | | | | | |
| LED Lifetime | 25°C / L50: 200000 | | | | | Hrs |

The back-light system is edge-lighting type with 12 chips White LED

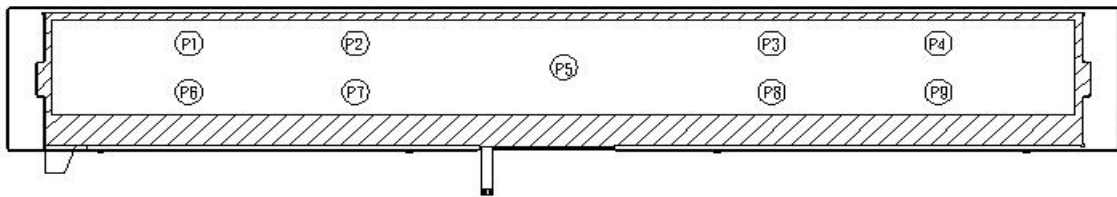

Note 1: LED lifetime (Hr) can be defined as the time in which it continues to operate under the condition: $T_a=25 \pm 3^\circ\text{C}$, typical IL value indicated in the above table until the brightness becomes less than 50%.

Note 2: The "LED lifetime" is defined as the module brightness decrease to 50% original brightness at $T_a=25^\circ\text{C}$ and $I_L = 80\text{mA}$. The LED lifetime could be decreased if operating I_L is larger than 80mA. The constant current driving method is suggested.

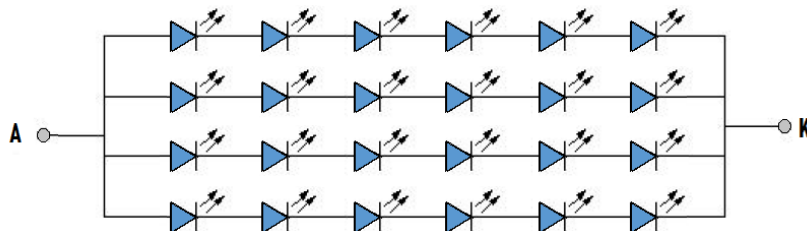

LED Backlight Circuit

Note 3: Luminance Uniformity of these 9 points is defined as below:

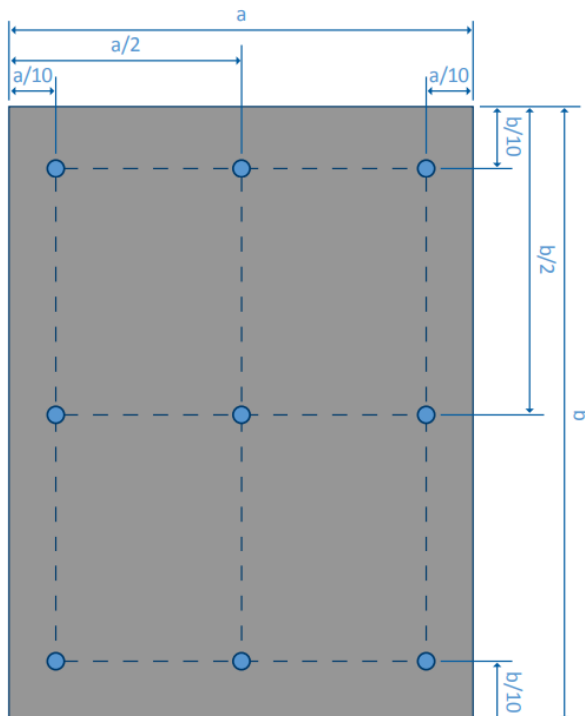

$$\text{Luminance} = \frac{\text{Total Luminance of 9 points}}{9}$$

$$\text{Uniformity} = \frac{\text{minimum luminance in 9 points(1-9)}}{\text{maximum luminance in 9 points(1-9)}}$$

6. AC Timing Characteristics

6.1 SYNC Mode

Vertical Timing

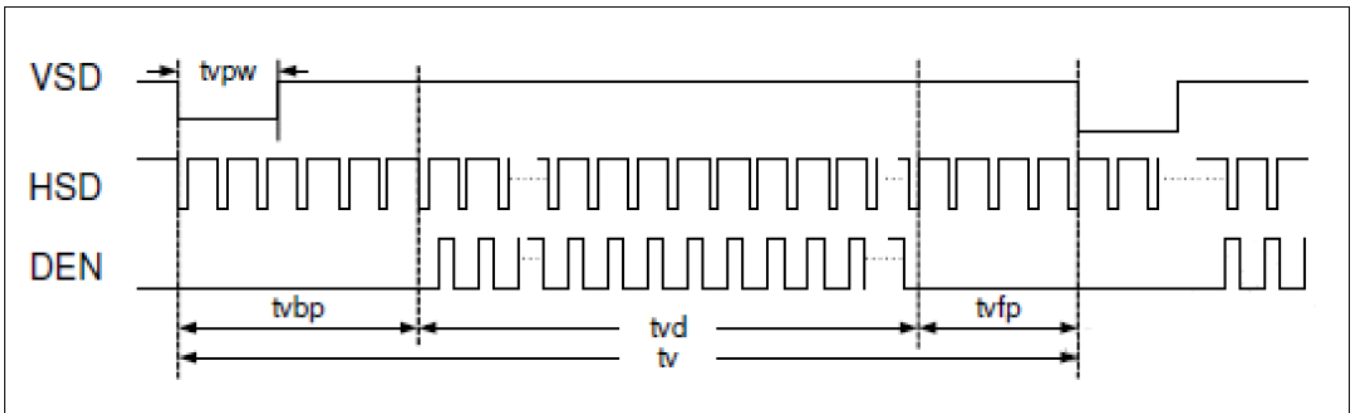

Figure 6.1: Sync-Mode Vertical Timing Diagram

Horizontal Timing

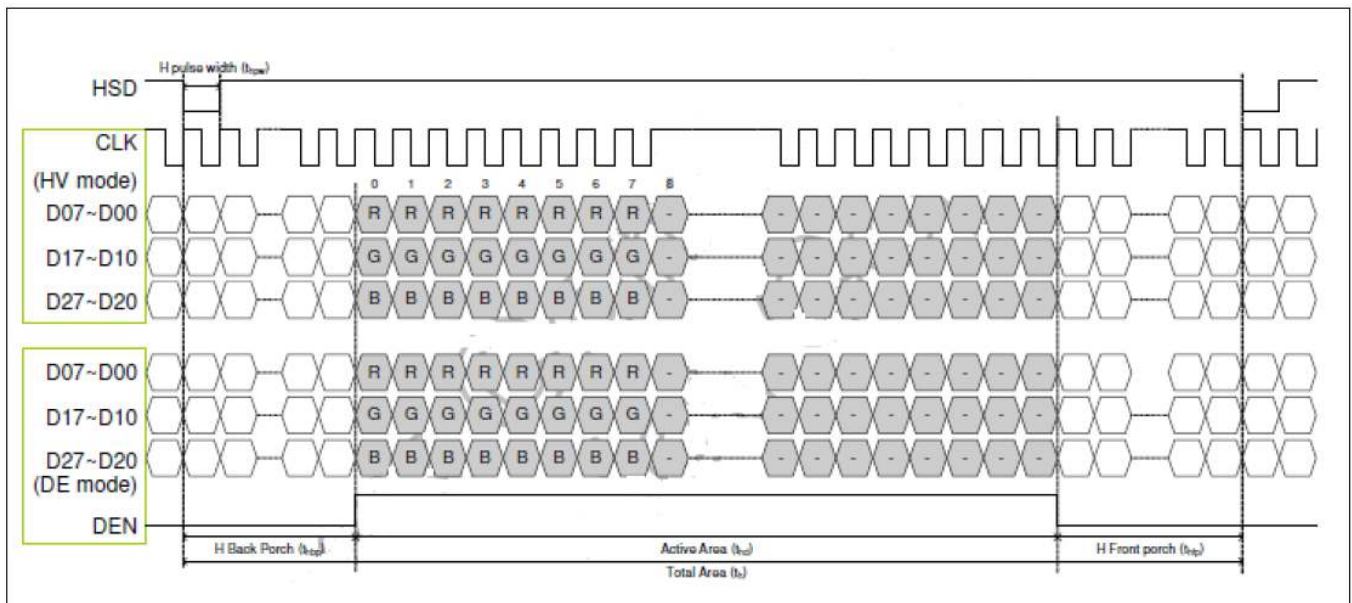

Figure 6.2: Sync-Mode Horizontal Timing Diagram



| Parameter | Symbol | Min | Typ. | Max | Unit | |
|----------------|---------------|-------|------|------|------|------|
| Frame Rate | FR | -- | 60.2 | -- | Hz | |
| DCLK Frequency | FDCLK | -- | 21 | -- | MHz | |
| Horizontal | Total line | tH | -- | 1344 | -- | DCLK |
| | Active pixels | tHact | 1024 | | | DCLK |
| | Back porch | tHBP | -- | 158 | -- | DCLK |
| | Pulse width | tHPW | -- | 1 | -- | DCLK |
| | Front porch | tHFP | -- | 161 | -- | DCLK |
| Vertical | Total time | tV | -- | 258 | -- | H |
| | Active lines | tVact | 130 | | | H |
| | Back porch | tVBP | -- | 21 | -- | H |
| | Pulse width | tVPW | -- | 2 | -- | H |
| | Front porch | tVFP | -- | 105 | -- | H |

Table 6.1: HX8282A SYNC Mode Timing Table



| Parameter | Symbol | Min | Typ. | Max | Unit | |
|----------------|---------------|-------|------|------|------|------|
| Frame Rate | FR | -- | 60.2 | -- | Hz | |
| DCLK Frequency | FDCLK | -- | 21 | -- | MHz | |
| Horizontal | Total line | tH | -- | 1344 | -- | DCLK |
| | Active pixels | tHact | 1024 | | | DCLK |
| | Back porch | tHBP | -- | 158 | -- | DCLK |
| | Pulse width | tHPW | -- | 1 | -- | DCLK |
| | Front porch | tHFP | -- | 161 | -- | DCLK |
| Vertical | Total time | tV | -- | 259 | -- | H |
| | Active lines | tVact | 130 | | | H |
| | Back porch | tVBP | -- | 57 | -- | H |
| | Pulse width | tVPW | -- | 2 | -- | H |
| | Front porch | tVFP | -- | 70 | -- | H |

Table 6.2: HX8282A SYNC Mode Timing Table

Note: Back porch is not included in pulse width

7. Cautions and Handling Precautions

7.1 Handling and Operating the Module

1. When the module is assembled, it should be attached to the system firmly. Do not warp or twist the module during assembly work.
2. Protect the module from physical shock or any force. In addition to damage, this may cause improper operation or damage to the module and back-light unit.
3. Note that polarizer is very fragile and could be easily damaged. Do not press or scratch the surface.
4. Do not allow drops of water or chemicals to remain on the display surface. If you have the droplets for a long time, staining and discoloration may occur.
5. If the surface of the polarizer is dirty, clean it using some absorbent cotton or soft cloth.
6. The desirable cleaners are water, IPA (Isopropyl Alcohol) or Hexane. Do not use ketene type materials (ex. Acetone), Ethyl alcohol, Toluene, Ethyl acid or Methyl chloride. It might permanent damage to the polarizer due to chemical reaction.
7. If the liquid crystal material leaks from the panel, it should be kept away from the eyes or mouth. In case of contact with hands, legs, or clothes, it must be washed away thoroughly with soap.
8. Protect the module from static; it may cause damage to the CMOS ICs.
9. Use fingerstalls with soft gloves in order to keep display clean during the incoming inspection and assembly process.
10. Do not disassemble the module.
11. Protection film for polarizer on the module shall be slowly peeled off just before use so that the electrostatic charge can be minimized.
12. Pins of I/F connector shall not be touched directly with bare hands.
13. Do not connect, disconnect the module in the "Power ON" condition.
14. Power supply should always be turned on/off by the item Power On Sequence & Power Off Sequence

7.2 Storage and Transportation.

1. Do not leave the panel in high temperature, and high humidity for a long time. It is highly recommended to store the module with temperature from 0 to 35 °C and relative humidity of less than 70%
2. Do not store the TFT-LCD module in direct sunlight.
3. The module shall be stored in a dark place. When storing the modules for a long time, be sure to adopt effective measures for protecting the modules from strong ultraviolet radiation, sunlight, or fluorescent light.
4. It is recommended that the modules should be stored under a condition where no condensation is allowed. Formation of dewdrops may cause an abnormal operation or a failure of the module. In particular, the greatest possible care should be taken to prevent any module from being operated where condensation has occurred inside.
5. This panel has its circuitry FPC on the bottom side and should be handled carefully in order not to be stressed.