

MAX38802/MAX38803

Integrated, Step-Down Switching Regulators with Selectable Applications Configurations

General Description

The MAX38802/MAX38803 are fully-integrated, highly efficient switching regulators for applications operating from 6.5V to 14V input supplies that require up to 25A maximum load. These single-chip regulators provide a compact high-efficiency, power-delivery solution for precision outputs that demand fast transient response.

The two devices have different programmability options (see [Tables 3a](#) and [3b](#) for details) to enable a wide range of configurations. The programmable features include: internal/external reference voltage, output voltage set-point, switching frequency, overcurrent protection level (OCP), and soft-start timing. Discontinuous current mode (DCM) operation can be enabled through pin-strapping to improve light-load efficiency.

The MAX38802/MAX38803 include multiple protection and measurement features. Positive and negative cycle-by-cycle OCP, short-circuit protection and overtemperature protection (OTP) ensure robust design. Input undervoltage and overvoltage lockout shut down the regulator to prevent damage when the input voltage is out of specification. Regulation is halted in case of an output overvoltage (OVP) event. A status pin indicates that the output voltage is within range and the output voltage is in regulation. The device has an analog output that can be configured to report output current or junction temperature with $\pm 5\%$ and $\pm 8^\circ\text{C}$ accuracy, respectively.

The devices are available in a 27-bump (2.2mm x 3.8mm) WLCSP package that provides low thermal resistance and minimizes the PCB area.

Applications

- Servers/ μ Servers
- I/O and Chipset Supplies
- GPU Core Supply
- DDR Memory: V_{DDQ} , V_{PP} and V_{TT}
- Point-of-Load (PoL) Applications

DEVICE TYPE	CURRENT RATING	INPUT VOLTAGE	OUTPUT VOLTAGE
MAX38802	25A	6.5V to 14V	0.6V to 5.5V
MAX38803			

Ordering Information appears at end of data sheet.

Quick-PWM is a trademark of Maxim Integrated Products, Inc.

Features and Benefits

- High-Efficiency Solution
 - Up to 97% Peak
 - Up to 87% Full-Load
 - Up to 96% Light-Load Efficiency at 1A with DCM Enabled
- Flexible Design Allows Early PCB Definition
 - Footprint Compatible with MAX38800 (9A) and MAX38801 (15A)
 - Programmable Switching Frequency Up to 1MHz
 - Programmable Soft-Start and STAT Delay Timings
 - Programmable Reference Voltage with External Input Option
 - Programmable Positive and Negative OCP Limit
- Advanced Architecture, Protection and Reporting Guarantees Reliable Designs
 - Analog Current or Temperature Reporting
 - Differential Remote Sense with Open-Circuit Detection
 - Fast Transient Response with Quick-PWM™ Architecture
 - Percentage-Based Output Power Good and OVP
 - Open-Drain Status Indicator (STAT) Pin
 - Input Undervoltage and Overvoltage Lockout
 - Adaptive Dead Time Control
- Saves Board Space
 - Integrated Boost Switch
 - 27-Bump WLCSP (2.2mm x 3.8mm) Footprint
 - Operation Using Ceramic Input and Output Capacitors

Basic Application Circuit

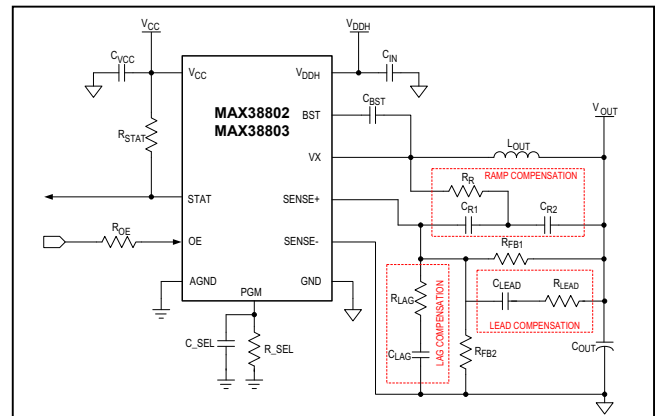

Absolute Maximum Rating

Input/Output Pin Voltages (OE, PGM, SENSE+, SENSE-).....	-0.3V to +2V	V _{DDH} Pin - VX Pin Differential 25ns (Note 2).....	-10V to +23V
Regulator Status Output (STAT).....	-0.3V to +4V	BST Pin (BST) DC.....	-0.3V to 20V
Input Voltage (V _{DDH}) DC.....	-0.3V to +16V	BST Pin (BST) 25ns.....	-7.0V to 27V
Bias Supply Voltage (V _{CC}).....	-0.3V to +2V	BST Pin - VX Pin Differential.....	4V
Switching Node Voltage (VX) DC.....	-0.3V to +16V	Junction Temperature (T _J).....	150°C
Switching Node Voltage (VX) 25ns (Note 1).....	-10V to +23V	Storage Temperature Range.....	-65°C to 150°C
		Peak Reflow Temperature Lead-Free.....	260°C

Stresses beyond those listed under "Absolute Maximum Ratings" may cause permanent damage to the device. These are stress ratings only, and functional operation of the device at these or any other conditions beyond those indicated in the operational sections of the specifications is not implied. Exposure to absolute maximum rating conditions for extended periods may affect device reliability.

Operating Ratings

Input Voltage (V _{DDH}).....	6.5V to 14V	Junction Temperature (T _J).....	0°C to 125°C
Bias-Supply Voltage (V _{CC}).....	1.71V to 1.89V	Peak Output Current (I _{PK+,MAX}).....	40A
Output Current (I _{OUT}).....	25A		

Package Information

27-Bump WLCSP

Package Code	C272C3+1
Outline Number	21-0928
Land Pattern Number	Refer to Application Note 1891
THERMAL RESISTANCE, FOUR-LAYER BOARD	
Junction to Ambient (θ _{JA})	19°C/W (Note 3)
Junction to Case (θ _{JC})	0.75°C/W

For the latest package outline information and land patterns (footprints), go to www.maximintegrated.com/packages. Note that a "+", "#", or "-" in the package code indicates RoHS status only. Package drawings may show a different suffix character, but the drawing pertains to the package regardless of RoHS status.

Package thermal resistances were obtained using the method described in JEDEC specification JESD51-7, using a four-layer board. For detailed information on package thermal considerations, refer to www.maximintegrated.com/thermal-tutorial.

- Note 1:** The 25ns rating is the allowable voltage on the VX node in excess of the -0.3V to 16V DC ratings. The VX voltage can exceed the DC rating in either the positive or negative direction for up to 25ns per cycle.
- Note 2:** The V_{DDH} input pin AC voltage should not exceed 19V (25ns). This measurement is taken at the V_{DDH} pin referenced to V_{SS} pin immediately adjacent using a high-frequency scope probe with I_{LOAD} at I_{MAX}. A high-frequency input bypass capacitor must be located less than 60 mils from the V_{DDH} pin as specified in the [Printed Circuit Board Layout](#) section.
- Note 3:** Data taken using Maxim's evaluation kit with no air flow and no heatsink.

Electrical Characteristics

($V_{CC} = 1.8V \pm 5\%$, unless otherwise specified.)

PARAMETER	SYMBOL	CONDITIONS	MIN	TYP	MAX	UNITS
SUPPLY VOLTAGES, SUPPLY CURRENT, TEMPERATURE RANGE						
12V Supply Voltage Range	V_{DDH}	Note 7	6.5		14	V
1.8V Supply Voltage Range	V_{CC}	Note 7	1.71	1.8	1.89	V
V_{CC} Supply Current	I_{CC}	CCM (Note 7)			35	mA
		DCM (Note 7)			25	
		Shutdown (Note 7)		32	132	μ A
V_{REF}						
Programmable Reference Voltage	V_{REF}	(See Table 3) (Note 8)		0.6		V
V_{REF} Tolerance (V_{REF_TOL})		$T = 35^{\circ}C$ (Note 4)	-0.5		+0.5	
V_{REF} Tolerance Temperature Coefficient ($V_{REF_T_COEFF}$)		$0^{\circ}C < T_J < 100^{\circ}C$ (Note 4)				0.0106
FEEDBACK LOOP						
R_{SENSE} GAIN	Gain	(See Table 3a) (Note 8)		1.4		mV/A
				2.8		
				5.4		
SWITCHING FREQUENCY						
Switching Frequency Accuracy	f_{SW}	Relative to the nominal value (see Figure 4). $0A < I_{LOAD} < Full\ Load\ V_{CC}$, $V_{DDH} \pm 10\%$ (Note 7)	-20		+20	%
Low f_{SW} Threshold		DCM enabled		30		kHz
Forced Minimum f_{SW}		DCM enabled. The low f_{SW} threshold has been crossed.		60		kHz
INPUT PROTECTION						
Rising V_{DDH} UVLO Threshold	V_{DDH} UVLO	Note 7	5.8	6.2	6.5	V
Falling V_{DDH} UVLO Threshold			5.1	5.5	5.9	V
Hysteresis				650		mV
Rising V_{DDH} OVLO Threshold	V_{DDH} OVLO	Note 7	14.3	14.8	15.3	V
Falling V_{DDH} OVLO Threshold			13.8	14.4	14.8	V
Hysteresis				470		mV
Rising V_{CC} UVLO Threshold	V_{CC} UVLO	Note 7	1.49	1.62	1.70	V
Falling V_{CC} UVLO Threshold			1.46	1.57	1.65	V
Hysteresis				50		mV
Rising UVLO Threshold	V_{BST} UVLO	Note 7	1.48	1.57	1.70	V
Falling UVLO Threshold			1.33	1.52	1.65	V
Hysteresis				50		mV

Electrical Characteristics (continued) $V_{CC} = 1.8V \pm 5\%$, unless otherwise specified.

PARAMETER	SYMBOL	CONDITIONS	MIN	TYP	MAX	UNITS
OUTPUT VOLTAGE PROTECTION (OVP)						
Overvoltage-Protection Rising Threshold	OVP	Relative to programmed V_{OUT} (Note 7)	9.5	13	16.5	%
Overvoltage-Protection Deglitch Filter Time			25	30	36	μs
Power Good Protection Falling Threshold	PWRGD	Relative to programmed V_{OUT} (Note 7)	4.5	9	12	%
Power Good Protection Rising Threshold		Note 7	3	6	9	%
Power Good Deglitch Filter Time			25	30	36	μs
OVERCURRENT PROTECTION (OCP)						
Positive Overcurrent-Protection Threshold	OCP	Absolute value of inductor valley current (Note 8)	16		A	
			20			
			24			
Negative Overcurrent-Protection Threshold		Absolute value of inductor valley current (Note 8)	-16		A	
			-20			
			-24			
Overcurrent-Protection Threshold Tolerance		Referenced to nominal value (Note 7)	-20		20	%
Hysteresis (Note 5)		Referenced to inception value (Note 7)	12	15	18	%
OVERTEMPERATURE PROTECTION (OTP)						
Overtemperature-Protection Inception Threshold	OTP	Note 7	130	140	150	$^{\circ}C$
Hysteresis			-30		-10	$^{\circ}C$
TEMPERATURE REPORTING						
Temperature-Reporting Range	T_J		0		125	$^{\circ}C$
Temperature-Reporting Tolerance		Note 7	-4		4	$^{\circ}C$
CURRENT REPORTING						
Current-Reporting Range	I_{LOAD}		0		25	A
Current-Reporting Tolerance		From no load to full load (Note 7)	-2		2	A
		Full Load (Note 7)	-8		8	%

Electrical Characteristics (continued) $V_{CC} = 1.8V \pm 5\%$, unless otherwise specified.

PARAMETER	SYMBOL	CONDITIONS	MIN	TYP	MAX	UNITS
OE PIN						
Input Range	–	Note 7	0		1.89	V
Rising Threshold	$V_{OE(H)}$	Full V_{CC} supply range. Measured at OE Pin (Note 7)	0.89	1.09	1.3	V
Falling Threshold	$V_{OE(L)}$		0.44	0.65	0.83	V
Hysteresis		Note 7	0.34	0.44	0.61	V
Deglintch Filter Time	–		230		520	ns
OE Pin Input Resistance		$UVLO < V_{CC} < OVLO$ (Note 7)	250	435	490	k Ω
STARTUP TIMING						
Enable Time from OE Rise to Start of Regulation	t_{EN}		200	300	500	μ s
Soft-Start Ramp Time	t_{SS}	(See Table 3a) (Note 8)	1.5			ms
			3			
			6			
Dwell Time at V_{OUT} (DCM Not Allowed)	t_{SETTLE}		14		35	μ s
Timing to Charge Boost Capacitor	t_{BST}			8		μ s
STAT PIN						
Pullup Voltage	V_{OHSTAT}				3.6	V
Status Output Low	V_{OLSTAT}	$I_{STAT} = 4mA$ (Note 7)			0.4	V
		$I_{STAT} = 0.2mA$, $0V < V_{CC} < UVLO$ and $0V < V_{DDH} < UVLO$ (Note 7)			0.67	
		$I_{STAT} = 1.3mA$, $0V < V_{CC} < UVLO$ and $0V < V_{DDH} < UVLO$ (Note 7)			0.76	
Current Sinking Capability		$V_{STAT} = 0.4V$ (Note 7)	15	25		mA
Status Output High Leakage Current	I_{STAT}	STAT pull to 3.3V through 20k Ω (Note 7)			7	μ A
Time from V_{OUT} Ramp Completion to STAT Pin Released	t_{STAT}	STAT output low to high (See Table 3) (Note 8)	128			μ s
			2000			
Fault Clearing		Bad-to-good delay	1.8	2	2.2	ms

Electrical Characteristics (continued) $V_{CC} = 1.8V \pm 5\%$, unless otherwise specified.

PARAMETER	SYMBOL	CONDITIONS	MIN	TYP	MAX	UNITS
PGM PIN						
Reporting Voltage Range	V_{PGM}	System regulating	0.5		1	V
Resistor Range	R_{SEL}	Twelve options	1.78		162	k Ω
Resistor Accuracy		EIA standard resistor values only	-1		1	%
Capacitor Range	C_{SEL}	Three options	0		820	pF
C_{SEL} Capacitor Accuracy			-20		20	%
External Capacitance		Load and stray capacitance in addition to C_{SEL}			20	pF
SYSTEM SPECIFICATIONS (Note 6)						
Peak-to-Peak Output Ripple Voltage, DCM Disabled	$V_{OUT-RIPL}$		-1		1	%
Peak-to-Peak Input Ripple Voltage	$V_{IN-RIPL}$	$V_{DDH} = 10.8V - 13.2V$	-1		1	%
Line Regulation	V_{OUT}	$V_{DDH} = 10.8V - 13.2V$			0.15	%
Load Regulation (Static)		$I_{OUT} = 0A - I_{MAX}$	-0.5		0.5	%
Load Regulation (Dynamic)		$V_{DDH} = 10.8V - 13.2V$, I_{OUT} step 6A at 36A/ μ s, 1kHz - 1MHz repetition rate, 10% - 90% duty cycle	-3		+3	%

Note 4: To calculate the total V_{REF} tolerance over a temperature variation of ΔT :

$$V_{REF_TOL_TOT} = V_{REF_TOL} + |\Delta T| \times V_{REF_T_COEFF}$$

Note 5: The OCP hysteresis is for positive current OCP only, negative current OCP hysteresis is always 0.**Note 6:** Tested using circuit of the [Typical Application Circuit – 2.5V, 12A \(MAX38802\)](#) with $C_{OUT} = (5 \times 22\mu F) + (4 \times 47\mu F)$. $V_{OUT} = 2.5V$.**Note 7:** Denotes specifications that apply over the temperature range of $T_J = 0^\circ C$ to $+125^\circ C$. Otherwise, specifications are for $T_J = +25^\circ C$.**Note 8:** Denotes parameters that are programmable.

Typical Operating Characteristics

($V_{DDH} = 12V$, $V_{CC} = 1.8V$. Curve indicates $T_{CASE} = 125^{\circ}C$ or $I_{OUT} = I_{MAX}$, whichever happens first.)

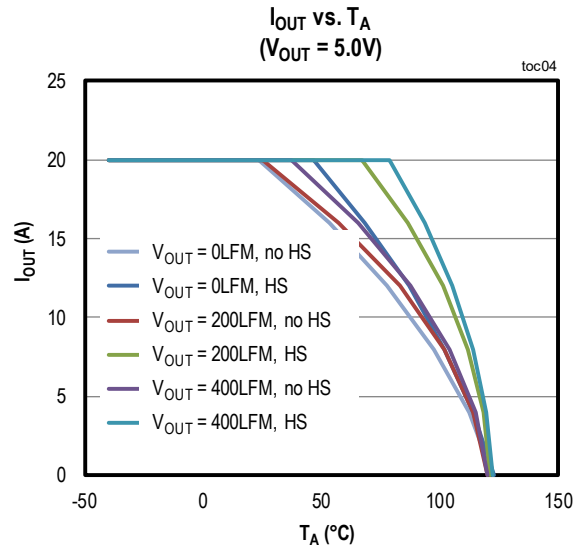
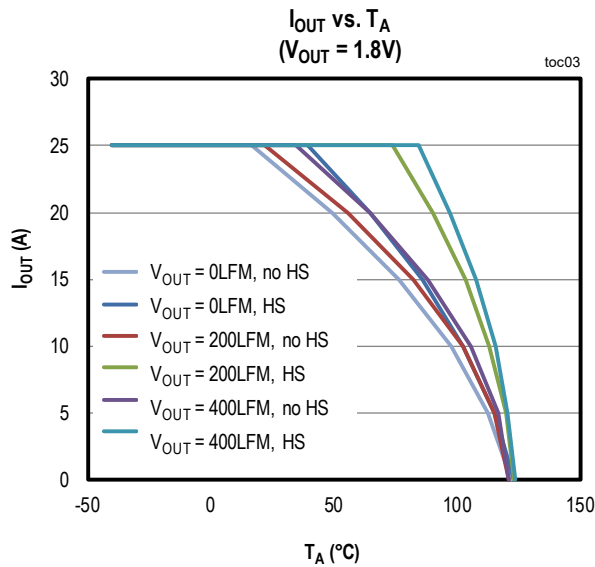
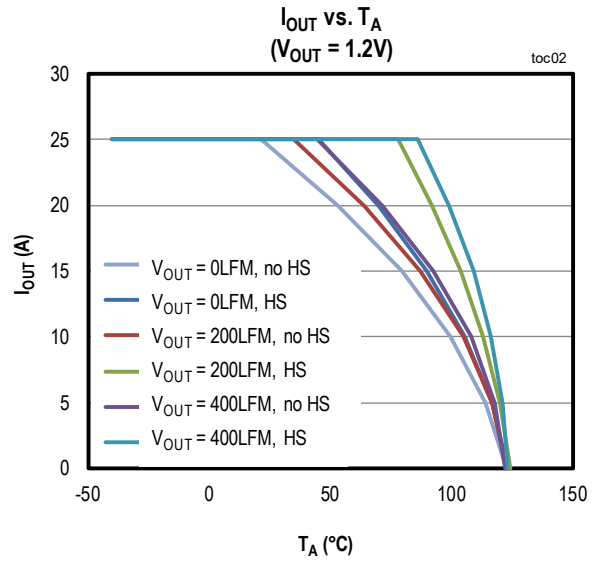
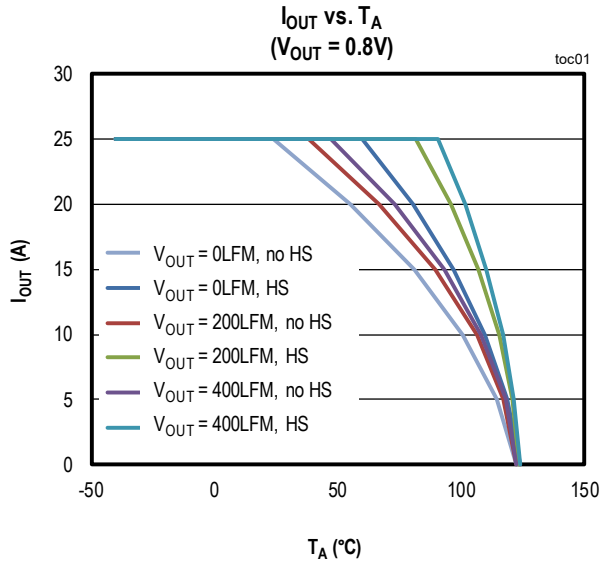

Typical Operating Characteristics (continued)

($V_{DDH} = 12V$, $V_{CC} = 1.8V$. Curve indicates $T_{CASE} = 125^{\circ}C$ or $I_{OUT} = I_{MAX}$, whichever happens first.)

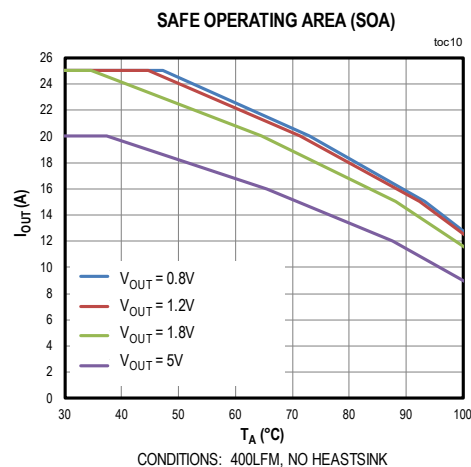
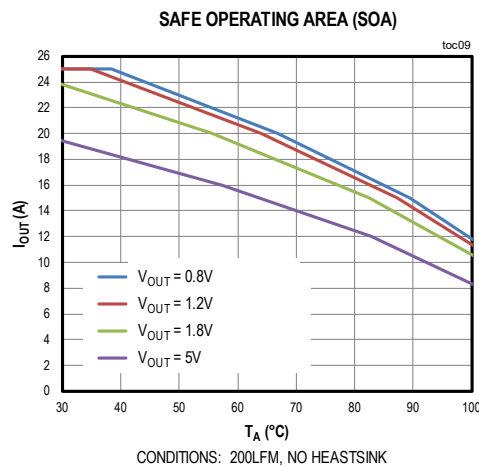
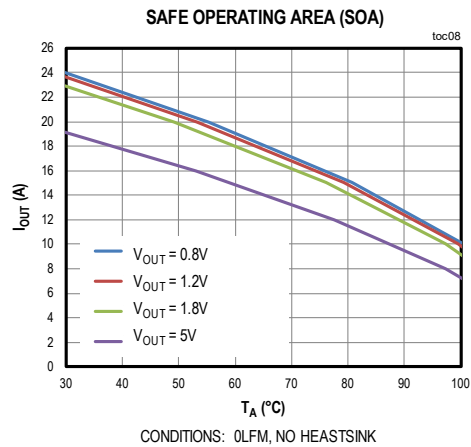
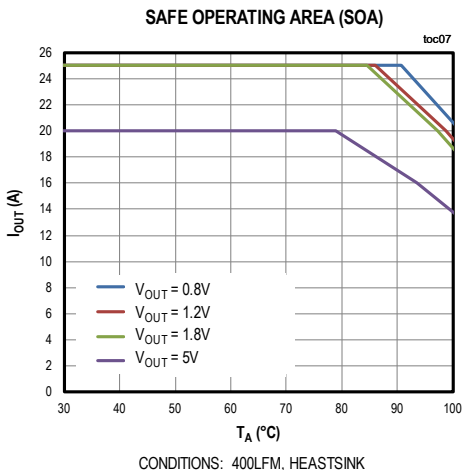
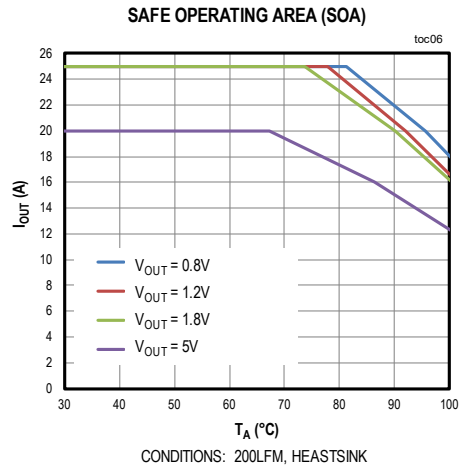
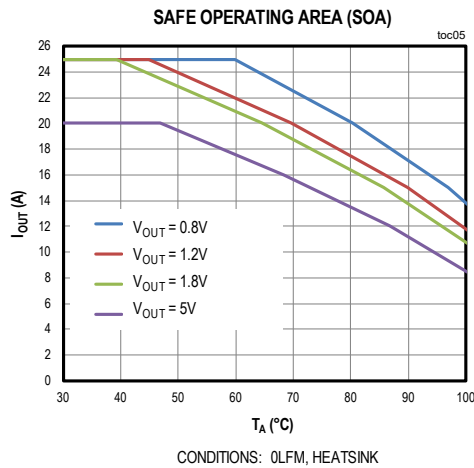

Typical Operating Characteristics (continued)

($V_{DDH} = 12V$, $V_{CC} = 1.8V$, f_{sw} Setting #6, $C_{OUT} = 5 \times 22\mu F + 4 \times 47\mu F$, $L_{OUT} = 680nH$ for $V_{OUT} \geq 2.5V$, $L_{OUT} = 200nH$ for $V_{OUT} \leq 1.8V$)

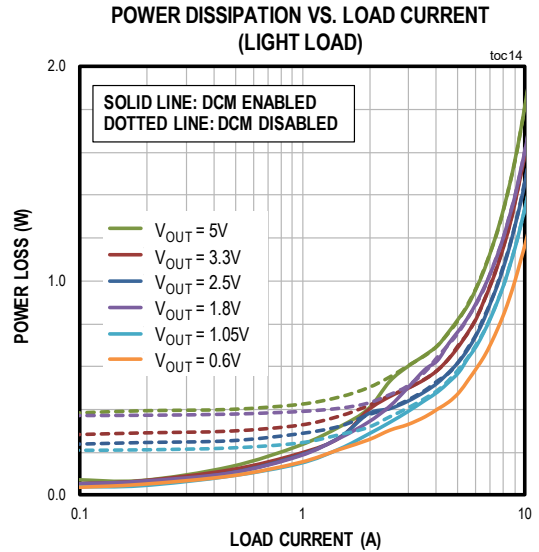
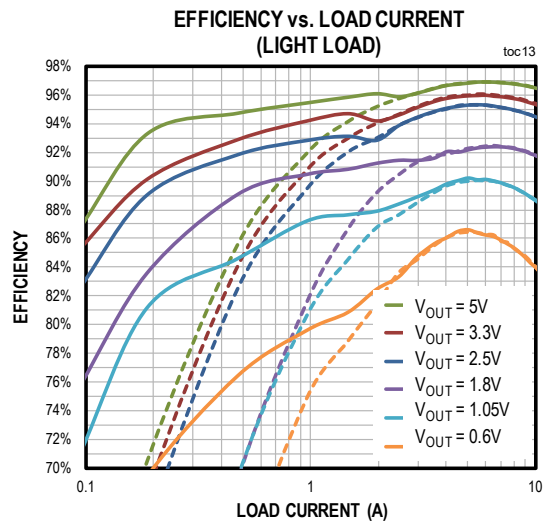
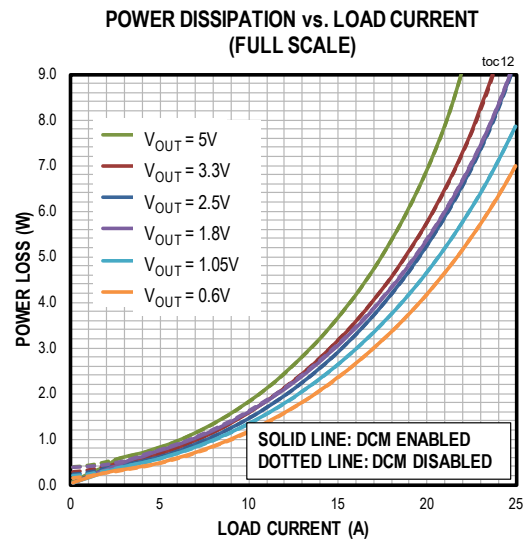
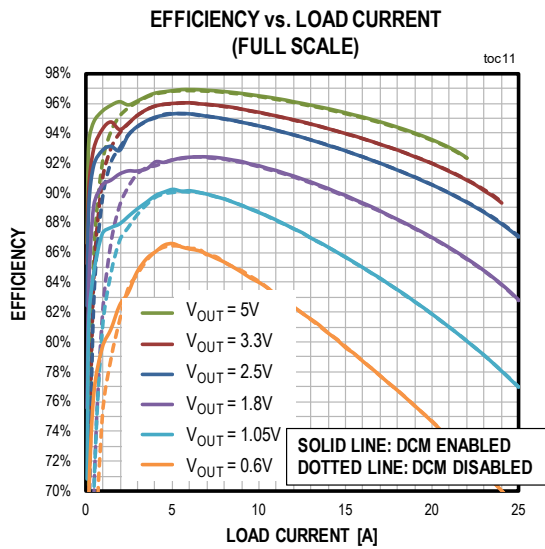

Typical Operating Characteristics (continued)

($V_{DDH} = 12V$, $V_{CC} = 1.8V$, $V_{OUT} = 2.5V$, Circuit of Figure 1, $R_{SEL} = 6.04k\Omega$, $R_{FB1} = 4.32k\Omega$, $R_{FB2} = 2.61k\Omega$, No heatsink, $I_{LOAD} = 15A$, unless otherwise noted.)

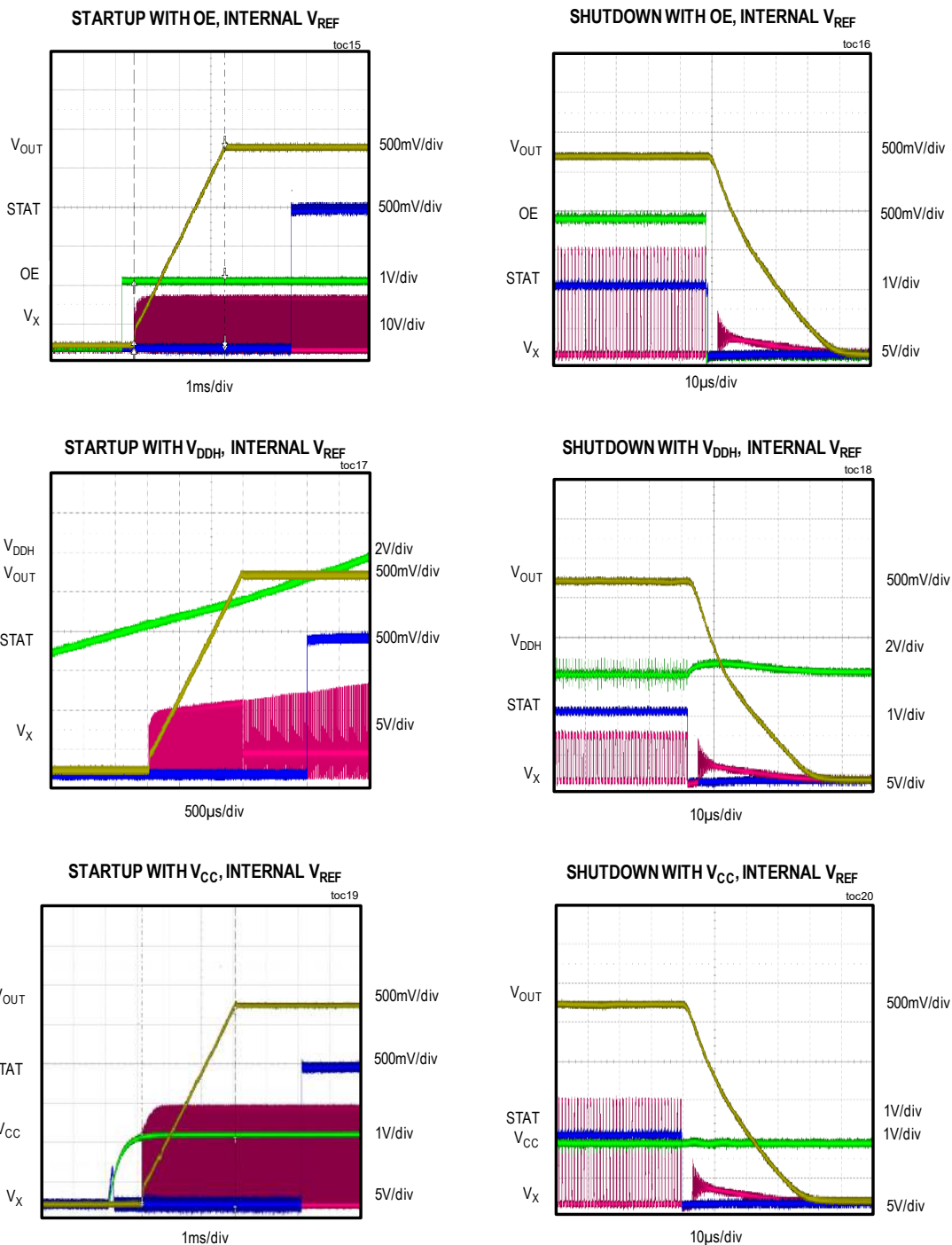

Typical Operating Characteristics (continued)

($V_{DDH} = 12V$, $V_{CC} = 1.8V$, $V_{OUT} = 2.5V$, Circuit of Figure 9, $R_{SEL} = 9.09k\Omega$, $R_{FB1} = 4.32k\Omega$, $R_{FB2} = 2.61k\Omega$, External $V_{REF} = 0.95V$. No heatsink, unless otherwise noted.)

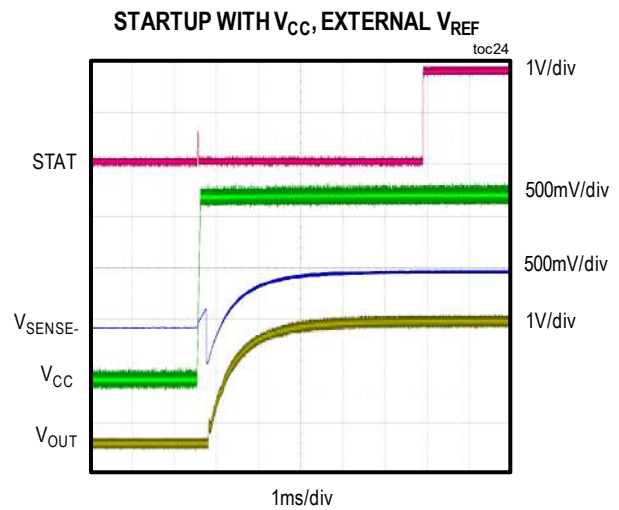
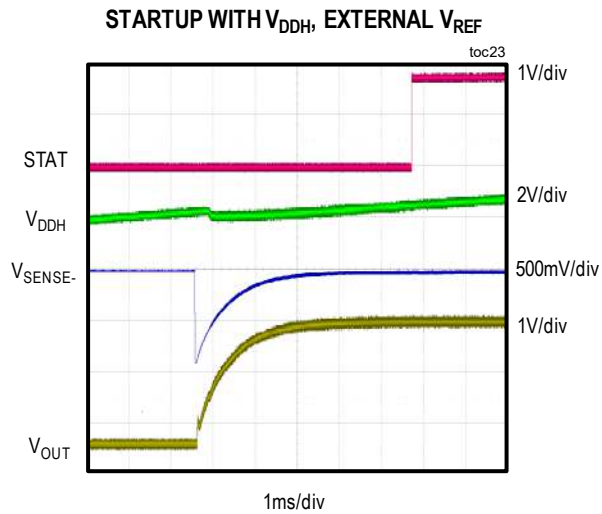
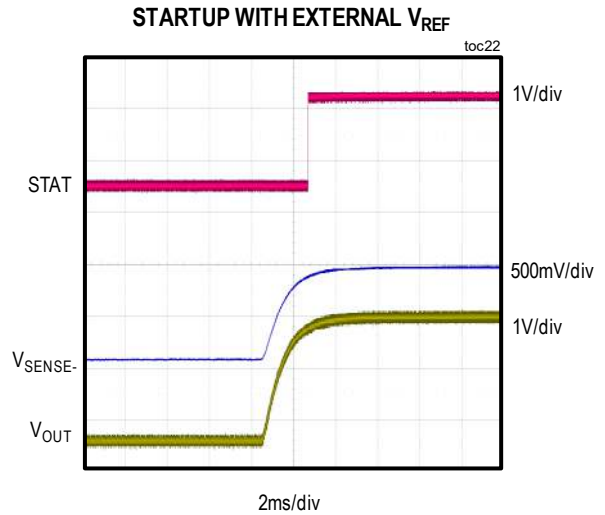
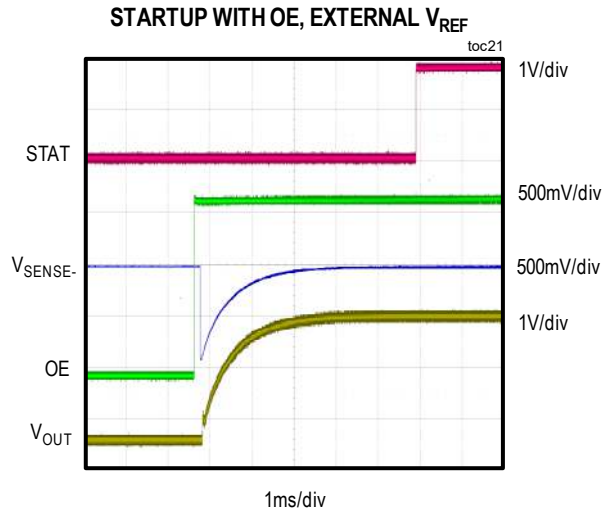

Typical Operating Characteristics (continued)

($V_{DDH} = 12V$, $V_{CC} = 1.8V$, $V_{OUT} = 2.5V$, Circuit of [Figure 1](#), $C_{OUT} = 5 \times 22\mu F + 4 \times 47\mu F$, $L = 680nH$, f_{sw} Setting #6, Load Step = 6A at 36A/ μs .)

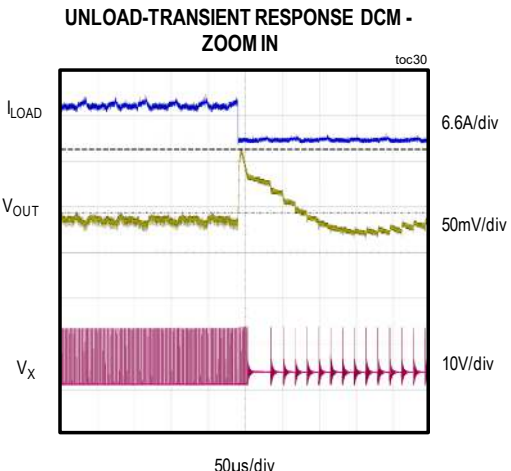
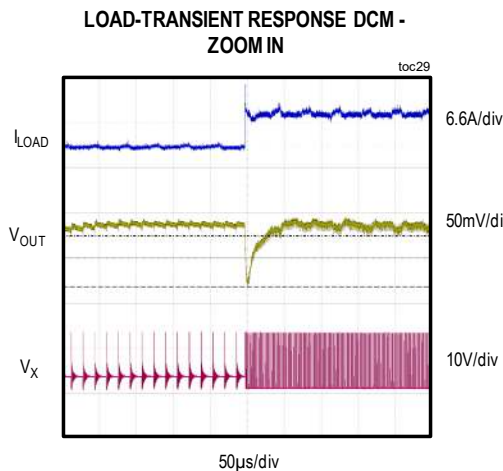
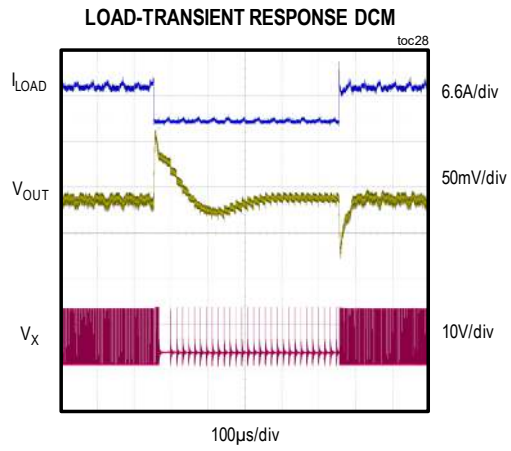
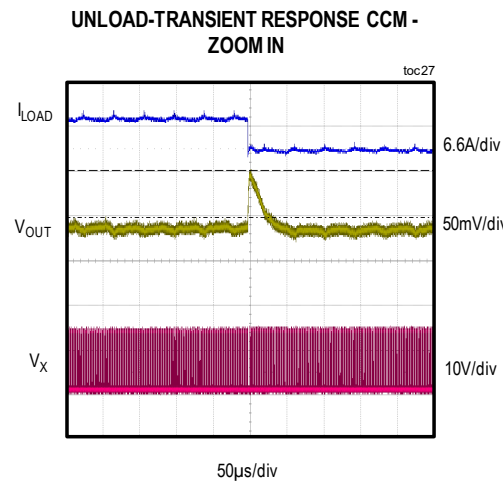
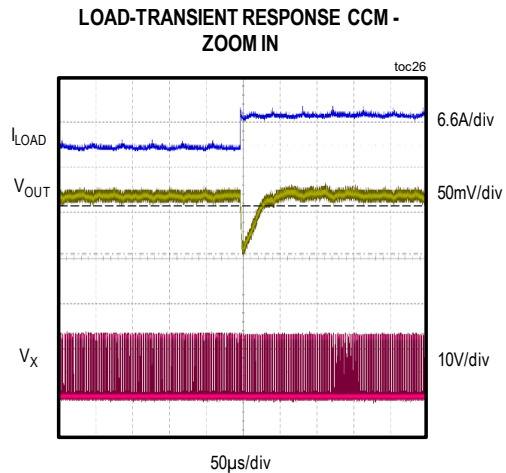
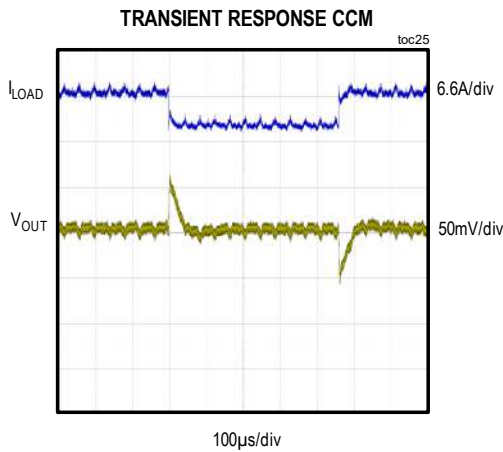

Typical Operating Characteristics (continued)

($V_{DDH} = 12V$, $V_{CC} = 1.8V$, $V_{OUT} = 2.5V$, Circuit of [Figure 1](#), $C_{OUT} = 5 \times 22\mu F + 4 \times 47\mu F$, $L = 680nH$, f_{SW} Setting #6, $OCP = 16A$.
No heatsink, unless otherwise noted.)

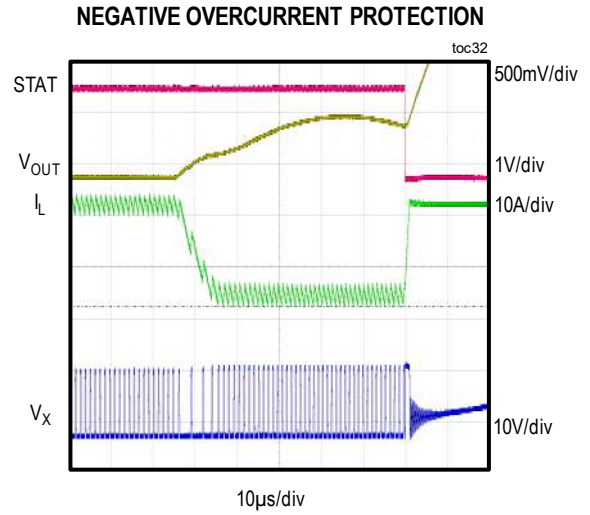
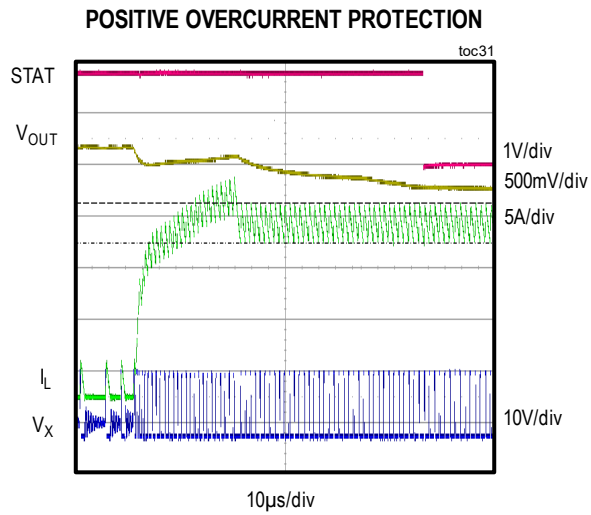

Pin Description

PIN	NAME	FUNCTION
A1	SENSE-	Negative Remote-Sense/External-Reference Input. Connect the SENSE- pin to ground at the load with a Kelvin connection to use the internal voltage reference, or connect the pin to an external reference voltage as shown in Figure 6 .
A2	AGND	Analog/Signal Ground. Connect to ground plane following the recommendations mentioned in the Printed Circuit Board Layout section.
A4	STAT	Open-Drain Status Output. This pin is pulled low to indicate a fault or output-undervoltage and output-overvoltage events.
B1	PGM	Programming Input/Telemetry Output. Connect PGM to analog ground using a programming resistor and capacitor. The resistance and capacitance values are measured at startup to determine the desired regulator settings (see Table 3a and Table 3b). Refer to the <i>Current/Temperature Reporting and Programming Options</i> sections for more information.
B2	SENSE+	Positive Remote-Sense Input. Connect SENSE+ to V_{OUT} at the load using a Kelvin connection. A resistive voltage-divider can be inserted between the output and SENSE+ to regulate the output above the reference voltage.
B3	OE	Output-Enable Input. Connect to enable signal through a 20k Ω resistor. When OE is low, the VX node is high-impedance. Toggle OE to clear the fault-protection latch.
B4	V _{CC}	Supply-Voltage Input. Use this pin for the regulator's analog, digital and gate drive circuits. Connect V _{CC} to 1.8V and closely bypass the pin to power ground with a 1 μ F or greater ceramic capacitor.
C1–C3	V _{DDH}	Power-Input Voltage. Connect V _{DDH} to the input power supply source. High-frequency ceramic decoupling capacitors must be placed in close proximity to the pin. Refer to Table 4 for decoupling recommendations.
C4	BST	Bootstrap Supply Input. Connect a 0.47 μ F ceramic capacitor in close proximity to the IC between BST and VX, as specified in Table 4 and the Printed Circuit Board Layout section.
D1–D4, F1–F4	VX	Switching Node. Connect to the switching node of the power inductor.
E1–E4, G1–G4	GND	Power Ground. Connect to the return path of the output load.

Block Diagram

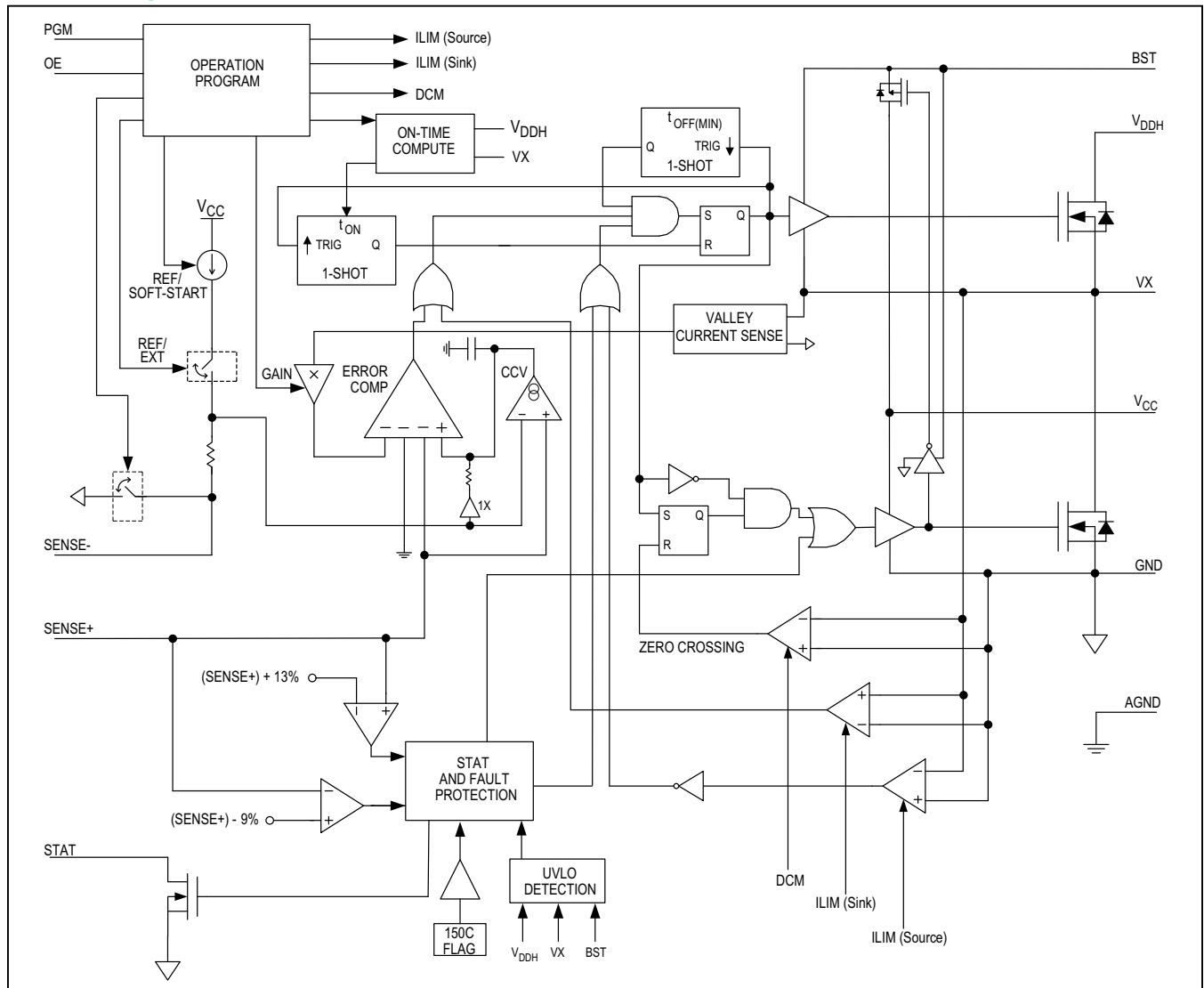

Detailed Description

Control Architecture

The MAX38802/MAX38803 step-down regulators are ideal for low-duty cycle (high-input voltage to low-output voltage) applications. Maxim’s proprietary Quick-PWM pulse-width modulator in the MAX38802/MAX38803 is a pseudo-fixed frequency, constant on-time, current-mode regulator with voltage feed-forward (*Block Diagram*). The architecture is specifically designed for handling fast load steps while maintaining a relatively constant operating frequency and inductor operating point over a wide range of input volt-

ages. This approach circumvents the poor load-transient timing problems of fixed-frequency, current-mode PWMs while also avoiding the problems caused by widely varying switching frequencies in conventional constant-on-time pulse-frequency modulation control schemes, regardless of input voltage.

Traditional constant on-time architectures require an output capacitor with a specified minimum ESR to ensure stable operation. This restriction does not apply to the MAX38802/MAX38803 because the inductor valley current is added to the feedback signal using a proprietary current-sense method, which improves stability.

The control algorithm is simple: the high-side switch on-time is determined solely by a one-shot whose pulse width is inversely proportional to input voltage and directly proportional to output voltage (Equation 1). Another one-shot sets a minimum off-time of 100ns (typ).

Under normal operating conditions, the on-time one-shot is triggered if the sum of the feedback voltage and the valley current-sense signal falls below the control voltage, and the minimum off-time one-shot has timed out. The t_{ON} pulse width is clamped to a maximum of 2.5 μ s.

Equation 1

$$t_{ON} = \frac{V_{X_{AVE}}}{f_{SW} \times V_{DDH}}$$

where:

- f_{SW} = Switching frequency (MHz)
- t_{ON} = On-time period for high-side switch (μ s)
- $V_{X_{AVE}}$ = Average VX voltage (V)
- V_{DDH} = Input voltage (V)

Voltage Regulator Enable and Turn-On Sequencing

The startup sequence is shown in [Figure 1](#). Once the OE pin rises above the $V_{OE(H)}$ threshold, the control circuits wait for a 300 μ s t_{EN} time to allow the bias circuits, analog blocks, and other circuits to settle to their proper states before beginning the regulation.

The OE pin has a voltage rating of 1.8V. For control signal voltages higher than 1.8V, a resistor-divider network must be used to drive the OE pin.

In addition, the impedance of the OE pin is reduced when the V_{CC} is below UVLO. To prevent any damage to the part due to lowering the impedance, a resistor is used to limit the current. For 1.8V control signals, this resistor has a value of 20k Ω and it is placed in series with the OE pin. For higher drive voltages to OE that require a resistive voltage-divider, choose 20k Ω for the bottom resistor to ground. The top resistor is given by Equation 2. Use closest higher resistor value available.

Equation 2

$$R_{TOP} = 20k\Omega \times \left[\left(\frac{V_{SIG}}{1.8V} \right) - 1 \right]$$

Output enable delay timing can be added using an RC network connected between control signal and OE pin. R-C delay networks are designed based on desired turn on/off timings and the $V_{OE(H)}$ / $V_{OE(L)}$ thresholds.

The OE pin has nominal input impedance, which should be included in calculations for the divider network (see the [Electrical Characteristics](#) table for nominal impedance).

When the system pulls OE low, the MAX38802/MAX38803 enter low-power shutdown mode. STAT is pulled low immediately. The MAX38802/MAX38803 discharge the inductor by keeping the low-side FET enabled until the current reaches zero. Under these conditions, both power FETs are in high-impedance and the regulator enters shutdown.

Soft-Start Control

Once the OE reaches its threshold and the t_{EN} has elapsed, the regulator performs the bootstrap capacitor charging sequence. After bootstrap capacitor is fully charged, the internal reference voltage starts ramping to the target voltage with the appropriate soft-start time (t_{SS}). Both soft-start timing, and target voltage can be programmed (see the [Programming Options](#) section, and [Table 3a](#) and [3b](#)).

If the regulator is enabled with a prebiased output voltage, the system does not regulate until the reference voltage ramps above the SENSE+ node voltage. Upon reaching the SENSE+ voltage, the regulator performs the C_{BST} charging sequence and starts normal operation. If, at the end of t_{SS} , the SENSE+ pin voltage is still higher than the internal reference, continuous conduction mode (CCM) operation is forced for a short period of time (t_{SETTLE}) to discharge the output to the desired voltage. After this period, discontinuous conduction mode (DCM) is allowed, if selected, and the OVP/UVLP circuitry becomes active.

Remote Output Voltage Sensing

Remote output-voltage sensing is implemented to improve output-voltage regulation accuracy at the load. This technique reduces errors due to voltage drops in the plane impedance between the load and the MAX38802/MAX38803, particularly in cases where the load is placed away from the MAX38802/MAX38803. Remote output-voltage sensing is implemented by using the SENSE-node as a reference for the internal voltage reference V_{REF} .

Switching Operation Modes

The MAX38802/MAX38803 support both CCM and DCM. The mode of operation can be programmed as indicated in the [Programming Options](#) section, and [Table 3a](#) and [3b](#).

If DCM is enabled, MAX38802/MAX38802A transition seamlessly to DCM at light loads to improve efficiency. Once in DCM, the switching frequency decreases as load decreases until a minimum frequency of 30kHz is reached. The purpose of this minimum switching frequency limitation is to prevent operation in the audible frequency range to reduce audible noise.

If the load is such that no t_{ON} pulse is generated for $\sim 33\mu s$ (1/30kHz) since the last pulse was issued, the low-side FET is turned ON until the error comparator commutates, and a t_{ON} pulse is issued. Once this minimum frequency mode is entered, the IC operates with a minimum switching frequency of 60kHz, to provide proper hysteresis and prevent the IC from moving in and out of this mode.

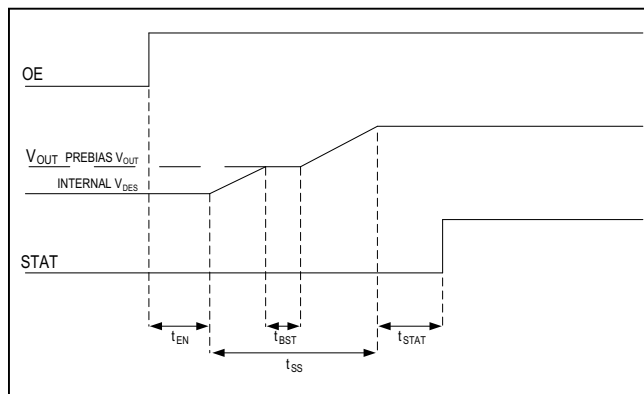

Figure 1. Startup Timing

Protection And Status Features

Output Voltage Protection (OVP)

The SENSE+ pin is continuously monitored for both undervoltage and overvoltage conditions. If the output voltage falls below the PWRGD threshold (9% of programmed output voltage) for more than 30 μs (typ), the STAT pin is driven low while the MAX38802/MAX38803 continue to operate, attempting to maintain regulation. If the output voltage rises above the overvoltage protection threshold (13% of programmed output voltage) for more than 30 μs (typ), the STAT pin is driven low and the MAX38802/MAX38803 latch off (high-side and low-side FETs turn off). Toggle OE or cycling V_{CC} supply is required to clear fault conditions.

Current Limiting

The MAX38802/MAX38803 have a current limit that can be programmed using the appropriate R_SEL value (see [Table 3a](#) and [3b](#)). The overcurrent protection (OCP) monitors and limits the low-side FET current on a cycle-by-cycle basis. If the minimum instantaneous “valley” low-side switch current level exceeds the OCP (source) level, the IC delays the next on-time pulse until the current falls below the threshold level ([Figure 2](#)). Since the regulator responds to the inductor valley current, the DC current delivered during positive (source) current limit is the programmed valley current (I_{OCP} - hysteresis) plus half of the inductor ripple. During the current limit event (source), the output voltage drops and if the voltage reaches the PWRGD threshold, the STAT pin is driven low.

The MAX38802/MAX38803 also have negative OCP limits (Sink). When this threshold is reached, the IC

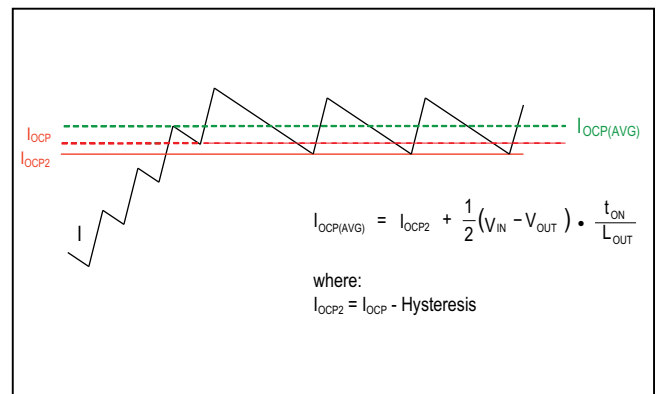

Figure 2. Inductor Current During Current Limit Event

issues an on-time pulse to limit the negative current. This on-time pulse is issued regardless of the error comparator state. Therefore, it is possible to cause an overvoltage protection (OVP) event if the negative load exceeds the negative current limit.

UVLO and OVLO Protection

The regulator monitors V_{DDH} with both undervoltage lockout (UVLO) and overvoltage lockout (OVLO) circuits. UVLO protection is also present on BST and V_{CC} supplies. When any of the supply voltages is below the UVLO threshold or V_{DDH} is above the OVLO threshold, the regulator stops switching, and the STAT pin is driven low (refer to the [Electrical Characteristics](#) table for UVLO and OVLO levels).

Overtemperature Protection (OTP)

If the die temperature exceeds the overtemperature threshold during operation, the MAX38802/MAX38803 stop regulation and the STAT pin is driven low. Regulation starts again once the die temperature falls below the new overtemperature threshold (overtemperature threshold - hysteresis) value. The STAT pin eventually goes high again once the output voltage reaches the expected value.

Regulator Status

The regulator status (STAT) signal provides an open-drain output (4V max, refer to the [Absolute Maximum Rating](#) section) that indicates whether the MAX38802/MAX38803 are functioning properly. An external pullup resistor is required.

After the startup ramp is completed (t_{STAT}), if the output voltage is within the PWRGD/OVP regulation window, the STAT pin goes high impedance. The STAT pin is driven low when one or more of the following conditions exist:

- OE is low
- V_{DDH} or V_{CC} are not present or below/above the respective UVLO/OVLO thresholds.

- A PWRGD fault is present (see the [Output Voltage Protection \(OVP\)](#) section).
- The SENSE- or SENSE+ pin is left unconnected at startup.
- The die temperature is above the maximum allowed temperature.
- The OVP circuit has detected that the output voltage is above the tolerance limit.
- UVLO is detected on bootstrap supply (BST-VX), indicating possible short or open bootstrap capacitor.

Current/Temperature Reporting

During regulation, an analog voltage is produced on the PGM pin that represents either average output current or chip temperature (see [Table 3a](#) and [3b](#) for proper settings). The PGM pin has an output-voltage range of 0.5V to 1V. The PGM output is designed to drive the R_SEL/C_SEL network with an additional 20pF external load (including parasitics), which allows this node to be connected to external circuitry, such as a voltage buffer or ADC.

The conversion equations for temperature and current reporting are shown in Equation 3 and Equation 4.

Equation 3

$$T_{REPORTED} = (V_{PGM} - T_{rOFFSET}) \times T_{rSLOPE}$$

$$T_{rOFFSET} = 0.592V$$

$$T_{rSLOPE} = 611 \frac{^{\circ}C}{V}$$

Equation 4

$$I_{REPORTED} = (V_{PGM} - I_{rOFFSET}) \times I_{rSLOPE}$$

$$I_{rOFFSET} = 0.495V$$

$$I_{rSLOPE} = 86.2 \frac{A}{V}$$

Table 1. Summary of Fault Actions

FAULT TYPE	REGULATOR RESPONSE	STAT	DESCRIPTION
Power Good (PWRGD)	Continue Operation	LOW	$V_{OUT} < (1 - 9\%) V_{OUTNOM}$
Overvoltage Protection (OVP)	Shutdown and Latchoff	LOW	$V_{OUT} > (1 + 13\%) V_{OUTNOM}$
Overtemperature Protection (OTP)	Shutdown	LOW	$T_J > 140^{\circ}C$
Overcurrent Protection (OCP)	Clamping	V_{OUT} Drop, LOW	Valley current higher than selected limit
Boost Undervoltage	Shutdown	LOW	$(BST - VX) < 1.52V$
V_{DDH} Supply	Shutdown	LOW	$V_{DDH} < 5.5V$ or $V_{DDH} > 14.8V$
V_{CC} Supply	Shutdown	LOW	$V_{CC} < 1.57V$
SENSE-/SENSE+ Disconnected	Do Not Start	LOW	Open Sense Lines

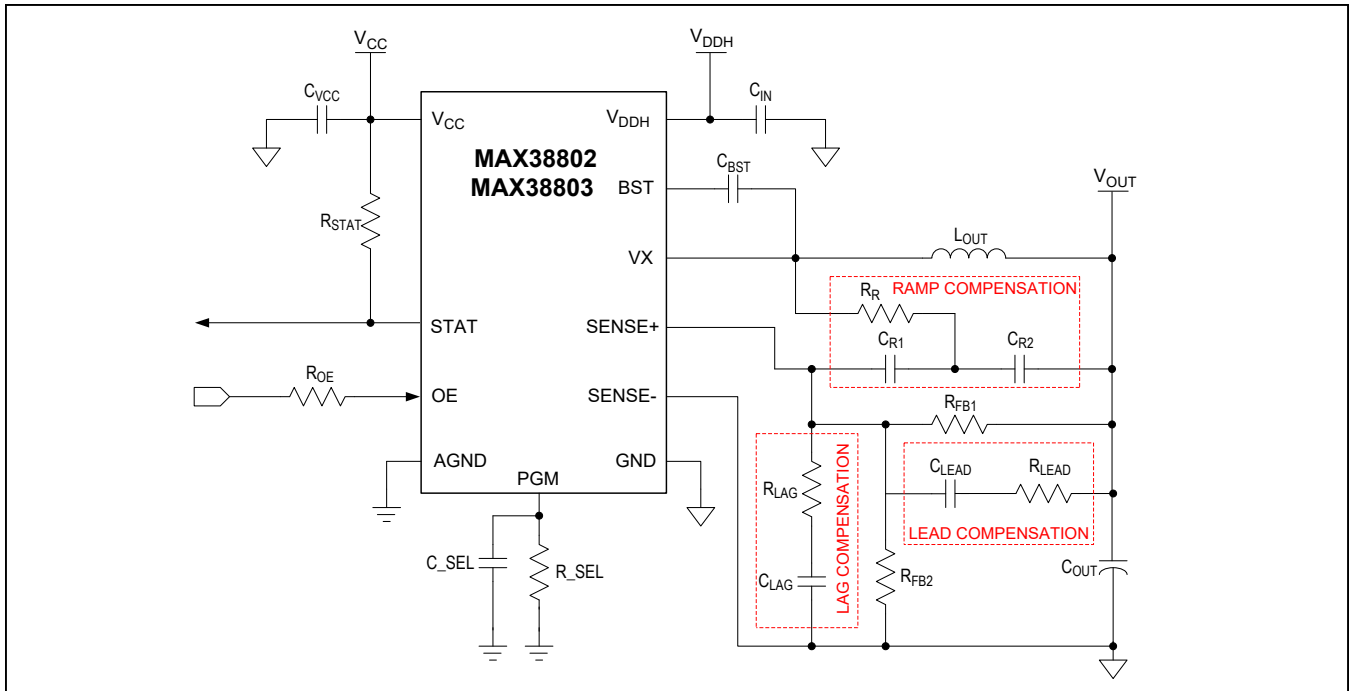

Figure 3. Typical Application Circuit

Reference Design

The typical application circuit is shown in [Figure 3](#).

Programming Options

The MAX38802/MAX38803 allow programming of several key parameters to allow optimization for specific applications. The parameters that are programmable are shown in [Table 2](#). A resistor and capacitor connected from the programming pin to ground select a set of parameters.

By selecting the appropriate values of resistor and capacitor, the desired set of parameters (scenario) can be programmed, as shown in [Table 3a](#) and [3b](#).

C_SEL selects the f_{SW} setting. There are six options available (from #1 to #6), indicating six different nominal switching frequencies, from lowest to highest. Since the actual value of f_{SW} also depends on V_{OUT} , refer to [Figure 4](#) to select the proper f_{SW} setting for a specific application.

The MAX38802/MAX38803 feature two different configuration tables to provide a wider range of options. [Table 3a](#) and [3b](#) show the scenario options for the MAX38802/MAX38803, respectively.

Table 2. Programmable Options

PARAMETER	DESCRIPTION
V_{REF}	Selects internal or external voltage reference. For internal V_{REF} two values are available.
Soft-Start Time	The time required to ramp the reference voltage to its final value
OCP Inception	The valley current at which the overcurrent protection is tripped (see the <i>Current Limiting</i> section).
Operation Modes	Selects whether DCM is allowed. If allowed the IC transitions to DCM mode for light loads
Reporting	Selects the parameter reported through the analog output voltage on the PGM pin during regulation.
R_{SENSE} Gain	Selects the sense loop gain. By changing this value, the operation and components selection can be optimized.
f_{SW}	Switching frequency setting.
t_{STAT}	Time delay between the completion of the soft-start ramp and the STAT pin output is valid.

Table 3a. MAX38802 Configuration Table

R_SEL (kΩ)	V _{REF} (V)	SOFT-START TIME (t _{SS}) (ms)	VALLEY OCP INCEPTION (A)	OPERATION MODES	REPORTING (CURRENT/TEMP)	R _{SENSE} (GAIN) (mΩ)	f _{SW} SETTING			t _{STAT} (μs)
							C_SEL			
							0pF	200pF	820pF	
1.78	0.95	6	16	CCM	Current	2.8	f _{SW} #4	f _{SW} #5	f _{SW} #6	2000
2.67				CCM/DCM						
4.02				CCM						
6.04				CCM/DCM						
9.09	Ext.	1.5	16	CCM	Temp	1.4	f _{SW} #1	f _{SW} #2	f _{SW} #3	128
13.3				CCM						
20	0.6	6	24	CCM/DCM	Temp	1.4	f _{SW} #1	f _{SW} #2	f _{SW} #3	128
30.9				CCM						
46.4			16	CCM/DCM						
71.5				CCM/DCM						
107				CCM/DCM						
162	Ext.	1.5	20	CCM	Temp	1.4	f _{SW} #1	f _{SW} #2	f _{SW} #3	128

Table 3b. MAX38803 Configuration Table

R_SEL (kΩ)	V _{REF} (V)	SOFT-START TIME (t _{SS}) (ms)	VALLEY OCP INCEPTION (A)	OPERATION MODES	REPORTING (CURRENT/TEMP)	R _{SENSE} (GAIN) (mΩ)	f _{SW} SETTING			t _{STAT} (μs)
							C_SEL			
							0pF	200pF	820pF	
1.78	0.95	1.5	16	CCM	Current	2.8	f _{SW} #4	f _{SW} #5	f _{SW} #6	2000
2.67				CCM/DCM						
4.02				CCM						
6.04				CCM/DCM						
9.09	Ext.	3	16	CCM	Temp	5.4	f _{SW} #1	f _{SW} #2	f _{SW} #3	128
13.3				CCM/DCM						
20	0.6	3	24	CCM/DCM	Temp	1.4	f _{SW} #1	f _{SW} #2	f _{SW} #3	128
30.9				CCM						
46.4			16	CCM/DCM						
71.5				CCM/DCM						
107				CCM/DCM						
162	Ext.	1.5	20	CCM	Temp	1.4	f _{SW} #1	f _{SW} #2	f _{SW} #3	128

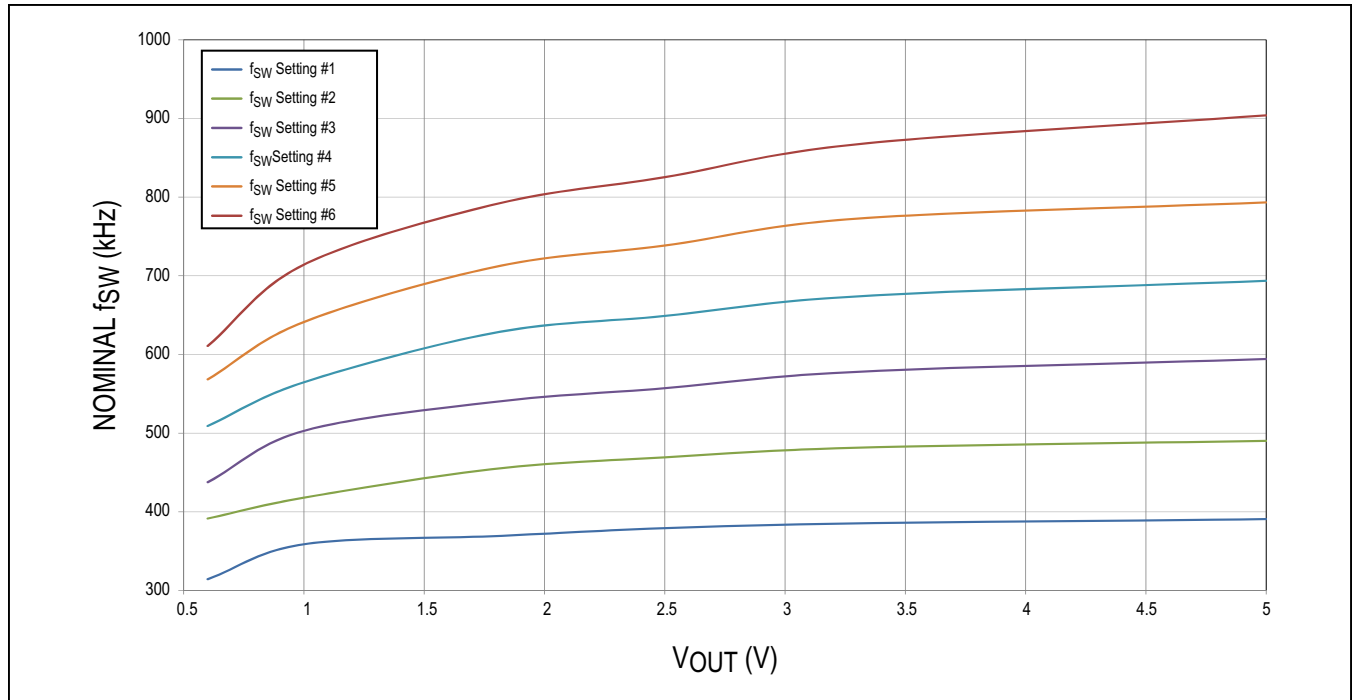

Figure 4. Nominal Switching Frequency vs. V_{OUT} and f_{SW} Setting

Setting the Output Voltage

The output voltage of the MAX38802/MAX38803 is set by selecting a reference voltage and using an appropriate resistive voltage-divider, as shown in Equation 5.

The reference voltage is selected using R_SEL (see Table 3a and 3b) and can be either internal or external (refer to the Operation with External V_{REF} section for more details). In order to improve the DC output voltage accuracy, use the highest V_{REF} value available and suitable for the application.

For instance, use V_{REF} = 0.6V for 0.6V ≤ V_{OUT} < 0.95V and V_{REF} = 0.95V for 0.95V ≤ V_{OUT} < 5.5V.

To optimize the common-mode rejection of the error amplifier, choose the voltage-divider resistors so that their parallel resistance is as close as possible to 2kΩ (Equation 6).

Equation 5

$$V_{OUT} = V_{REF} \times \left(1 + \frac{R_{FB1}}{R_{FB2}} \right)$$

Refer to Table 3a and 3b for V_{REF} values.

Equation 6

$$R_{FB1} = V_{OUT} \times \left(\frac{R_{PAR}}{V_{REF}} \right)$$

$$R_{FB2} = R_{FB1} \times \left(\frac{R_{PAR}}{R_{FB1} - R_{PAR}} \right)$$

where:

- R_{FB1} = Top voltage-divider resistor
- R_{FB2} = Bottom voltage-divider resistor
- R_{PAR} = Desired parallel resistance of R_{FB1} and R_{FB2}
- V_{OUT} = Output voltage
- V_{REF} = Reference voltage

The Effect of Resistor Selection on DC Output Voltage Accuracy

R_{FB1} and R_{FB2} set the output voltage as described in Equation 5. The tolerance of these resistors affects the accuracy of the programmed output voltage.

Equation 7

$$\epsilon_{RV_{OUT}} = \frac{2\epsilon_R}{1 - \epsilon_R} \left(\frac{V_{OUT} - V_{REF}}{V_{OUT}} \right)$$

Figure 5 shows the effect of 1% tolerance resistors over a range of output voltages. To ensure accuracy over temperature, the temperature coefficients must also be included in the error calculation (i.e., for 25ppm/°C resistors over a 50°C excursion, add 0.125% to the 25°C tolerance).

The error due to the voltage-feedback resistors' tolerance, R_{FB1} and R_{FB2} should be added to the output voltage tolerance due to the IC's V_{REF} tolerance listed in the [Electrical Characteristics](#) table.

Equation 8

$$\epsilon_{V_{OUT}} = \epsilon_{V_{REF}} + \epsilon_{RV_{OUT}}$$

Voltage Margining

Voltage margining can be implemented by changing the effective feedback divider ratio. FET switches can be used to introduce or remove parallel resistors to R_{FB2}, to increase or decrease the output voltage respectively. In order to avoid triggering OVP or UVP faults, the circuits used to introduce resistive divider changes should have

switching time constants greater than the response time of the MAX38802/MAX38803.

Operation with External V_{REF}

When using an external reference, adopt the configuration shown in Figure 6. The MAX38802/MAX38803 employ a specialized soft-start sequence. Once OE is asserted, the regulator briefly discharges the SENSE- node and releases it as regulation begins. The resulting soft-start ramp timing is determined by the external low-pass filter time constant. The external filter time constant needs to be lower than t_{SS}/3 in order to avoid premature assertion of the STAT pin while the output voltage is still ramping.

The external reference voltage can be applied prior to enabling the regulator, or ramped up right after enable is asserted. In both cases, the low-pass filtered reference voltage at the SENSE- pin must reach its final value within t_{SS}.

Typical values for the filter components are:

- R_F = 2.2kΩ
- C_F = 0.22μF

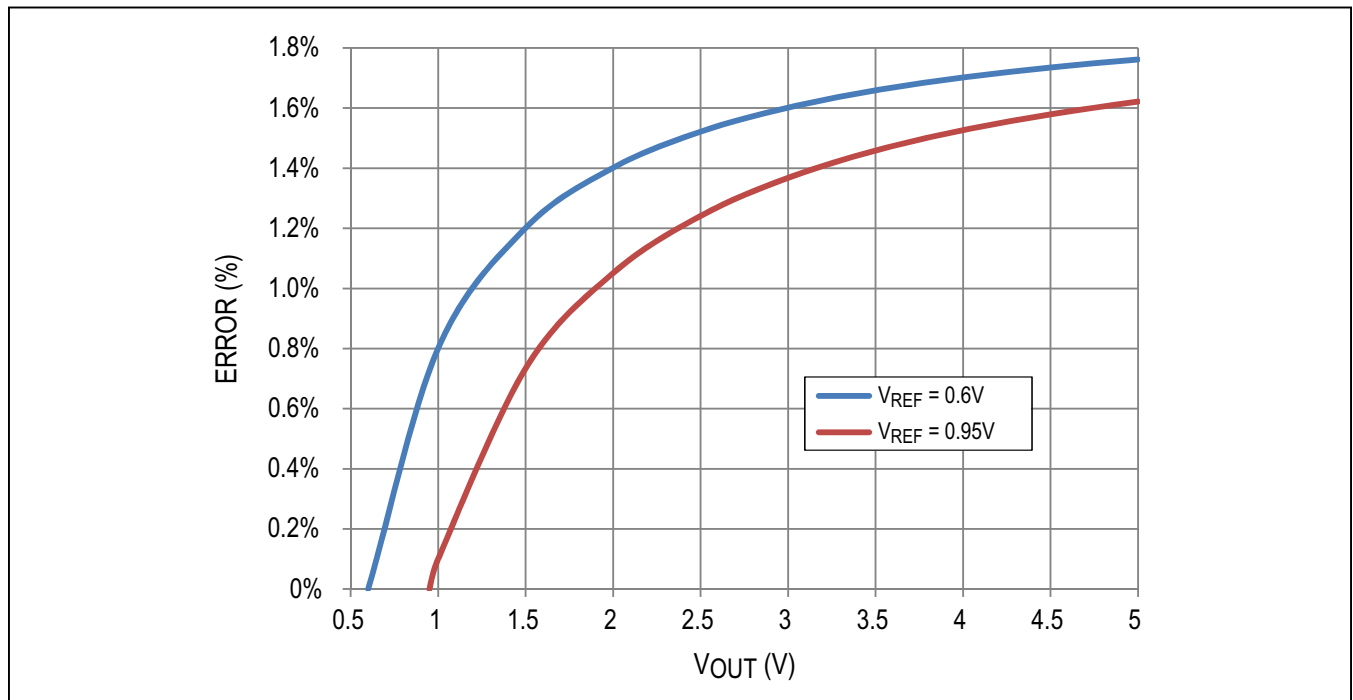

Figure 5. Contribution of 1% Tolerance Resistors on V_{OUT} Error

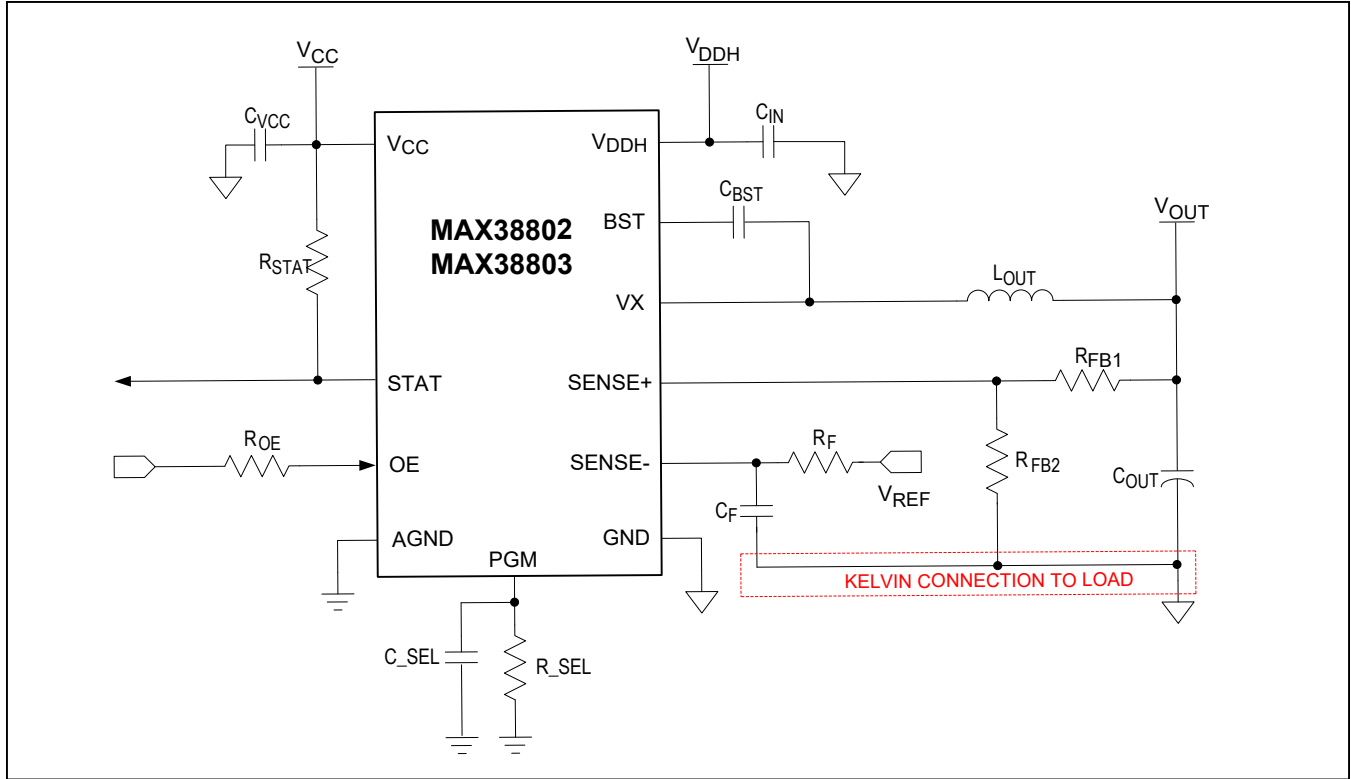

Figure 6. Electrical Connections to Use the External Voltage Reference Feature

Control Loop

The MAX38802/MAX38803 use Quick PWM architecture with current-sense signal added to feedback. Hence, without additional compensation, the voltage-loop gain consists of the following terms:

- The IC's current-mode control scheme has an effective transconductance gain of $1/R_{SENSE(GAIN)}$. See [Table 3a](#) and [3b](#) for correct $R_{SENSE(GAIN)}$ values.
- The output capacitors contribute an impedance gain of $1/(2 \times \pi \times C_{OUT} \times f)$.
- The feedback divider contributes an attenuation of $K_{DIV} = R_{FB2}/(R_{FB1} + R_{FB2})$.

Thus, when the ramp injection components (R_R, C_{R1}, C_{R2}), lead compensation components (C_{LEAD}, R_{LEAD}) and lag compensation components (R_{LAG}, C_{LAG}) are not used, the approximate loop gain and bandwidth (BW) are given by the following equations.

Equation 9

$$|Loop_Gain(f)| = \frac{K_{DIV}}{2 \times \pi \times R_{SENSE(GAIN)} \times C_{OUT} \times f}$$

$$BW = \frac{K_{DIV}}{2 \times \pi \times R_{SENSE(GAIN)} \times C_{OUT}}$$

or $BW = \frac{1}{2 \times \pi \times R_{GAIN_EFF} \times C_{OUT}}$

where, R_{GAIN_EFF} equals $R_{SENSE(GAIN)}/K_{DIV}$.

For stability, C_{OUT} should be chosen so that $BW < f_{SW}/3$. Designing with no loop compensation can result in fairly large C_{OUT} ; compensation schemes such as Lead, Lag and Ramp Injection can be used to allow C_{OUT} reduction. These compensations impact the transient performance as they change the BW of the system. This should be included in design analysis.

Integrator

The IC has an integrator included in its error amplifier to improve load regulation. The integrator only adds gain at low frequencies, so it does not affect the loop BW; therefore, it was not considered in previous equations. With the integrator, the loop gain from Equation 9 is multiplied by a factor of

$$(1/\tau_{REC} + s)/s$$

where, $\tau_{REC} = 20\mu s$.

Lag Compensation

In cases where the response is faster than desired, the lag compensation network (R_{LAG}, C_{LAG}) can be used to decrease the BW. This has the effect of lowering the gain contribution of the feedback network at higher frequencies, by effectively placing R_{LAG} in parallel with R_{FB2} . For the lag network to be effective and to achieve optimal phase margin, the zero at $1/(2 \times \pi \times R_{LAG} \times C_{LAG})$ should be placed at least a decade below the crossover frequency ($BW/10$).

Lead Compensation

In cases where the response is slower than desired, the lead compensation network (R_{LEAD}, C_{LEAD}) can be

used to increase the bandwidth. This has the effect of increasing the gain contribution of the feedback network at higher frequencies, by effectively placing R_{LEAD} in parallel with R_{FB1} .

For the lead network to be effective and to achieve optimal phase margin, the zero at $1/(2 \times \pi \times R_{LEAD} \times C_{LEAD})$ should be placed below the crossover frequency ($BW/10 < f_z < BW$).

External Ramp

The ramp compensation stabilizes the converter if the ESR of the output capacitor bank is low. The ramp is added to the internal current-sense signal at the error comparator inputs, which improves the signal-to-noise ratio and reduces the offtime jitter. By injecting a ramp on the feedback node, the same feedback error signal produces a smaller variation of the off time.

The amplitude of the external ramp is determined by R_R and C_{R2} (Figure 7). A voltage signal, which approximates the inductor current appears across C_{R2} and it is injected to the feedback node through C_{R1} .

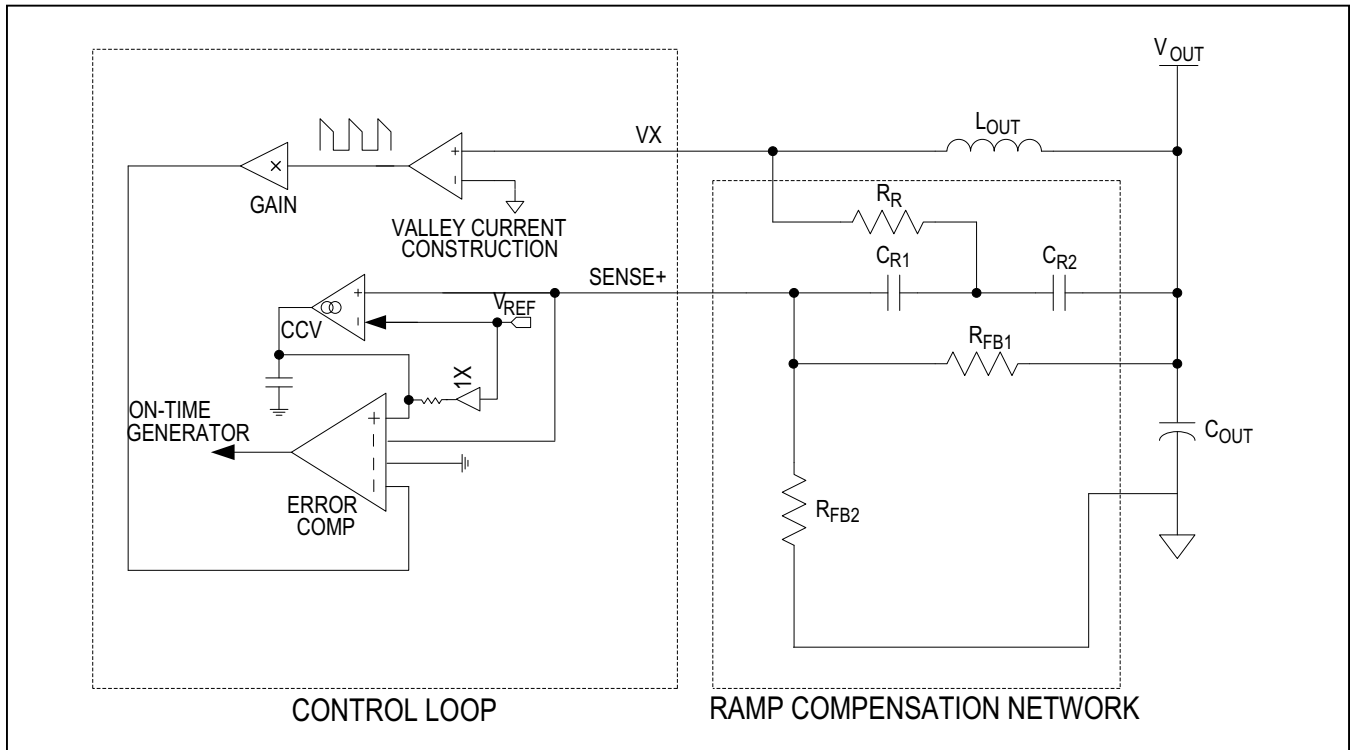

Figure 7. Ramp Compensation Diagram

Inductor Selection

The inductor value is selected based on the switching frequency and the percentage ratio of the inductor ripple to the peak load current (LIR - inductor current ratio).

Equation 10

$$L = \left[\frac{(V_{IN} - V_{OUT})}{f_{SW} \times I_{LOAD(MAX)} \times LIR} \right] \times \frac{V_{OUT}}{V_{IN}}$$

where:

LIR = Inductor current ratio
 $I_{LOAD(MAX)}$ = Peak load current

A lower LIR results in lower RMS losses in passive and active components, which improves the regulator efficiency. A higher LIR results in faster inductor current slew rate, better transient performance and lower inductor value/size. Optimal inductor selection is performed by evaluating these trade-offs according to design requirements.

The inductor must have a saturation current higher than the peak current during OCP event. The highest peak current is reached when a hard V_{OUT} short circuit is applied during operation (See Equation 11). In addition, the application circuit design must ensure that the peak current never exceeds the maximum operating current (I_{PK}) listed in the [Operating Ratings](#) section.

Equation 11

$$I_{SAT} = I_{OCP} + \frac{V_{OUT}}{L \times f_{SW}}$$

where:

I_{SAT} = Inductor saturation current
 I_{OCP} = Overcurrent protection threshold (see [Table 3a](#) and [3b](#))

Output Capacitor Selection

Output capacitor selection is based on output-ripple and load-transient requirements. Low ESR capacitors (MLCCs) are recommended to minimize ripple.

The output ripple is affected by three components: a resistive component due to effective ESR of the output capacitor bank, an inductive component due to parasitic inductance of the capacitor package (ESL) and capacitive component based on total C_{OUT} . See Equation 12 for an approximate expression of the output voltage ripple.

Equation 12

$$V_{PP} = ESR(I_{OUTRIPL}) + ESL \left(\frac{V_{IN}}{L_{OUT}} \right) + \left(\frac{I_{OUTRIPL}}{8 \times f_{SW} \times C_{OUT}} \right)$$

where:

ESR = Equivalent series resistance at the output
 $I_{OUTRIPL}$ = Peak-to-peak inductor current ripple
 ESL = High-frequency equivalent series inductance at output
 V_{IN} = Input voltage
 L_{OUT} = Output inductance
 f_{SW} = Switching frequency
 C_{OUT} = Output capacitance

Low ESR MLCC capacitors minimize the voltage drop due to fast load transients. Follow Equation 9 and the description in the [Control Loop](#) section to properly size the output capacitor bank.

In addition to output-voltage ripple and transient requirements for determining the output capacitance, ripple-current rating and power dissipation of the output capacitors should also be considered (Equation 13 and Equation 14).

Equation 13

$$I_{RMS_COUT} = \frac{I_{OUTRIPL}}{\sqrt{12}}$$

where $I_{OUTRIPL}$ equals peak-to peak ripple current value.

Equation 14

$$P_{COUT} = I_{RMS_COUT}^2 \times ESR$$

where ESR equals the equivalent series resistance of the entire output capacitor bank

Input Capacitor Selection

Input capacitors are designed to filter the pulsed current drawn by the switching regulator when the high-side FET is conducting. Filtering is primarily accomplished by the bulk input capacitors, while the high-frequency capacitors are used to minimize the parasitic inductance between the input supply and the voltage regulator. This arrangement minimizes the voltage transients during the commutations of high-side and low-side MOSFETs. For effective input decoupling, it is critical that the high-frequency decoupling

be placed in close proximity to the MAX38802/MAX38803 V_{DDH} and V_{SS} pins, and on the same side of the PCB board as the MAX38802/MAX38803. Follow [Table 4](#) for minimum input decoupling recommendations. It is also recommended to keep the input ripple below 3% of the DC voltage. To meet this target, additional capacitance can be required other than the minimum recommendations listed in [Table 4](#). Use Equation 15 to calculate total input capacitance based on desired peak-to-peak input-voltage ripple.

Equation 15

$$C_{IN} = \frac{I_{MAX} \times V_{OUT} \times (V_{DDH} - V_{OUT})}{(f_{SW} \times V_{DDH}^2 \times V_{DDH_P-P})}$$

where:

- C_{IN} = Input capacitance (MLCC)
- I_{MAX} = Maximum load current
- V_{DDH} = Input voltage
- V_{OUT} = Output voltage
- f_{SW} = Switching frequency (CCM)

V_{DDH_P-P} = Target peak-to-peak input-voltage ripple

Because of discontinuous current drawn from the input supply, the power-dissipation and ripple-current rating of input capacitors are more important than those of the output capacitors. Use Equation 16 to calculate the RMS current that the input capacitors must withstand. Multiple input caps can be placed in parallel to achieve the required total input RMS current rating.

Equation 16

$$I_{RMS_CIN} = \frac{I_{LOAD} \sqrt{V_{OUT}(V_{IN} - V_{OUT})}}{V_{IN}}$$

where I_{LOAD} equals the output DC load current

With an equivalent series resistance of the bulk input capacitor bank (ESR_{CIN}), the total power dissipation in the input capacitors is given by Equation 17.

Equation 17

$$P_{CIN} = I_{RMS_CIN}^2 \times ESR_{CIN}$$

Printed Circuit Board Layout

Careful PCB layout is critical to achieve low switching losses and clean, stable operation. The high current path requires particular attention. If possible, place all the power components on the top side of the board with their ground terminals flushed against one another. Follow these guidelines for good PCB layout:

1. Keep the power traces and load connections short. This is essential for high efficiency and stable operation. The use of thick copper PCBs (2oz vs. 1oz) can enhance full-load efficiency by 1% or more. Pay close attention to correct routing and PCB trace length reduction even by fraction of inches, where a single mΩ of excess trace resistance causes a measurable efficiency penalty. For maximum efficiency place the regulator, output inductor, and output capacitors as close as possible to the load. If this is not possible, keep the output capacitors close to the load and output inductor close to the regulator.
2. Keep the high-current traces (V_X , V_{DDH} , V_{CC} and BST) short and wide to minimize trace resistance and inductance. Traces connecting the input capacitors and V_{DDH} (power input node) on the IC require particular attention since they carry currents with the largest RMS values and fastest slew rates.
3. The input capacitors should be placed as close to the input supply pins (V_{DDH} and V_{SS}) as possible. High-frequency filter capacitors (see [Table 4](#)) must be

Table 4. Typical Boost, Filtering and Decoupling Capacitor Requirements

DESCRIPTION	VALUE	TYPE	PACKAGE	QTY
V_{CC} Capacitor	1μF/6.3V	X7R/125°C	0402/0603	1
Boost Capacitor	0.47μF/6.3V	X7R/125°C	0402	1
V_{DDH} HF Capacitor (Note 1)	1μF/16V	X7R/125°C	0603	1
V_{DDH} HF Capacitor (Note 1)	0.1μF/16V	X7R/125°C	0402	1
V_{DDH} Bulk Capacitor (Note 2)	10μF/16V	X5R	0805/1206	2

Note 1: All V_{DDH} high-frequency capacitors must be placed in close proximity to the slave IC and on the same side of the PCB as the slave IC. Refer to Maxim's layout guideline for component placement requirements and recommendations.

Note 2: For operation below 10.8V, two 22μF bulk capacitors are recommended instead of two 10μF capacitors.

placed within 60 mils of V_{DDH}/V_{SS} pins. V_{CC} and BST decoupling capacitors (see [Table 4](#)) must be placed on the same side of the PCB board as the IC. There should be an uninterrupted ground plane located immediately underneath these high-frequency current paths with the ground plane located no more than 8 mils below the top layer. By keeping the flow of this high frequency AC current localized to a tight loop at the regulator, electromagnetic interference (EMI) can be minimized.

4. Keep the sensitive analog signals away from high-speed switching nodes. The ground plane can be used to shield these sensitive signals and protect them from coupling of high-frequency noise. Voltage sense lines should be routed differentially with Kelvin connections to the load points. For remote-sense applications where the load and regulator IC are separated by a significant distance or impedance, it is important to place the majority of the output capacitors directly at the load for system stability. In remote-sense applications, common-mode filtering is necessary to filter high-frequency noise in the sense lines.

The following layout recommendations should be used for optimal performance:

- It is essential to have a low-impedance and uninterrupted ground plane under the IC and extended out underneath the inductor and output capacitor bank.
- Multiple vias are recommended for all paths that carry high currents (i.e., GND, V_{DDH} , VX). Vias should be placed close to the IC to create the shortest possible current loops. Via placement must not obstruct the flow of currents or mirror currents in the ground plane.
- A single via in close proximity to the chip should be used to tie the top layer AGND trace to the second layer ground plane. It must not be connected to the top power ground area.
- The feedback divider and compensation network should be close to the IC.

Gerber files with layout information and complete reference designs can be obtained by contacting a Maxim account representative.

MAX38802/MAX38803

Integrated, Step-Down Switching Regulator with Selectable Applications Configurations

Typical Application Circuit – 1V, 20A (MAX38802/MAX38803)

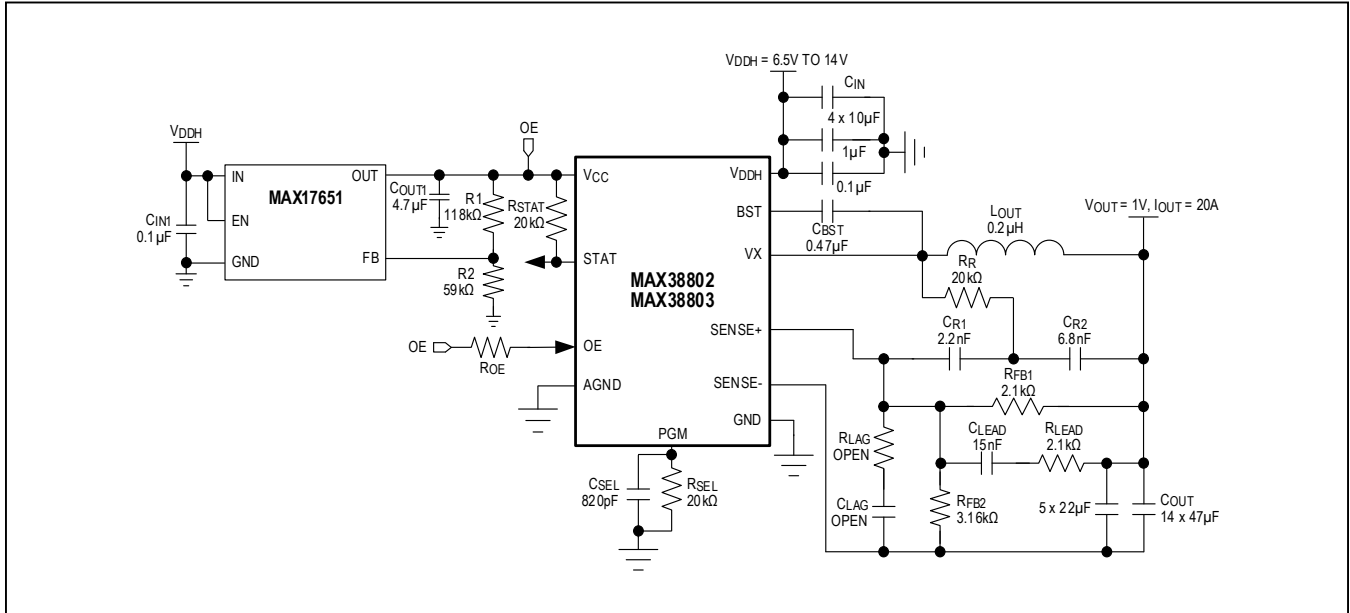

Typical Application Circuit – 2.5V, 20A (MAX38802/MAX38803)

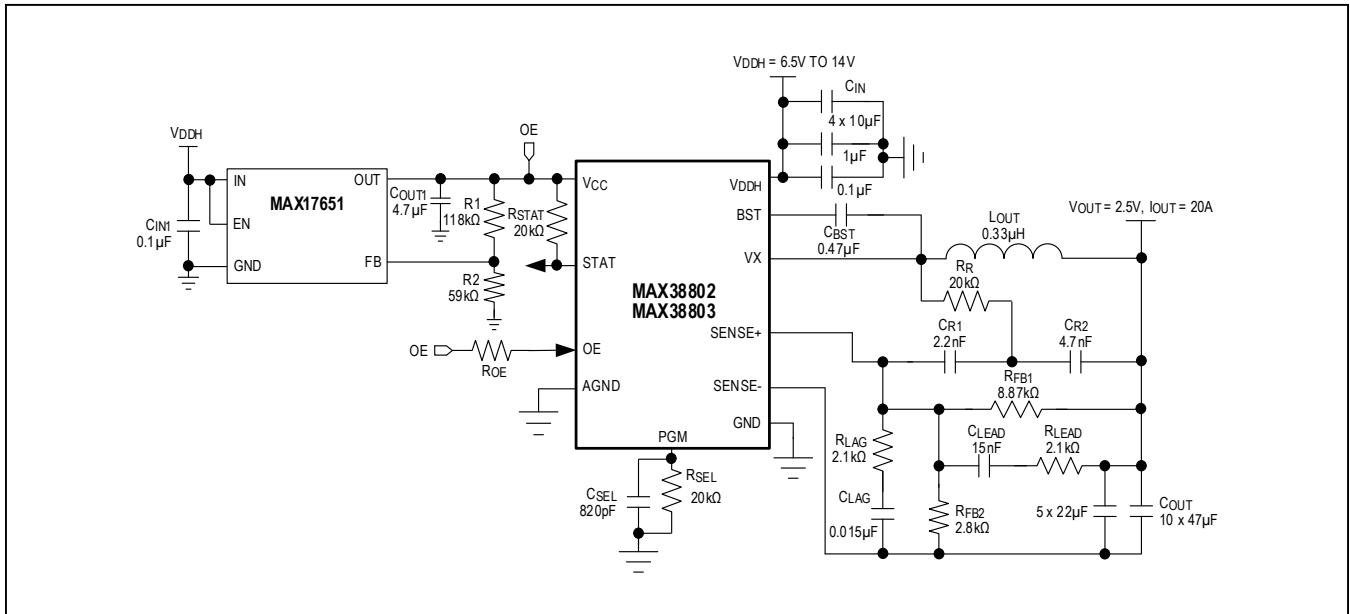

Typical Application Circuit – 2.5V, 12A (MAX38802)

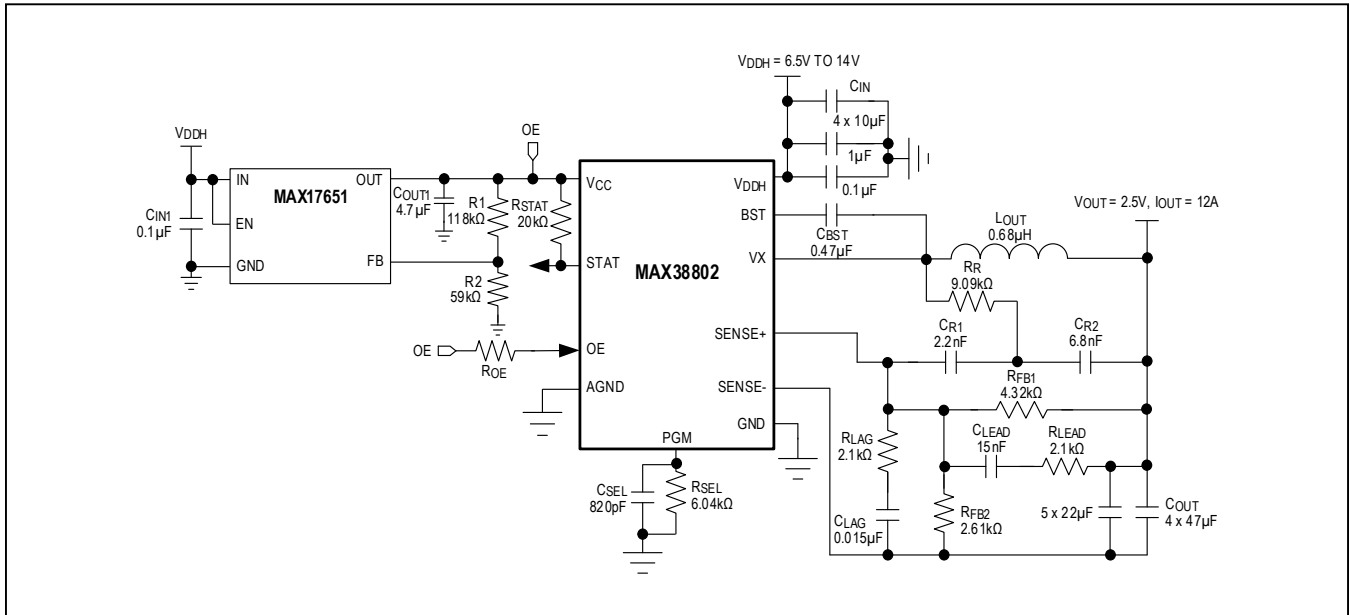

Typical Application Circuit – 5V, 18A (MAX38802/MAX38803)

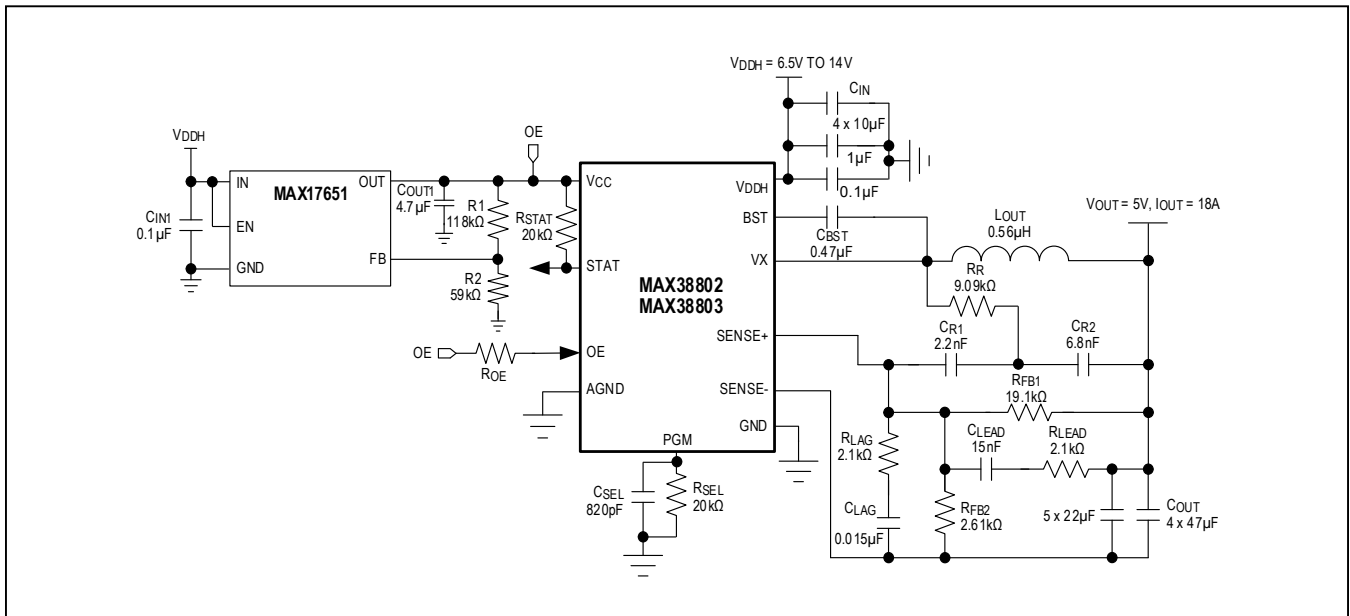

Typical Application Circuit – 2.5V, 12A (MAX38803)

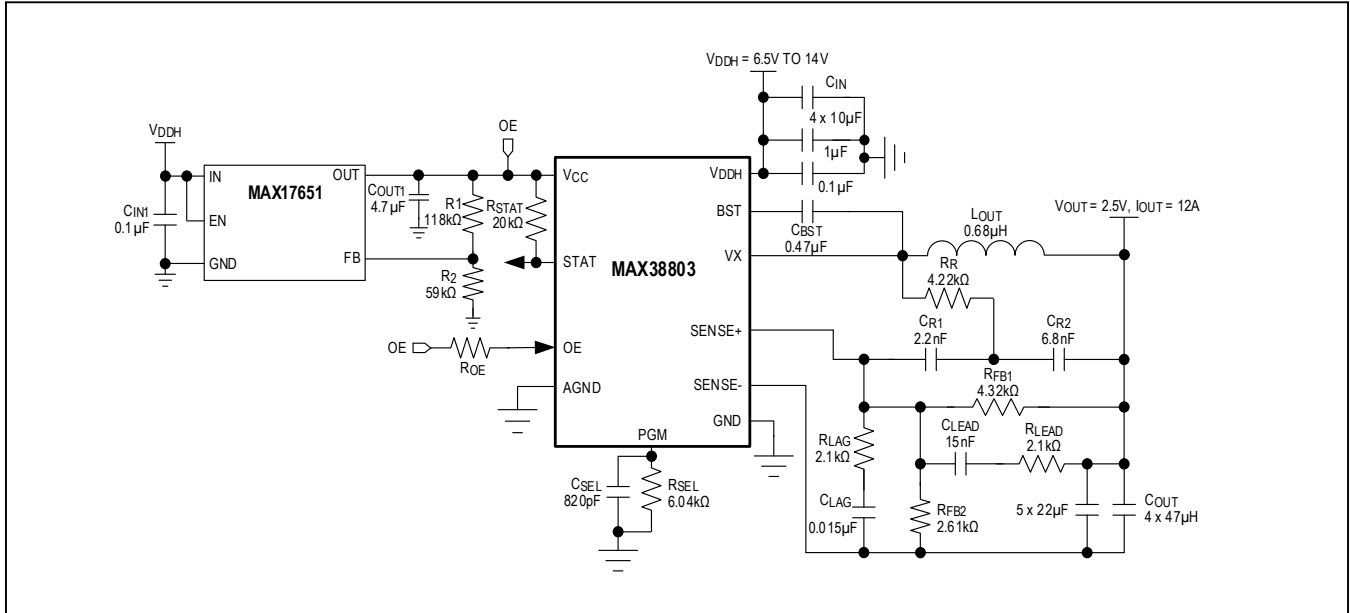

Ordering Information

PART NUMBER	PIN-PACKAGE	CURRENT LEVEL (A)	SHIPPING METHOD	PACKAGE MARKING
MAX38802HCJ+T	27-bump WLCSP	25	2.5ku Tape & Reel	MAX38802
MAX38803HCJ+T	27-bump WLCSP	25	2.5ku Tape & Reel	MAX38803

+Denotes a lead(Pb)-free/RoHS-compliant package.

T = Tape and Reel.

Revision History

REVISION NUMBER	REVISION DATE	DESCRIPTION	PAGES CHANGED
0	9/17	Initial data sheet	—
1	7/20	Updated Reference Design section, added schematics; release for intro	6, 25–31

For information on other Maxim Integrated products, visit Maxim Integrated's website at www.maximintegrated.com.

Maxim Integrated cannot assume responsibility for use of any circuitry other than circuitry entirely embodied in a Maxim Integrated product. No circuit patent licenses are implied. Maxim Integrated reserves the right to change the circuitry and specifications without notice at any time. The parametric values (min and max limits) shown in the Electrical Characteristics table are guaranteed. Other parametric values quoted in this data sheet are provided for guidance.