

MATERIALS AND FINISHES

BODY OUTER: BRASS  
PLATED SEE TABLE

BODY INNER: BRASS  
PLATED SEE TABLE

CONTACT: BRASS  
PLATED SEE TABLE

INSULATOR: TEFLON

RESISTOR: 2 100 OHM ±1% CHIP RESISTORS

ELECTRIAL PERFORMANCE:  
VSWR ≤ 1.20 THRU 6 GHZ  
VSWR ≤ 1.30 THRU 12 GHZ  
VSWR ≤ 1.35 THRU 18 GHZ

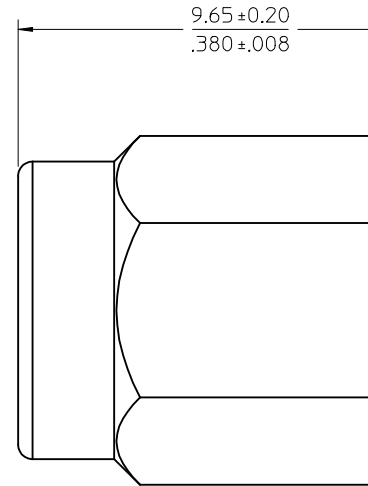
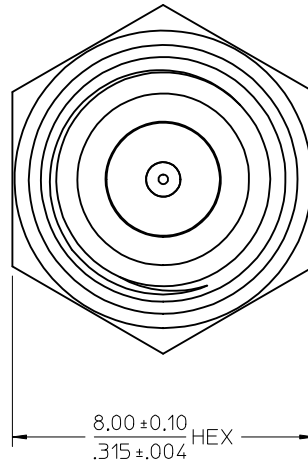
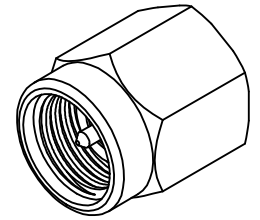

73391-0682	GOLD (10μ IN MIN)	GOLD (10μ IN MIN)	GOLD (30μ IN MIN)	-----
73391-0681	GOLD (FLASH)	GOLD (10μ IN MIN)	GOLD (10μ IN MIN)	73251-3490
73391-0680	NICKEL (100 μ IN)	GOLD (FLASH)	GOLD (10μ IN MIN)	73251-3491
PART NO.	OUTER BODY	BODY INNER	CONTACT	SAME AS
	FINISH	FINISH	FINISH	

MIL-STD-348A, FIG. 310.1	INTERFACE
SPECIFICATION	DESCRIPTION

<b>CHG: ADD TOLERANCES</b> EC NO: URF2013-0242 DRWN: JWIENER 2012/10/23 CHKD: SSS 2012/10/23 APPR: JWIENER 2012/10/25	QUALITY SYMBOLS ▽=0 ▽=0	GENERAL TOLERANCES (UNLESS SPECIFIED)	DIMENSION STYLE MM/IN	SCALE	DESIGN UNITS METRIC	THIRD ANGLE PROJECTION	
		4 PLACES ± --- ± --- 3 PLACES ± --- ± --- 2 PLACES ± --- ± --- 1 PLACE ± --- ± ---	DRAWN BY DATE CLLI 2004/02/17	CHECKED BY DATE K.C. 2004/02/17	TITLE SMA PLUG TERMINATION SMA-P, EWR-3728		
		ANGULAR ± 2 °	APPROVED BY DATE MISEN 2004/02/17	MOLEX MOLEX INCORPORATED			
		DRAFT WHERE APPLICABLE MUST REMAIN WITHIN DIMENSIONS	MATERIAL NO. SEE TABLE	DOCUMENT NO. SD-73391-068	SHEET NO. 1 OF 1		