

PROD		LOC	DIST	P		F		REVISIONS		DATE	APPD
CODE				ZONE	LTR	DESCRIPTION					
3321		DF	XO			REV & REDRAWN; 0600-1413-93 CT		9-94	JC		

ASSEMBLED VIEW

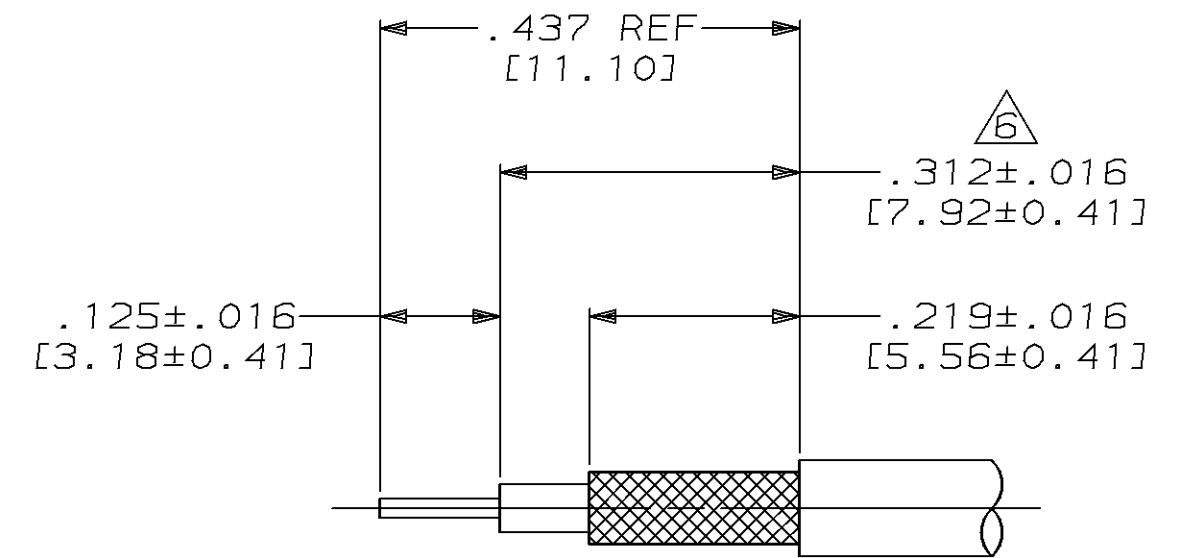

RECOMMENDED STRIP LENGTH
SCALE: N.T.S.

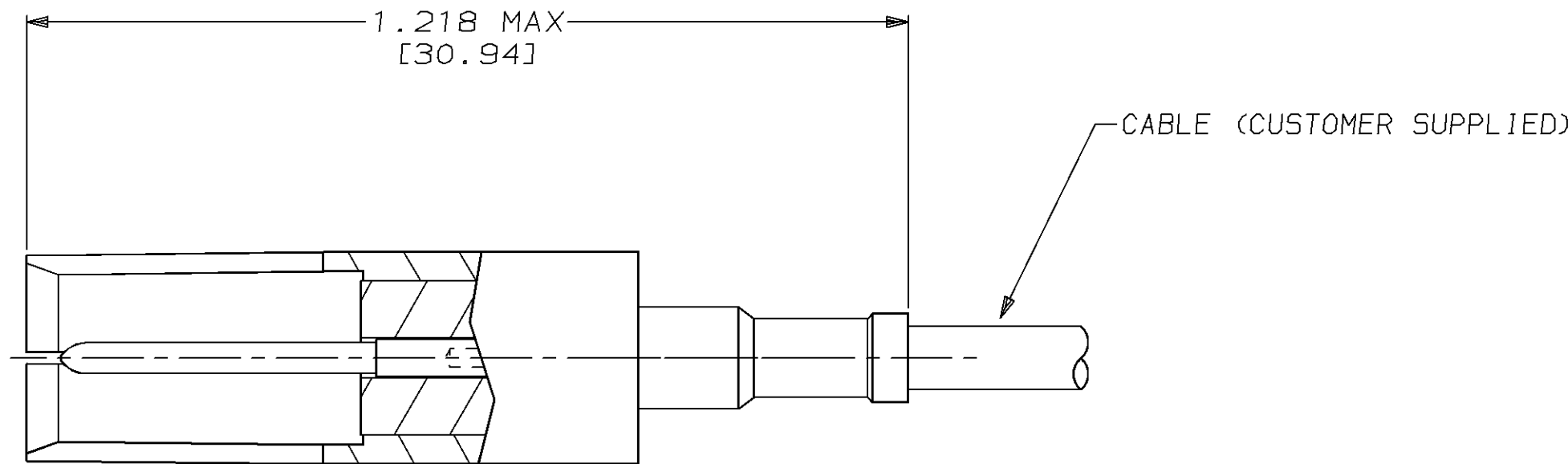
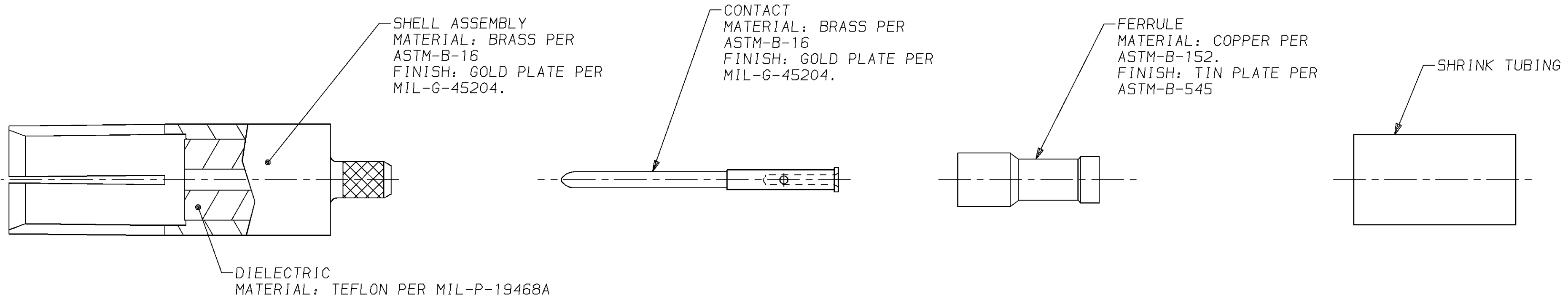

- FOR USE WITH RG-178/U & 196/U.
- FERRULE CRIMPING TOOL: AMP TOOL #220020-1.
- CONTACT CRIMPING TOOL: M22520/2-01 OR AMP TOOL NUMBER 1-601966-6, SETTING NUMBER 5. DANIELS POSITIONER PART NO. K345 OR AMP TOOL NO. 1-601966-6.
- SEE I.S.2348.
- DANIELS MANUFACTURING CORP
2266 FRANKLIN ROAD
BLOOMFIELD HILLS, MI 48013
- △ OUTER JACKET OF CABLE MUST BE TRIMMED TO ALLOW PROPER INTER-PIN CONTACT LOCATION AFTER FERRULE CRIMP OPERATION.
- PARTS SHIPPED UNASSEMBLED AND CABLE IS SUPPLIED BY CUSTOMER.

THIS DRAWING IS A CONTROLLED DOCUMENT FOR AMP INCORPORATED. IT IS SUBJECT TO CHANGE AND THE CONTROLLING ENGINEERING ORGANIZATION SHOULD BE CONTACTED FOR THE LATEST REVISION.

DO NOT SCALE PRINT. UNLESS SPECIFIED DIMENSIONS IN INCHES [mm]	DR 9-12-94 C.C. THOMAS
TOLERANCES ON :	CHK 9-23-94 J. CABARLO
2 PLC DEC ± -	APPD 9-23-94 J. CABARLO
3 PLC DEC ± -	APPD 9-23-94 C.C. THOMAS
ANGLES ± -	PRODUCT SPEC
MATERIAL	SEE CALLOUTS
FINISH	SEE CALLOUTS
WEIGHT	-

NAME	CONNECTOR, COAXIAL, RF SOCKET SIZE 5, ARINC (HEX CRIMP)	
SIZE	CAGE CODE	DRAWING NO
C	00779	C=225791-5
SCALE	5:1	SHEET 1 OF 1

AMP AMP Incorporated
Harrisburg, PA 17105-3608

225791-5
PART NO.