

DO NOT SCALE FROM THIS PRINT

EGBM-VT-X-XX.X-20

ORIENTATION
VT: VERTICAL

CARD SPACING
-20mm

LENGTH
-18.3 = 18.30mm
-25.3 = 25.30mm

THREADING
-1: EXTERNAL
-2: INTERNAL
(ONLY AVAIL. IN 25.3 LENGTH)

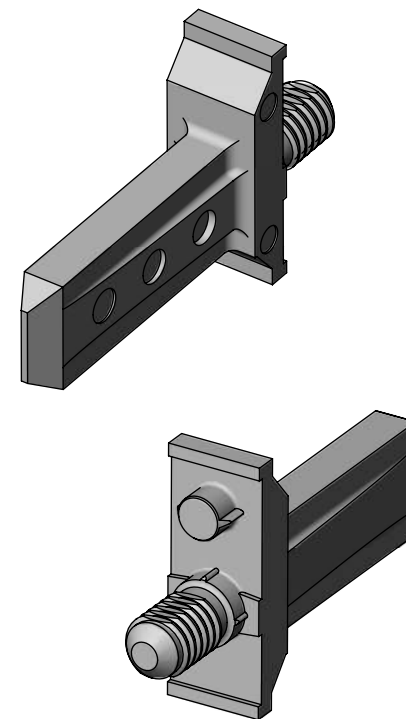
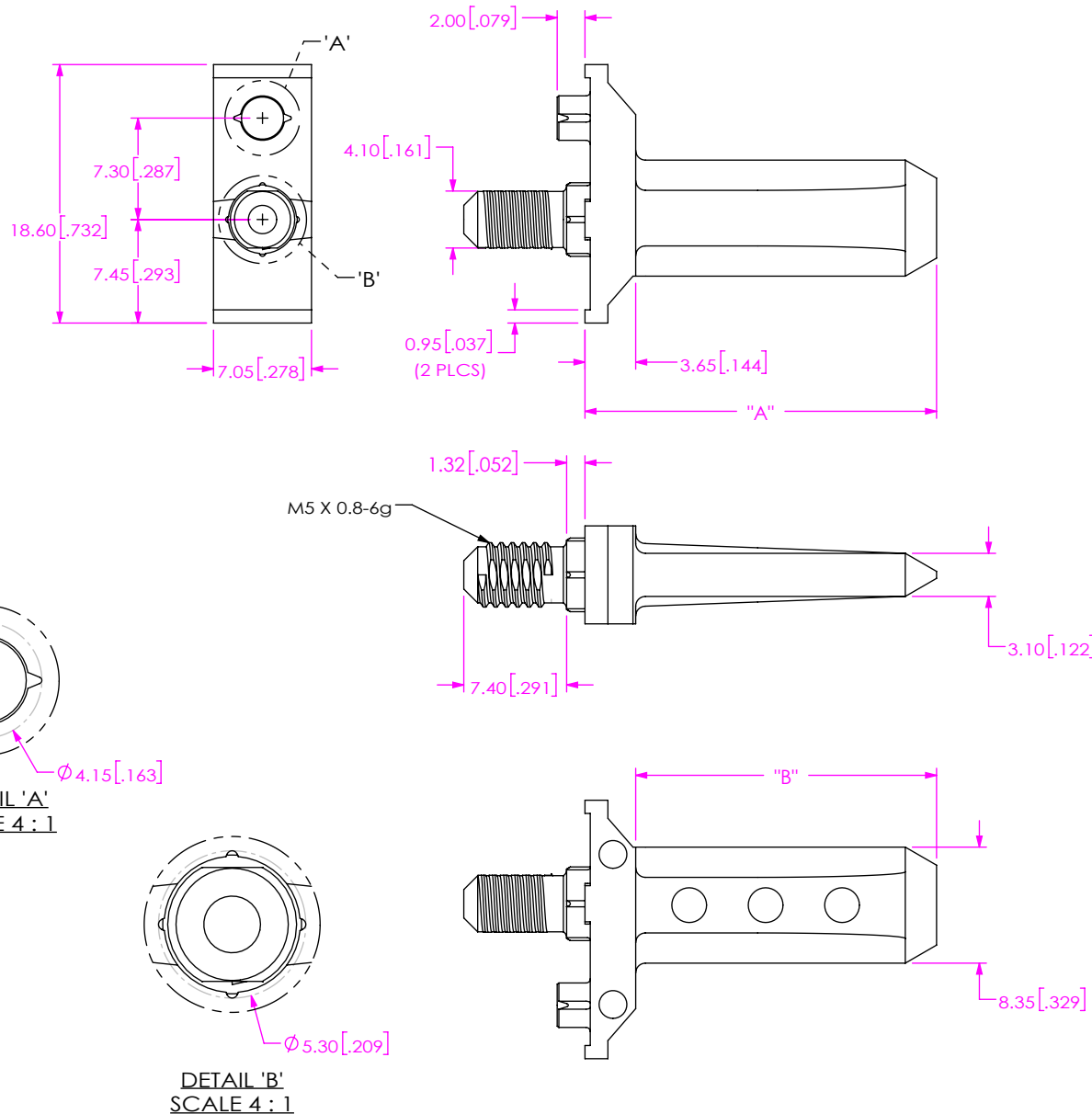

LENGTH	"A"	"B"
-18.3	18.30 [0.720]	14.65 [0.577]
-25.3	25.30 [0.996]	21.65 [0.852]

NOTES:

- STANDARD PACKAGING: USE ASBBLT6X8.5 BAG, 100 PCS MAXIMUM.
- SEE EGBM-VT-X-XX.X-XX-FOOTPRINT DRAWING FOR RECOMMENDED PCB LAYOUT AND INFORMATION REGARDING PCB LAYOUT OF GUIDE MODULES RELATIVE TO SIGNAL MODULES.

FIG 1
(EGBM-VT-1-XX.X-20 SHOWN)

<p>UNLESS OTHERWISE SPECIFIED, DIMENSIONS ARE IN MILLIMETERS [INCHES].</p>	<p>PROPRIETARY NOTE</p> <p>THIS DOCUMENT CONTAINS CONFIDENTIAL AND PROPRIETARY INFORMATION AND ALL DESIGN, MANUFACTURING, REPRODUCTION, USE, PATENT RIGHTS AND SALES RIGHTS ARE EXPRESSLY RESERVED BY SAMTEC, INC. THIS DOCUMENT SHALL NOT BE DISCLOSED, IN WHOLE OR PART, TO ANY UNAUTHORIZED PERSON OR ENTITY NOR REPRODUCED, TRANSFERRED OR INCORPORATED IN ANY OTHER PROJECT IN ANY MANNER WITHOUT THE EXPRESS WRITTEN CONSENT OF SAMTEC, INC.</p>	<p>samtec</p> <p>520 PARK EAST BLVD, NEW ALBANY, IN 47150 PHONE: 812-944-6733 FAX: 812-948-5047 e-Mail: info@SAMTEC.com code 55322</p>
	<p>DO NOT SCALE DRAWING SHEET SCALE: 2:1</p>	
<p>MATERIAL: ZINC ALLOY ZAMAK 3 (DIE CAST)</p> <p>FINISH: TRIVALENT CHROMIUM IRIDESCENT PASSIVATION OVER 5μ-8μ ZINC</p>	<p>DESCRIPTION: EXAMAX VERTICAL GUIDE BLADE</p> <p>DWG. NO. EGBM-VT-X-XX.X-20</p>	<p>BY: KNOWLDEN 9/9/2015 SHEET 1 OF 2</p>

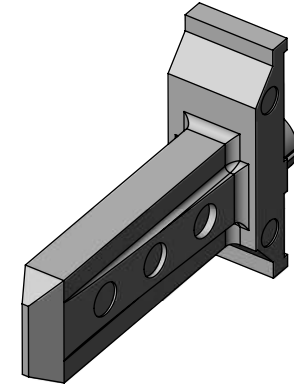
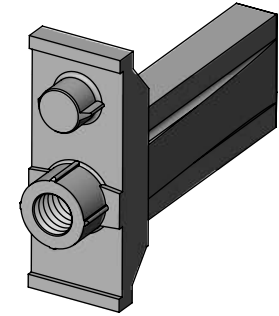
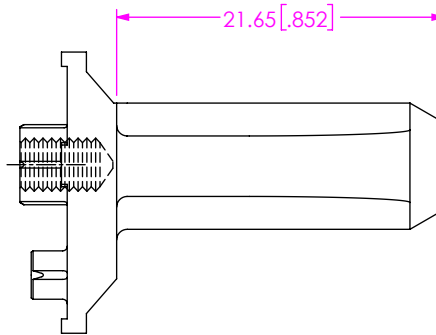
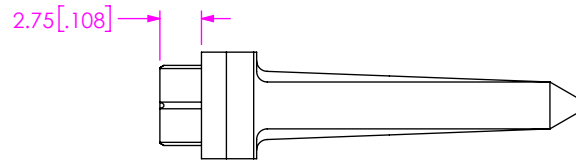
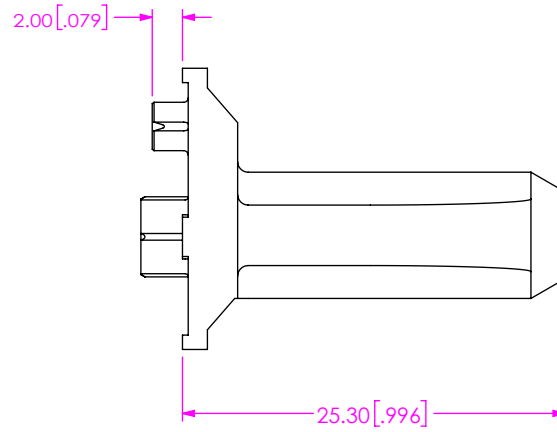
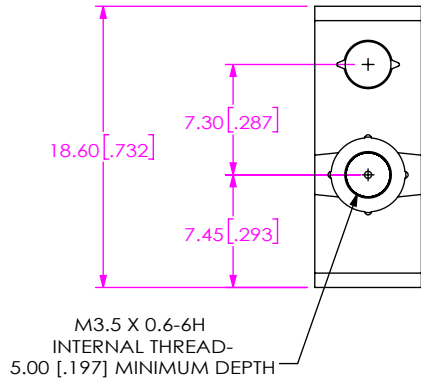

FIG 2
(EGBM-VT-2-XX.X-20 SHOWN)
(SAME AS FIG 1, EXCEPT AS SHOWN)

PROPRIETARY NOTE
THIS DOCUMENT CONTAINS CONFIDENTIAL AND PROPRIETARY INFORMATION AND ALL DESIGN, MANUFACTURING, REPRODUCTION, USE, PATENT RIGHTS AND SALES RIGHTS ARE EXPRESSLY RESERVED BY SAMTEC, INC. THIS DOCUMENT SHALL NOT BE DISCLOSED, IN WHOLE OR PART, TO ANY UNAUTHORIZED PERSON OR ENTITY NOR REPRODUCED, TRANSFERRED OR INCORPORATED IN ANY OTHER PROJECT IN ANY MANNER WITHOUT THE EXPRESS WRITTEN CONSENT OF SAMTEC, INC.



520 PARK EAST BLVD, NEW ALBANY, IN 47150
PHONE: 812-944-6733 FAX: 812-948-5047
e-Mail: info@SAMTEC.com code 55322

DO NOT SCALE DRAWING

SHEET SCALE: 2:1

DESCRIPTION:
EXAMAX VERTICAL GUIDE BLADE

DWG. NO.
EGBM-VT-X-XX.X-20

BY: KNOWLDEN 9/9/2015 SHEET 2 OF 2