

SPCM-AQ4C-IO

P/N 760-1

Interface Board for SPCM-AQ4C Modules

USERS GUIDE

Document # EO-674-04

SPCM-AQ4C-IO Interface Board for the SPCM-AQ4C Photon Counting Module

Users Guide

This manual applies to the SPCM-AQ4C-IO (Excelitas internal #760-1) interface board when used with the SPCM- AQ4C 4-channel single photon counting modules. This board is used to facilitate connecting power and signal connections to the SPCM-AQ4C modules for users who do not wish to build their own interface.

1. When handling the module, **ESD precautions** must be observed.
2. The SPCM-AQ4C module contains a high voltage power supply. When the board is under power, high voltages are present on the board. Keep fingers and tools away from the components on the board.
3. Do not touch the gold contacts on the card edge connector with bare fingers. Do not modify or adjust any components. Do not pull on the FC connectors to remove the module from the card edge connector.
4. The SPCM-AQ4C has been designed to operate from 5°C to 40°C (**10°C to 40° for CD3122 version**). Make sure that the heatsink has good airflow. The temperature of the heatsink will be determined by two factors. The first will be the ambient temperature of the system in which the card is installed. The second is determined by the count rate of the card. Higher count rates will cause the detector to heat up. In turn, the cooler circuit will compensate by transferring the heat from the detector to the heatsink. As the heatsink gets warmer, the operating margin (temperature) gets smaller. At 40°C, the dark count will be stable, but above 2Mcps the operation may become unpredictable.
5. Refer to the SPCM-AQ4C data sheet for performance and operating data.
6. Each detector is individually calibrated. Do not attempt to adjust any of the potentiometers or jumpers on the SPCM-AQ4C PCB. To do so could cause damage to the detector or the module electronics.
7. If the board is operated in high-level ambient lighting, some photons may enter the detector through the glass seal around the pins at the back of the detector assembly. Try to keep stray light from shining directly at the pins at the back of the detector assembly. The pins can be recognized by where they attach to the small flex circuit that connects the detector assembly to the PCB.
8. Use 18 gage wire or larger for the +2V supply and +2 V return. Keep the length as short as possible to avoid having a large voltage drop when the coolers are drawing maximum current (which can reach over 4 amps). If you need longer length, use heavier wire gage. You should design wiring harnesses to keep the total voltage drop to less than 100mV.

SPCM-AQ4C-IO
SPCM-AQ4C Interface Board

9. Connecting the Interface Board to the SPCM-AQ4C Module. Note that a power cable is supplied with each I/O board.

9.1. Locate the position of the key slot on the SPCM PCB before attempting to mate the module to the interface board. Refer to the connector pin-out diagram and figure 9.1.

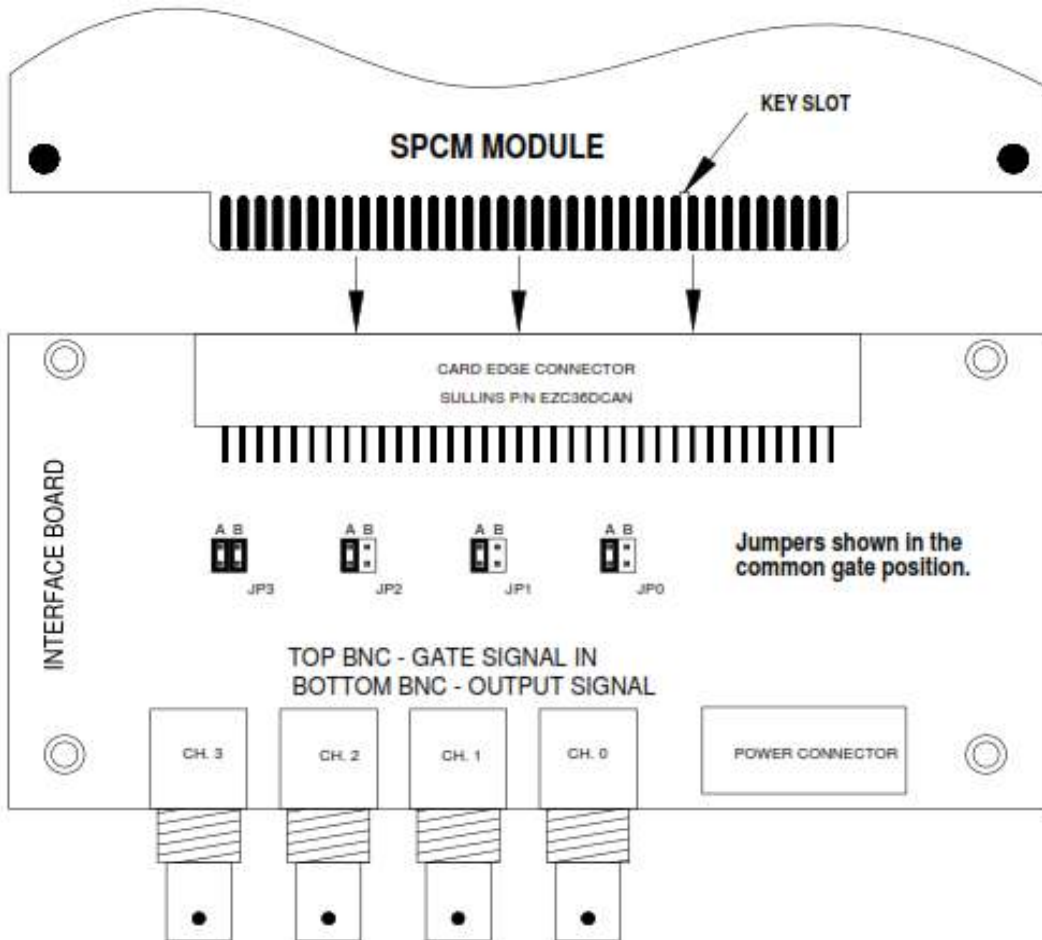

INDEPENDENT GATE INPUT JUMPER SETTINGS		
Jumper	Position A	Position B
JP0	--	X
JP1	--	X
JP2	--	X
JP3	--	X

COMMON GATE INPUT JUMPER SETTINGS		
Jumper	Position A	Position B
JP0	X	--
JP1	X	--
JP2	X	--
JP3	X	X

FIGURE 9.1 JUMPER SETTING FOR GATE CONTROL

SPCM-AQ4C-IO SPCM-AQ4C Interface Board

- 9.2. Jumper Positions: There are a number of jumpers on the interface board that control how the gating functions of the module operate. The interface board can be configured to allow independent gating of each channel or it can be configured to allow simultaneous gating of all the channels from one GATE input.
- 9.3. As shipped, the I/O board has been configured to gate all channels of each module simultaneously. The gating can be accomplished by using a TTL level signal capable driving a 50 ohm load (100mA @ 5V). The signal can be connected to any one of the GATE Input connectors and all channels will be controlled in parallel.
- 9.4. To convert to independent gating of the channels, refer to the table in figure 9.1. You will need a different signal source for each channel that you want to gate.
- 9.5. Note that with no gate signal or floating gate inputs, the module will be in the gated "ON" position and ready to count photons.
- 9.6. The module channels will be "GATED ON" with a low-level TTL (<0.8V) signal applied to the gate connector. A high level TTL (>2V, <5.25) signal applied to the gate connector will gate the module channels off.
- 9.7. OUTPUT. The *output* of each channel is a TTL level signal and is *obtained from the bottom BNC connector* for each channel. **EACH** output channel **MUST** be **terminated** into a 50-ohm load at the measurement source (counter, scope, etc) for correct operation. Refer to figure 9.2.

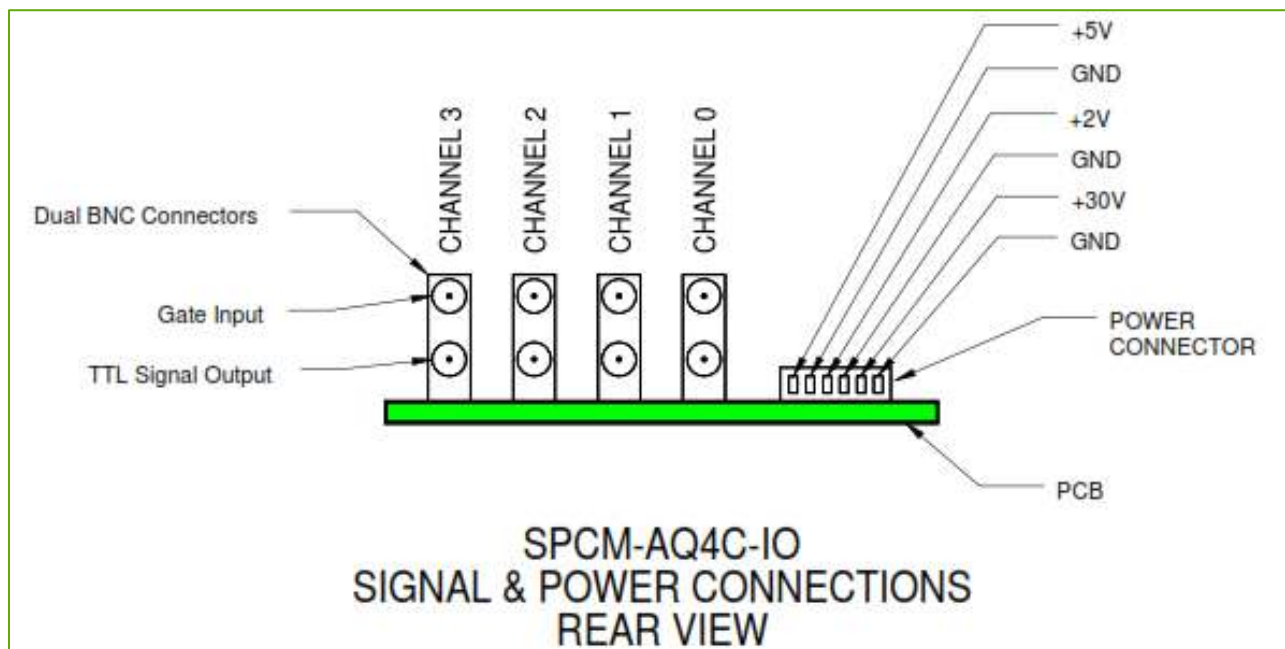

FIGURE 9.2 REAR PANEL

10. Power Cable Connections

10.1. Refer to figure 10.1 for wiring connections.

10.2. As usual, cables should be kept as short as possible to minimize voltage drops in the wires. Minimize potential ground loops by connecting ground wires at a single point.

10.3. The power supplies that you choose should be well-regulated and low noise. Ripple and noise should be kept below 50mV p-p. Each photon-counting channel is internally protected from current overloads. However, it is always prudent to use power supplies that are capable of current limiting to the maximum specified current for each module.

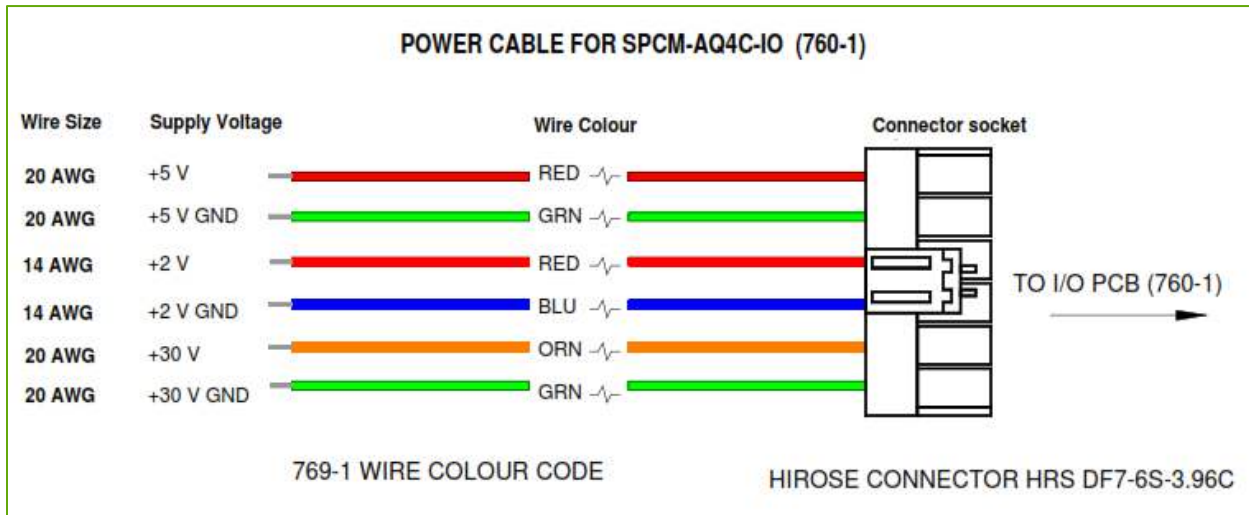

Figure 10.1 Power Connector Wiring

11. Mechanical Dimensions

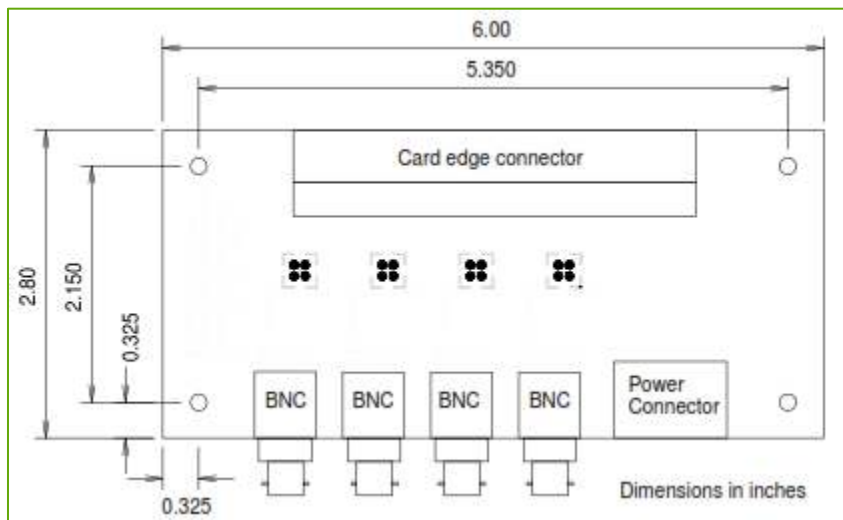

Figure 11.1 Dimensions in inches

SPCM-AQ4C-IO SPCM-AQ4C Interface Board

RoHS Compliance

The SPCM-AQ4C-IO is designed and built to be fully compliant with the European Union Directive 2011/65/EU – Restriction of the use of certain Hazardous Substances (RoHS) in Electrical and Electronic equipment.



Warranty

A standard 12-month warranty following shipment applies. Any warranty is null and void if the photodiode window has been opened.

About Excelitas Technologies

Excelitas Technologies is a global technology leader focused on delivering innovative, customized solutions to meet the lighting, detection and other high-performance technology needs of OEM customers.

Excelitas has a long and rich history of serving our OEM customer base with optoelectronic sensors and modules for more than 45 years beginning with PerkinElmer, EG&G, and RCA. The constant throughout has been our innovation and commitment to delivering the highest quality solutions to our customers worldwide.

From analytical instrumentation to clinical diagnostics, medical, industrial, safety and security, and aerospace and defense applications, Excelitas Technologies is committed to enabling our customers' success in their specialty end-markets. Excelitas Technologies has approximately 5,000 employees in North America, Europe and Asia, serving customers across the world.

Excelitas Technologies
22001 Dumberry Road
Vaudreuil-Dorion, Quebec
Canada J7V 8P7
Telephone: (+1) 450 424 3300
Toll-free: (+1) 800 775 6786
Fax: (+1) 450 424 3345
detection@excelitas.com

Excelitas Technologies
GmbH & Co. KG
Wenzel-Jaksch-Str. 31
D-65199 Wiesbaden
Germany
Telephone: (+49) 611 492 430
Fax: (+49) 611 492 165
detection.europe@excelitas.com

Excelitas Technologies Singapore, Pte. Ltd.
8 Tractor Road
Singapore 627969
Telephone: (+65) 6775 2022 (Main number)
Telephone: (+65) 6770 4366 (Customer Service)
Fax: (+65) 6778-1752
detection.asia@excelitas.com



For a complete listing of our global offices, visit www.excelitas.com/locations

© 2015 Excelitas Technologies Corp. All rights reserved. The Excelitas logo and design are registered trademarks of Excelitas Technologies Corp. All other trademarks not owned by Excelitas Technologies or its subsidiaries that are depicted herein are the property of their respective owners. Excelitas reserves the right to change this document at any time without notice and disclaims liability for editorial, pictorial or typographical errors.