

VSML2512S5 Series, Current Sensor Resistor (Lead / Halogen Free)

Features / Applications :

- High power rating is up to 5W
- Welding construction; excellent long-term stability
- Automotive applications & Current Sensor Resistor
- Suggested mounting on DBC/IMS/FR4 substrate
- RoHS compliant and AEC Q200 qualified

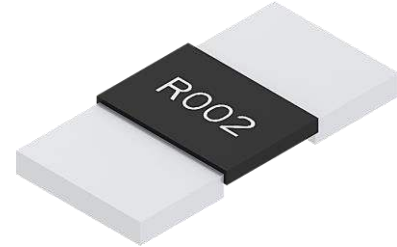

Electrical Specifications :

Characteristics ¹	Feature
Power Rating ²	5 W
Resistance Value	2 mΩ
Temperature Coefficient of Resistance (25/125°C)	±75 ppm/°C
Operation Temperature Range	-65°C ~ +170°C
Resistance Tolerance	± 1%
Maximum Working Voltage (V)	(P*R) ^{1/2}

1. For detail information refer to the table on page 3 P/N list

2. For resistors are operated at terminal temperature in excess of 100°C, the maximum load shall be derated in accordance with the following curve.

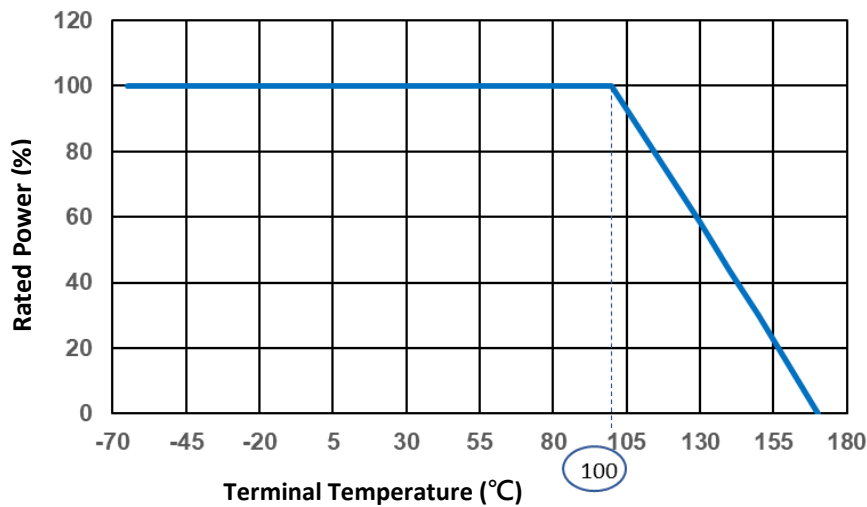
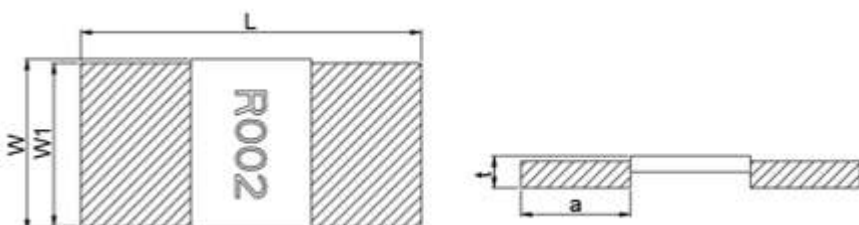

Figure 1. : Power derating curve at terminal temperature

Outline Drawing :

Construction and Dimension



Dimensions (mm)	
Resistance Range (mΩ)	2
L	6.35 ± 0.25
W	3.20 ± 0.25
W1	3.05 ± 0.15
t	0.60 ± 0.25
a	2.05 ± 0.25

Recommended Solder Pad Dimensions

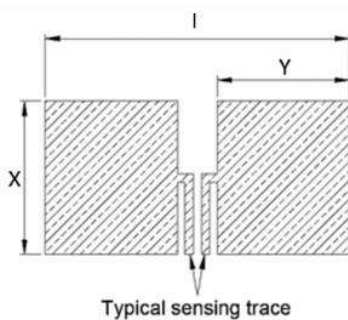

Resistance Range	Dimensions		
mΩ	X (mm)	Y (mm)	I (mm)
2	3.7	3.2	7.35

Type Designation :

V S M L 2512 S 5 — □□□□ □
 (1) (2) (3) (4) (5) (6)

Note :

- (1) Series No.
- (2) Size
- (3) Terminal Type : S = Short terminal
- (4) Power Rating : 5 = 5W
- (5) Resistance value : R002 = 0.002Ω
- (6) Tolerance : F = ±1%, G = ±2%, J = ±5%

P/N list :

P/N	R value	TCR	Power Rating	Tolerance		
	(mΩ)	(ppm/K)	(W)	1%	2%	5%
VSML2512S5-R002*	2.0	±75	5	✓		

* Note : Other values and tolerance would be available, please contact Cyntec.

Characteristics :

Electrical

Item	Specification and Requirement	Test Method
Temperature Coefficient (TCR)	As follow specification	JIS-C-5201 +25°C/ +125°C.
Short Time Overload	$\Delta R: \pm 0.5\%$ Without damage by flashover, spark, arcing, burning or breakdown	JIS-C-5201-1 4.13 2.5 x rated power for 5 seconds.
ESD	$\Delta R: \pm 1\%$ Without damage by flashover, spark, arcing, burning or breakdown	AEC-Q200-002 Human body, 8KV.
Insulation Resistance	Over 100 M Ω on Overcoat layer face up	JIS-C-5201-1 4.6 100V _{DC} for 60 +10/-0 seconds
Voltage Proof	$\Delta R: \pm 1\%$ Without damage by flashover, spark, arcing, burning or breakdown	JIS-C-5201-1 4.7 400V _{AC} (rms.) for 60 +10/ -0 seconds

Mechanical

Item	Specification and Requirement	Test Method
Solderability	The surface of terminal immersed shall be minimum of 95% covered with a new coating of solder	J-STD-002 Method B category 3 245 \pm 5°C for 5 \pm 0.5 seconds.
Resistance to Solder Heat	$\Delta R: \pm 0.5\%$ Without distinct damage in appearance	MIL-STD-202 Method 210 260 \pm 5°C for 10 \pm 1 seconds.
Board Flex	$\Delta R: \pm 1.0\%$ Without mechanical damage such as break.	AEC-Q200-005 Bending value: 2 mm for 60 \pm 1 seconds.
Vibration	$\Delta R: \pm 0.5\%$ Without distinct damage in appearance	MIL-STD-202 Method 204 5G's for 20 minutes, 12 cycles each of 3 orientations. Test from 10-2000Hz.



Current Sensor Resistor

Mechanical Shock	$\Delta R: \pm 0.5\%$ Without distinct damage in appearance	MIL-STD-202 Method 213 100G's peak value, 6ms, Half-sine waveform, 12.3ft/sec.
Terminal Strength (SMD)	$\Delta R: \pm 1\%$ Without mechanical damage such as break.	AEC-Q200-006 Force of 1.8Kg for 60 seconds.

Endurance

Item	Specification and Requirement	Test Method
Temperature Cycling	$\Delta R: \pm 0.5\%$ Without distinct damage in appearance	JESD22 Method JA-104 -55°C to 150°C /1000cycle 30 min maximum dwell time at each temperature on FR4(PCB).
Biased Humidity	$\Delta R: \pm 0.5\%$ Without distinct damage in appearance	MIL-STD-202 Method 103 1000 hours, 85°C /85%R.H, applied for 10% rated power.
Operational Life	$\Delta R: \pm 1.0\%$ Without distinct damage in appearance	MIL-STD-202 Method 108 70°C, 100% rated power 1.5 hours ON, 0.5 hours Off For total 1000 hours
High Temperature Storage	$\Delta R: \pm 1.0\%$ Without distinct damage in appearance	MIL-STD-202 Method 108 170°C for 1000 hours.
Moisture Resistance	$\Delta R: \pm 0.5\%$ Without distinct damage in appearance	MIL-STD-202 Method 106 65°C /90-100%RH, unpowered, 7b not required

Note : Measurement at 24±4 hours after test conclusion for all reliability tests-parts.

PACKAGING DESCRIPTIONS :

Dimensions :

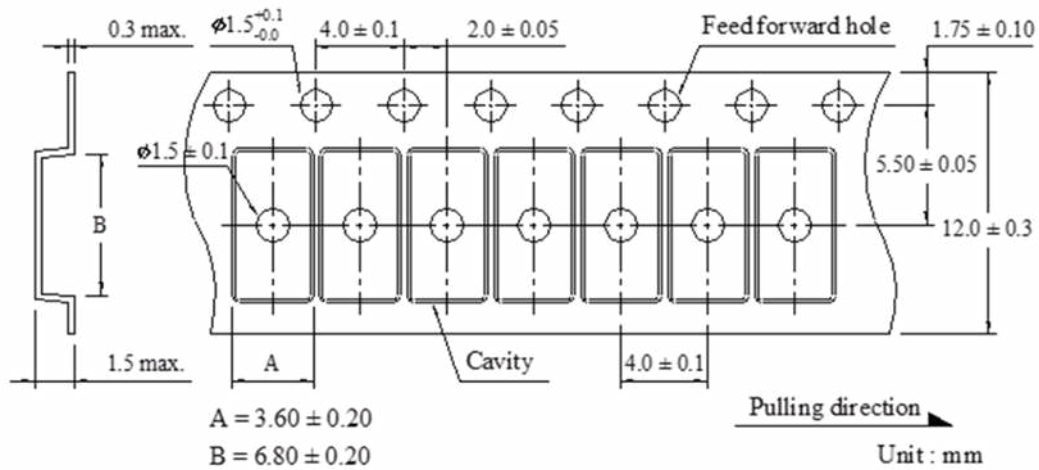

Reel dimensions :

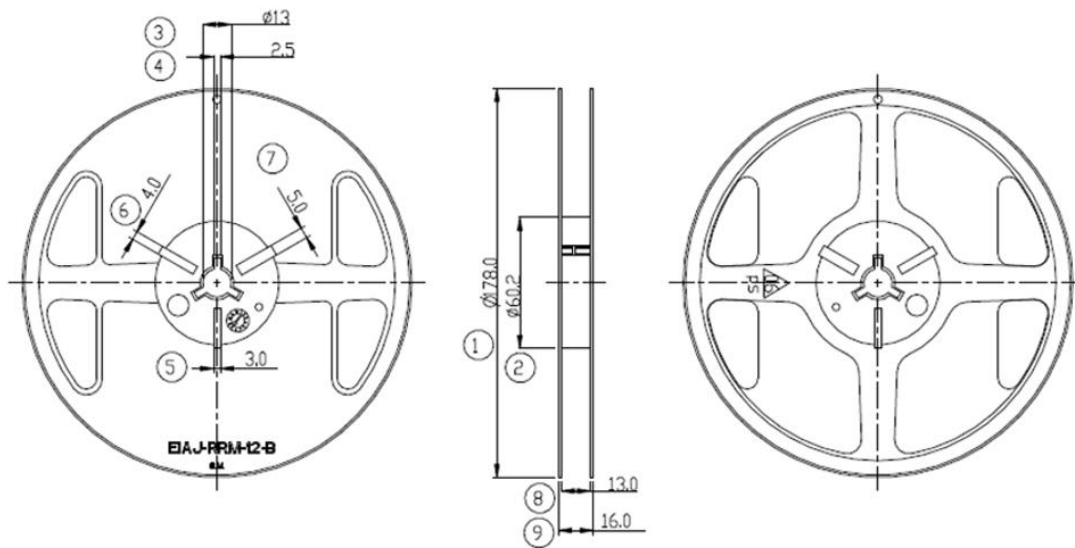

Unit:mm

Symbol	1	2	3	4	5	6	7	8	9
Size	178.0 ± 1	60.2 ± 0.5	13.0 ± 0.5	2.5 $+0.5/-0$	3.0 $+0.5/-0$	4.0 $+0.5/-0$	5.0 $+0.5/-0$	13.0 ± 0.5	16.0 ± 0.15

Peel Strength of Top Cover Tape :

The peel speed shall be about 300mm/min and the peel force of top cover tape shall between 0.1 to 0.7N

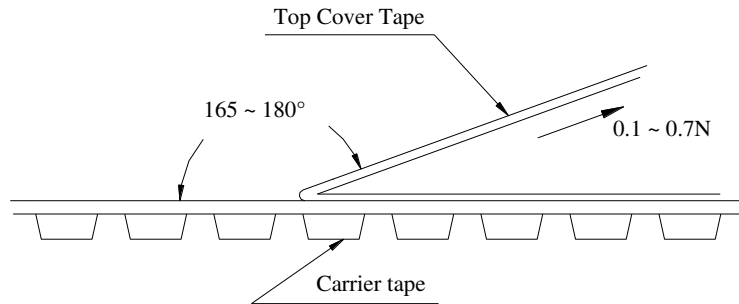

Number of Taping :

2,000 pieces / reel

Label Marking :

The following items shall be marked on tray

- (1) Description
- (2) Quantity
- (3) Part No.
- (4) Tapping No.

Care Note :

Care note for storage

- (1) Chip resistor shall be stored in a room where temperature and humidity must be controlled.
(temperature 5 to 35°C, humidity < 60% RH) However, a humidity keep it low, as it is possible.
- (3) Chip resistor shall be stored as direct sunshine doesn't hit on it.
- (4) Chip resistor shall be stored with no moisture, dust, a material that will make solderability inferior, and a harmful gas (Chloridation hydrogen, sulfurous acid gas, and sulfuration hydrogen)

Care note for operating and handling

- (1) Protect the edge and coating of the sensors from mechanical stress.
- (2) Avoid bending of printing circuit board (PCB) when cutting and fixing it on support body to reduce mechanical stress on sensors.
- (3) Sensor should be used within the condition of specification.
Note: When a voltage higher than specified value is loaded to the sensor, this may damage the sensor material due to temperature rise.
- (4) The loaded voltage should consult terminal temperature of the sensor according to the derating curve.
- (5) When applying a high current exceeding suggested specification (pulse current, shock current) to the sensor, it is necessary to re-evaluate the operating condition before using it in the system.

Reflow profile :

Recommended Reflow Profile

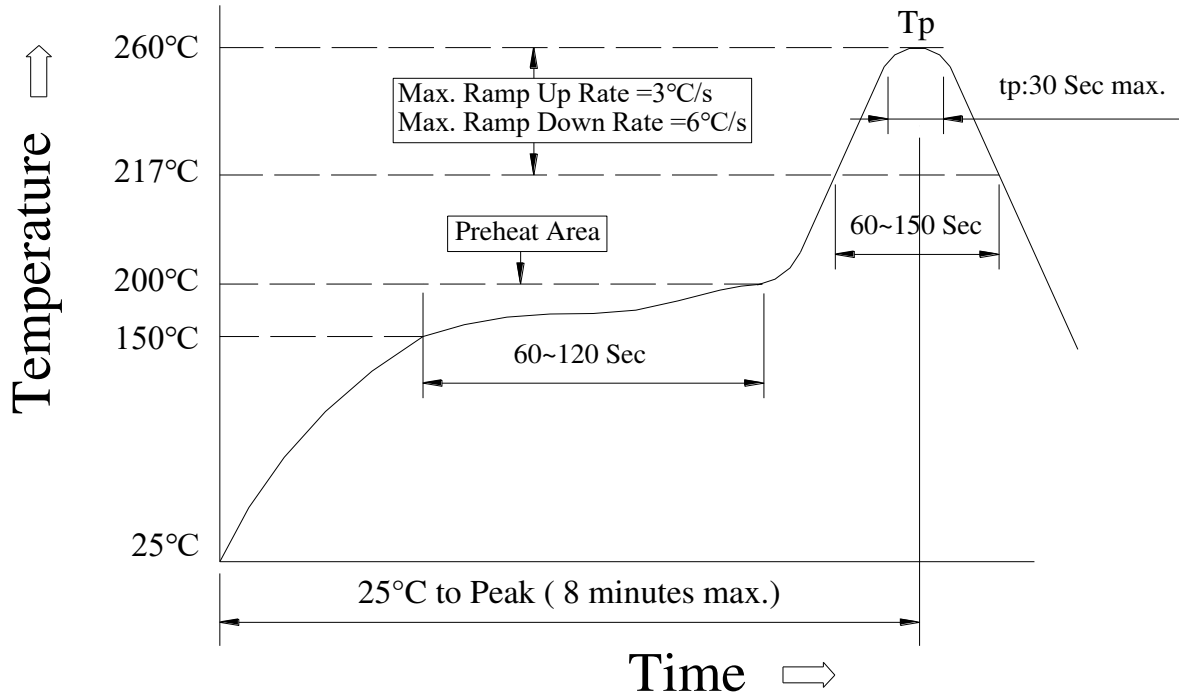

(1) Reflow Soldering Method :

Reflow Soldering	Tp:255~260°C	Max.30 seconds (tp)
	217°C	60~150 seconds
Pre-Heat	150 ~ 200°C	60~120 seconds
Time 25°C to peak temperature	8 minutes max.	

Reference : JEDEC J-STD-020E