

REVISIONS

P	LTR	DESCRIPTION	DATE	DWN	APVD
	A	INITIAL RELEASE PER DCR# R050445	02DEC2005	-	MH
	B	REVISED PER ECO-16-001928	15FEB2016	KK	MP

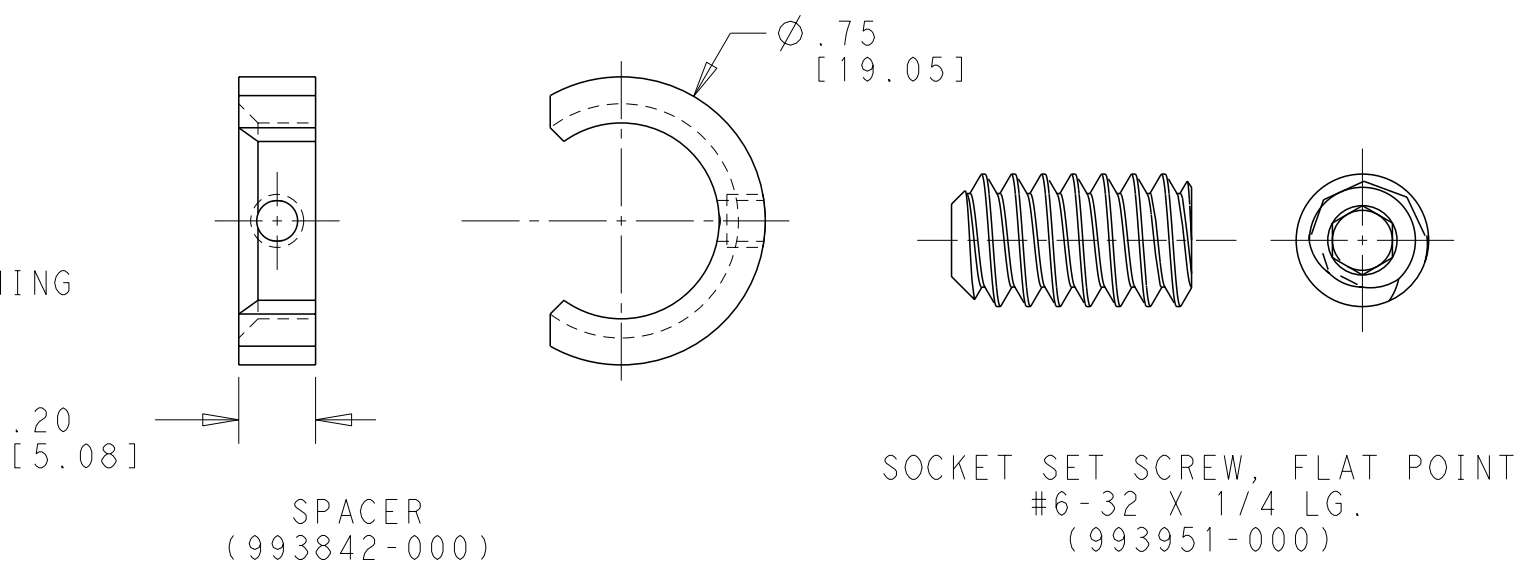
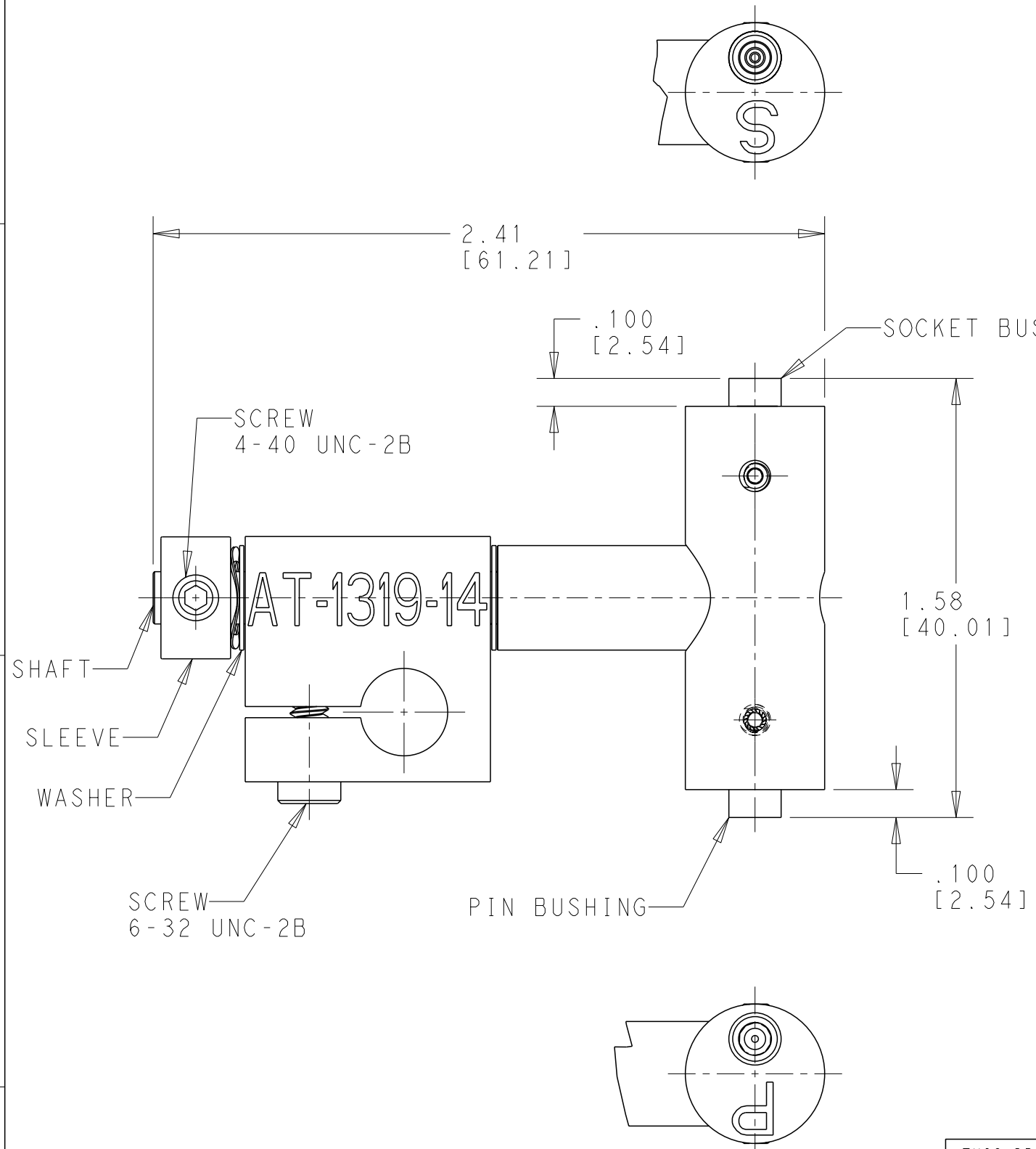

- NOTES;
- FOR TERMINATION INSTRUCTION AND APPLICATIONS SEE ENGINEERING STANDARD (ES-61199).
  - MATERIAL: ADAPTER HOUSING: ALUMINIUM 6061-T6 PER ASTM B221, FINSH: CLEAR ANODIZED.  
SHAFT, SLEEVE AND BUSH HOUSING: 303 STAINLESS STEEL PER ASTM A484.  
BUSHING INNER STOP: BRASS 360 1/2 HARD PER ASTM B16/16M.  
WASHER: 18-8 STAINLESS STEEL.  
SCREW: 4-40 UNC-2B SOCKET SETSCREW, STAINLESS STEEL  
6-32 UNC-2B UNC-2B SOCKET HEAD SCREW, STAINLESS STEEL.

748 SOLDER TACT ADAPTOR ASSEMBLY  
(993877-000)

748 SOLDER TACT ADAPTOR	993877-000
DESCRIPTION	PART NO.

THIS DRAWING IS A CONTROLLED DOCUMENT.		DWN KIRAN K 15FEB2016	TE Connectivity													
DIMENSIONS: INCHES [MM]		CHK N. NAGAR 15FEB2016														
TOLERANCES UNLESS OTHERWISE SPECIFIED:		APVD M. POPE 15FEB2016	NAME 748 SOLDER TACT ADAPTOR													
<table border="0"> <tr> <td>0 PLC</td> <td>±-</td> </tr> <tr> <td>1 PLC</td> <td>±-</td> </tr> <tr> <td>2 PLC</td> <td>±.01 [.25 mm]</td> </tr> <tr> <td>3 PLC</td> <td>±.005 [.13 mm]</td> </tr> <tr> <td>4 PLC</td> <td>±-</td> </tr> <tr> <td>ANGLES</td> <td>±-</td> </tr> </table>		0 PLC	±-	1 PLC	±-	2 PLC	±.01 [.25 mm]	3 PLC	±.005 [.13 mm]	4 PLC	±-	ANGLES	±-	PRODUCT SPEC	-	
0 PLC	±-															
1 PLC	±-															
2 PLC	±.01 [.25 mm]															
3 PLC	±.005 [.13 mm]															
4 PLC	±-															
ANGLES	±-															
MATERIAL		APPLICATION SPEC	-													
FINISH		WEIGHT	-													
-		CUSTOMER DRAWING	SCALE NTS	SHEET 1 OF 1												
-			RESTRICTED TO	REV B												