

TOP VIEW

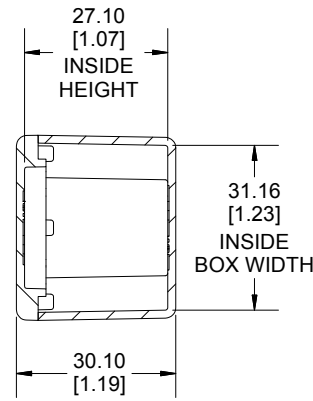

**SECTION A-A
END VIEW**

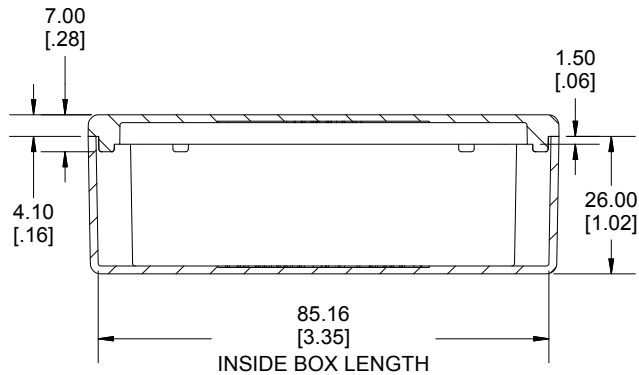
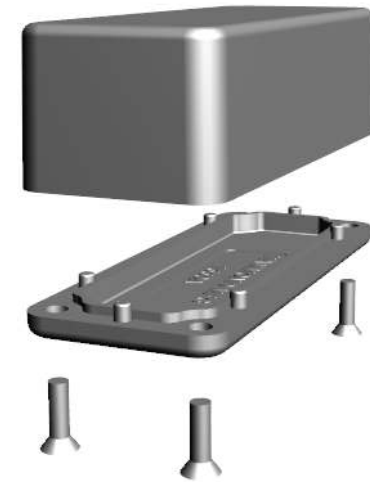

**SECTION B-B
SIDE VIEW**

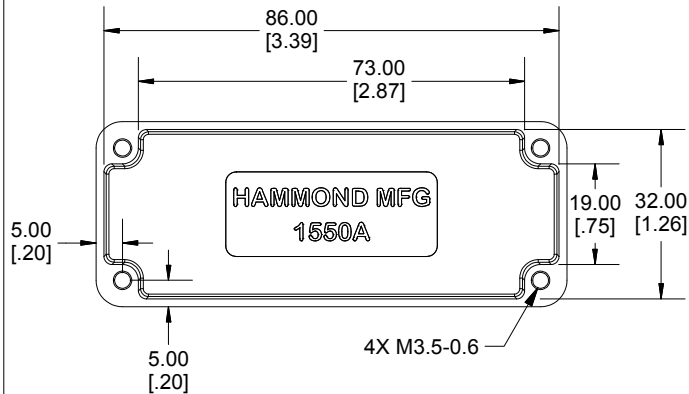
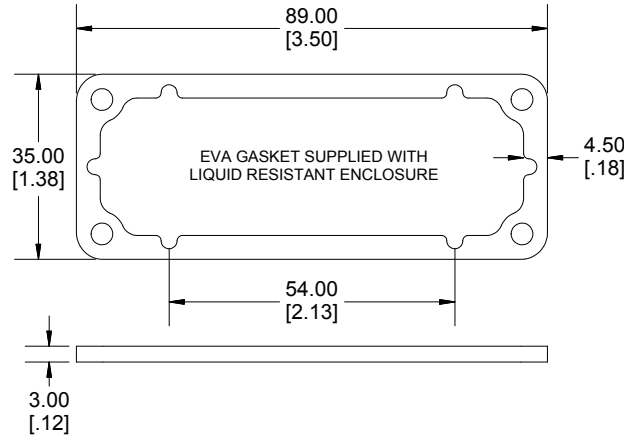

INSIDE BOX

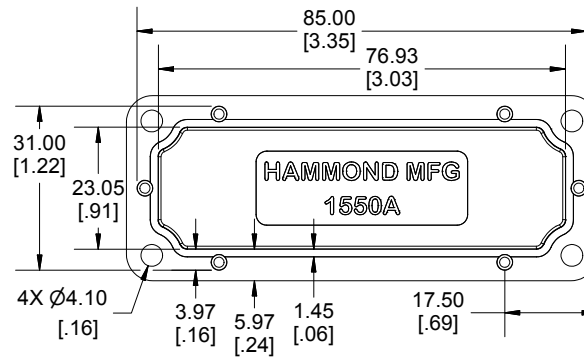

INSIDE LID

Enclosures can be Factory Modified (Milling, Drilling, Printing etc.)
Contact Factory mjm@hammondmfg.com for quotes
Solid models of this enclosure available in STEP or IGES.

NOTE

Purchased assembly includes box, lid and 4 cover screws.
Box and lid are made from Diecast Aluminum Alloy.
EVA Gasket supplied with liquid resistant enclosure.

PART NUMBERS

1550A Enclosure	
Natural Finish Enclosure	1550A
Black Textured Enclosure	1550ABK
1550A Liquid Resistant Enclosure (EVA Gasket)	
Natural Finish Enclosure	1550WA
Black Textured Enclosure	1550WABK

ACCESSORIES

Recommended Torque: 75 ozf.in / 55 cN.m

Standard Cover Screws

Plated Cover Screws (Pkg 100) [M3.5-0.6 x 12mm]	1550MS100
Black Cover Screws (Pkg 100) [M3.5-0.6 x 12mm]	1550MS100BK

Liquid Resistant Cover Screws and Gaskets

Stainless Steel Cover Screws (Pkg 100) [M3.5 x 12mm, With O-Ring]	1550WMS100
Black Stainless Steel Cover Screws (Pkg 100) [M3.5 x 12mm, With O-Ring]	1550WMS100BK
EVA Pre-formed Gasket Black	1550AEGASKET
Silicone Pre-formed Gasket Black	1550ASGASKET

Dimensions:
mm
[inches]

**HAMMOND
MANUFACTURING®**
1550A
www.hammondmfg.com