

DESCRIPTION: HIGH DENSITY VERTICAL HIGH PROFILE MACHINED

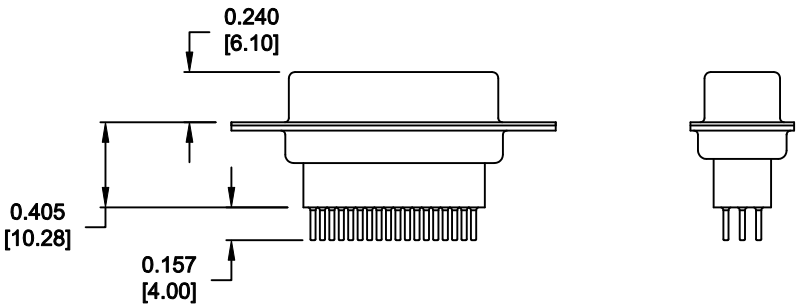
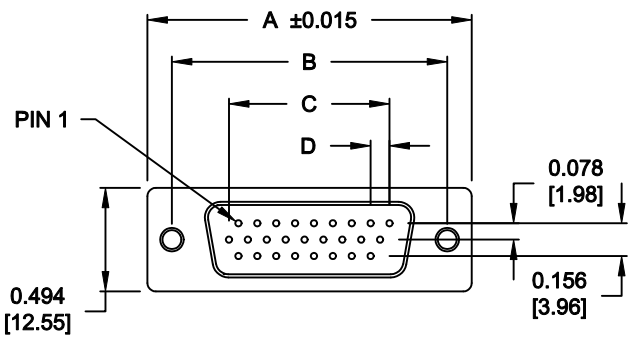

No. OF PINS	DIMENSIONS (IN.)			
	A	B	C	D
15	1.214 [30.84]	0.984 [24.99]	0.405 [10.29]	0.090 [2.29]
26	1.545 [39.24]	1.312 [33.32]	0.765 [19.43]	0.090 [2.29]
44	2.087 [53.00]	1.852 [47.04]	1.305 [33.15]	0.090 [2.29]
62	2.728 [69.30]	2.500 [63.50]	1.948 [49.47]	0.095 [2.41]
78	2.638 [67.00]	2.406 [61.10]	1.805 [45.85]	0.095 [2.41]

4 ROWS

MATERIAL:

INSULATOR: PBT, UL94V-0, 230°C PROCESS TEMP.,
 CHEMICAL RESISTANCE, COLOR - BLACK
 SHELL: STEEL, NICKEL PLATED
 CONTACT: PHOSPHOR BRONZE, GOLD PLATED

ELECTRICAL:

CURRENT RATING: 2 AMPS
 DIELECTRIC WITHSTANDING VOLTAGE: 1,000VAC rms
 INSULATION RESISTANCE: 5,000 MegOhms Min.
 CONTACT RESISTANCE: 10 MilliOhms Max.
 WORKING TEMPERATURE: -55°C TO +125°C

196-YYY-213LYY1

SERIES _____
 POSITIONS _____
 015 _____
 026 _____
 044 _____
 062 _____
 078 _____
 GENDER _____
 2 = FEMALE
 TERMINATION _____
 1 = PC MOUNT
 SHELL PLATING _____
 3 = NICKEL PLATED
 RoHS COMPLIANT (LOW TEMP. PROCESS) _____
 HARDWARE OPTIONS _____
 00 = 0.120" MOUNTING HOLE
 03 = 4-40 HEX STANDOFFS
 55 = 4-40 INSERTS
 PLATING _____
 1 = GOLD FLASH (ENTIRE CONTACT)
 2 = 30u" GOLD PLATING

DO NOT SCALE FROM DRAWING

	THESE DRAWINGS AND SPECIFICATIONS ARE THE PROPERTY OF NorComp AND SHALL NOT BE REPRODUCED, COPIED OR USED AS THE BASIS FOR THE MANUFACTURE OF SALE OF APPARATUS WITHOUT WRITTEN PERMISSION.		DRAWN: PAM JENKINS	DATE: 09-15-05
			CHECKED:	DATE:
<h1>NorComp</h1>		SCALE: 1:1	SHEET 1 OF 3	REV 7
		DWG NO. 196-YYY-213LYY1		

RoHS COMPLIANT

DESCRIPTION: HIGH DENSITY DIP SOLDER FEMALE FOOTPRINT

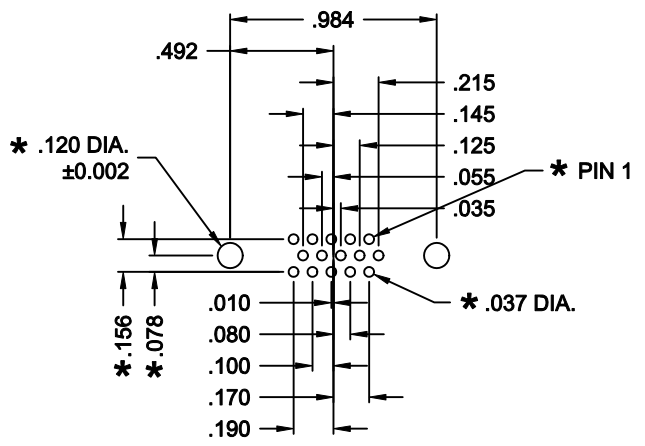

15 POSITION

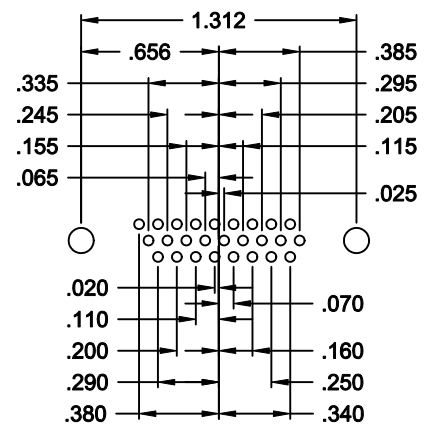

26 POSITION

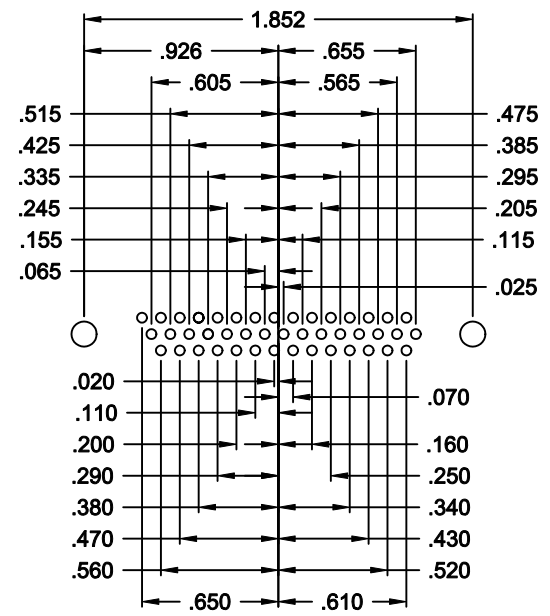

44 POSITION

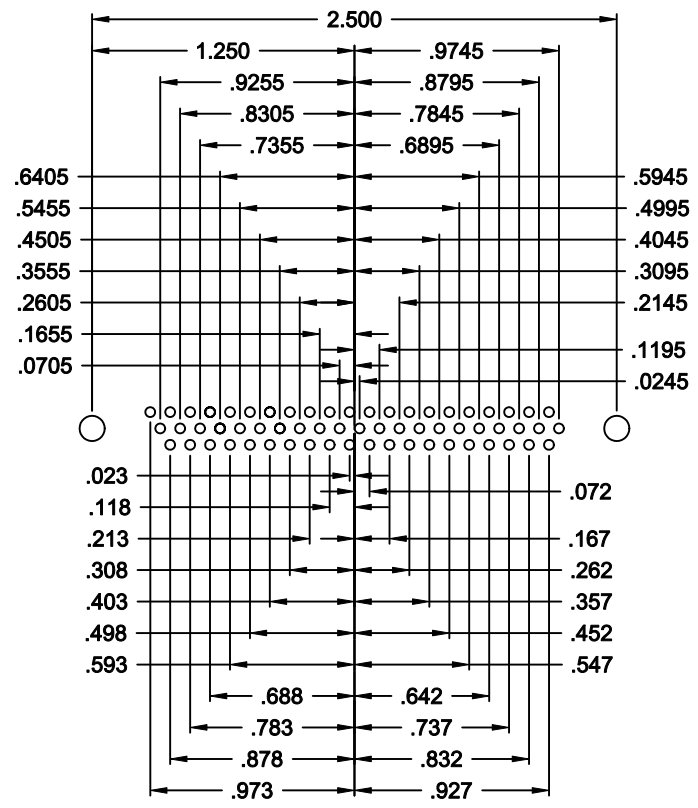

62 POSITION

ROHS COMPLIANT

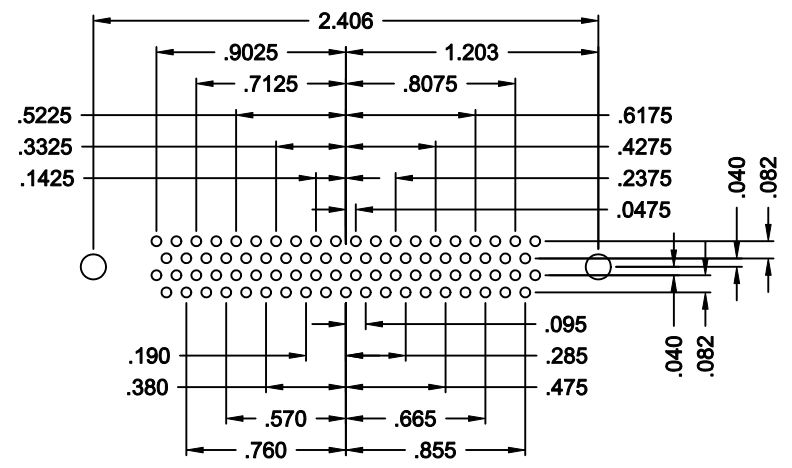

78 POSITION

**180 SERIES
HIGH DENSITY
VERTICAL**

**HOLE PATTERN SHOWN
ARE FOR FEMALE**

*** TYP. ON ALL SIZES**

DO NOT SCALE FROM DRAWING

	THESE DRAWINGS AND SPECIFICATIONS ARE THE PROPERTY OF NorComp AND SHALL NOT BE REPRODUCED, COPIED OR USED AS THE BASIS FOR THE MANUFACTURE OF SALE OF APPARATUS WITHOUT WRITTEN PERMISSION.		DRAWN: PAM JENKINS	DATE: 10-29-01
			CHECKED:	DATE:
NorComp		SCALE: 2 : 1	SHEET 2	OF 3
		DWG NO. 196-YYY-213LYY1		

55X 0.158" (BOARD SIDE)

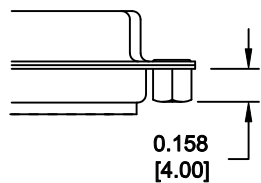

03X 0.158" (BOARD SIDE) - 0.230" MATING SIDE

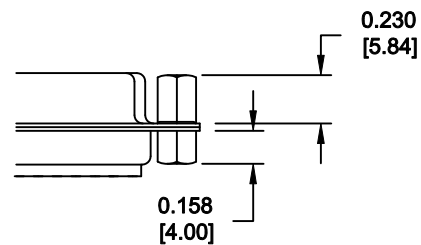

DO NOT SCALE FROM DRAWING



THESE DRAWINGS AND SPECIFICATIONS ARE THE PROPERTY OF NorComp AND SHALL NOT BE REPRODUCED, COPIED OR USED AS THE BASIS FOR THE MANUFACTURE OF SALE OF APPARATUS WITHOUT WRITTEN PERMISSION.

DRAWN: M. SIGMON		DATE: 11-19-10	
CHECKED:		DATE:	
SCALE:	SHEET 3 OF 3	REV 7	
DWG NO. 196-YYY-213LYY1			

NorComp

RoHS COMPLIANT