

SPECIFICATION

Part No. : **CAB.917**

Product Name : Taoglas Cable Assembly
N type Male Straight to
N type Female Straight
with 1M CFD-200 cable

Photo :



1.0 Cable Insertion Loss

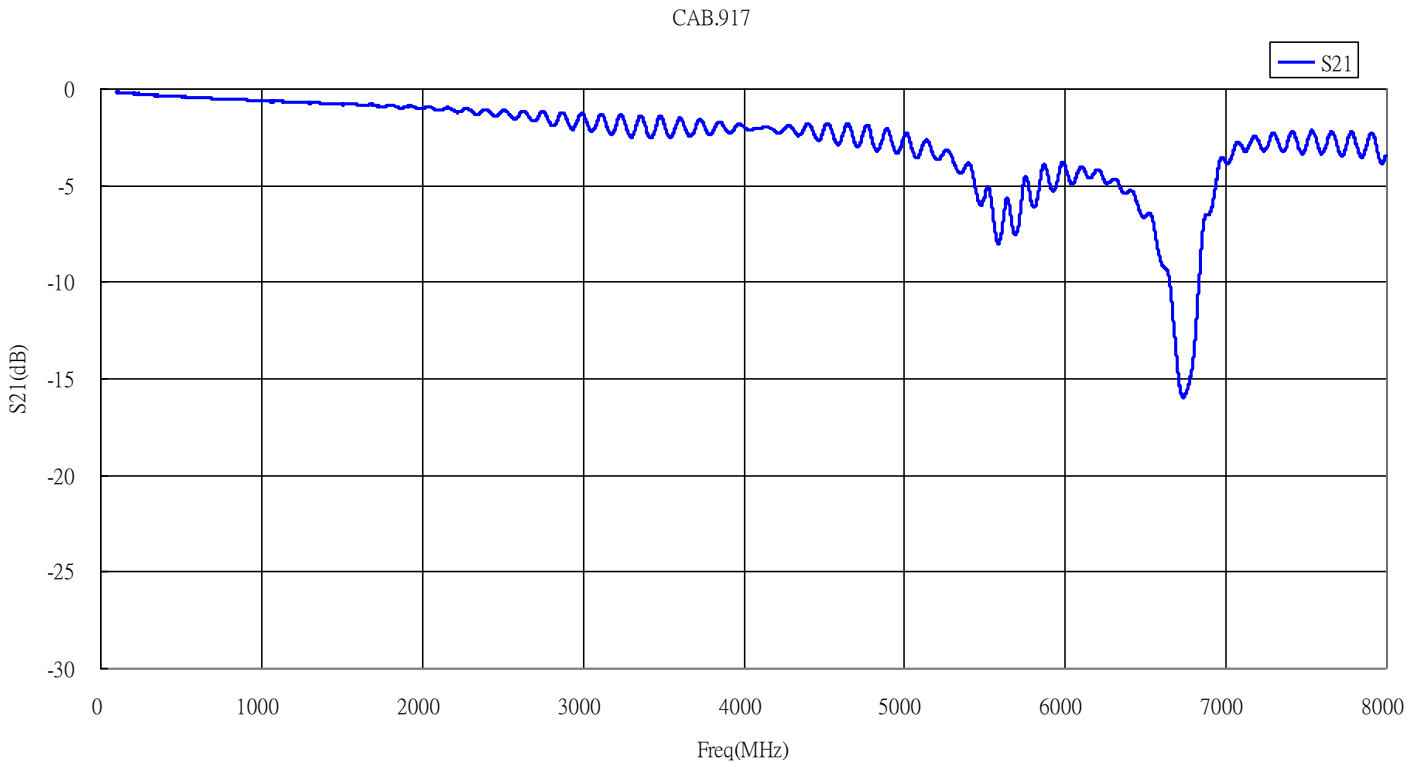

2.0 CFD-200 Cable Specification

2.1 Drawing – Cross Section

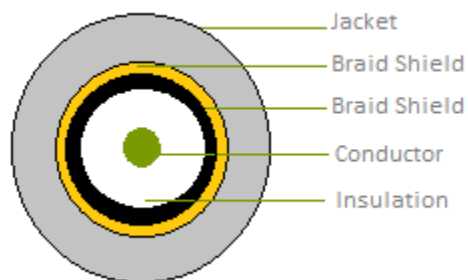

2.2 Structure and Dimensions

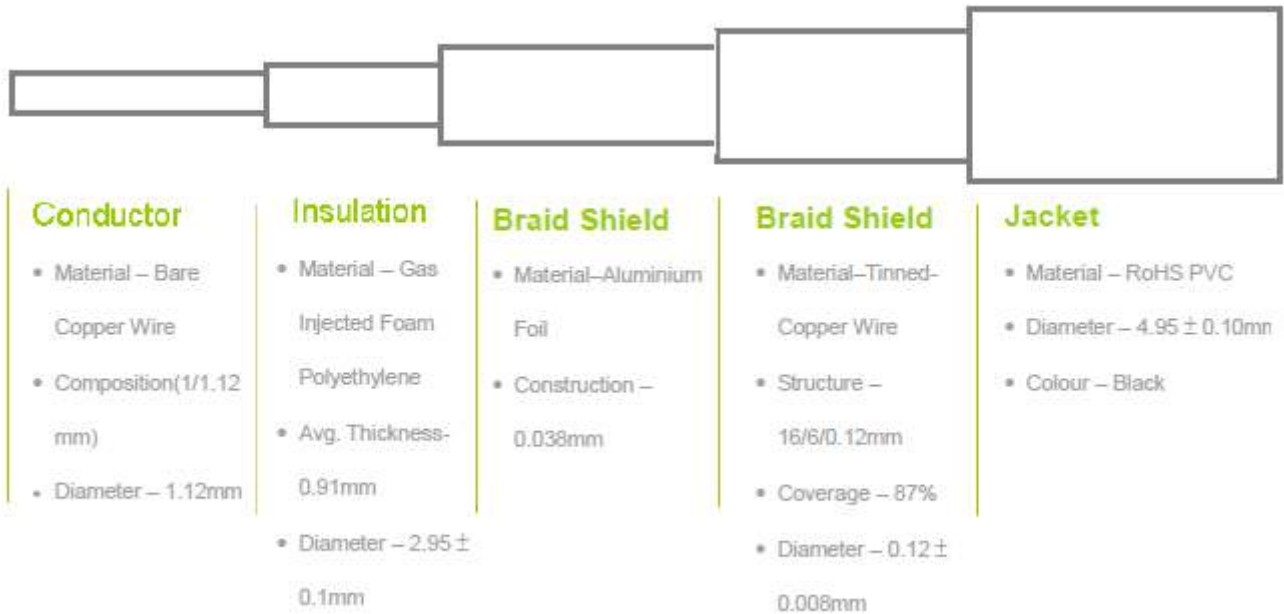

2.3 Electrical & Physical Specification

Insulation Resistance:	1000 MΩ-Km (Min)					
Capacitance	80.4 ± 3 pF/m					
Nom. Impedance	50 ± 3 Ω					
Attenuation (dB/100M)	150MHZ	450MHZ	900MHZ	1500MHZ	1800MHZ	2500MHZ
	12.1	21.6	31.2	41.1	45.3	54.4

3.0 Technical Drawing

3.1 CAB.917

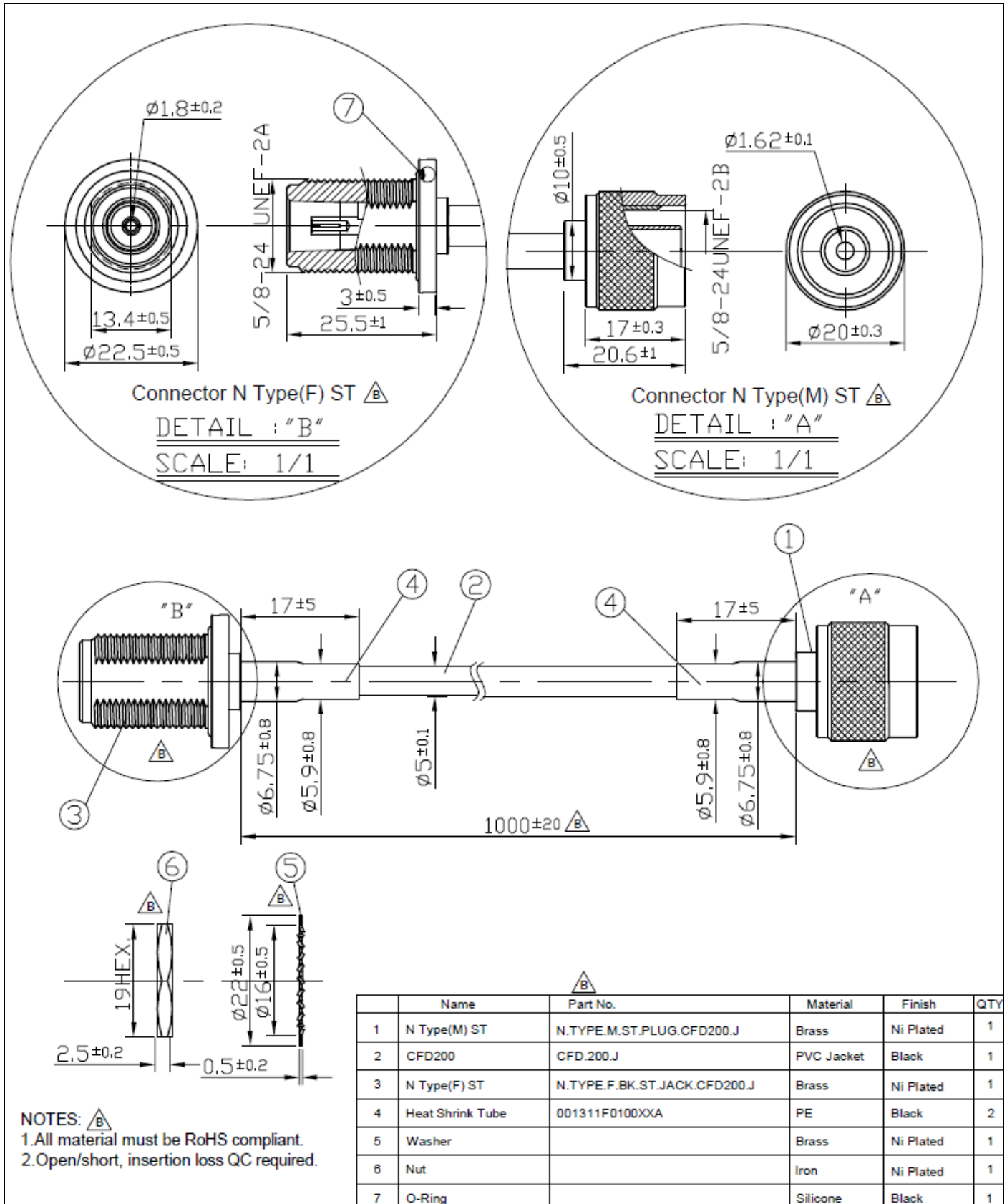

3.2 Connectors

3.2.1 N Type Male

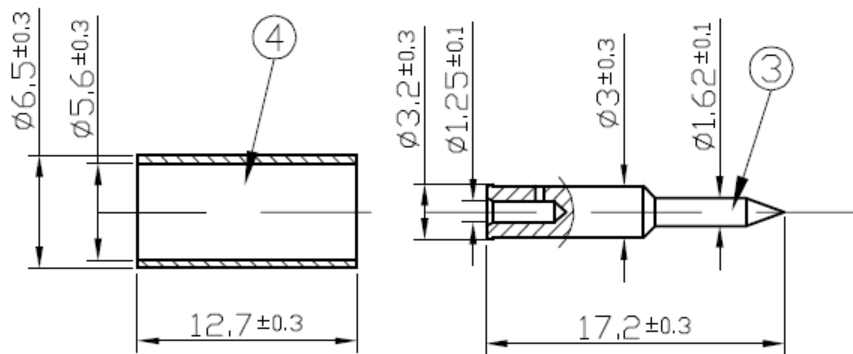
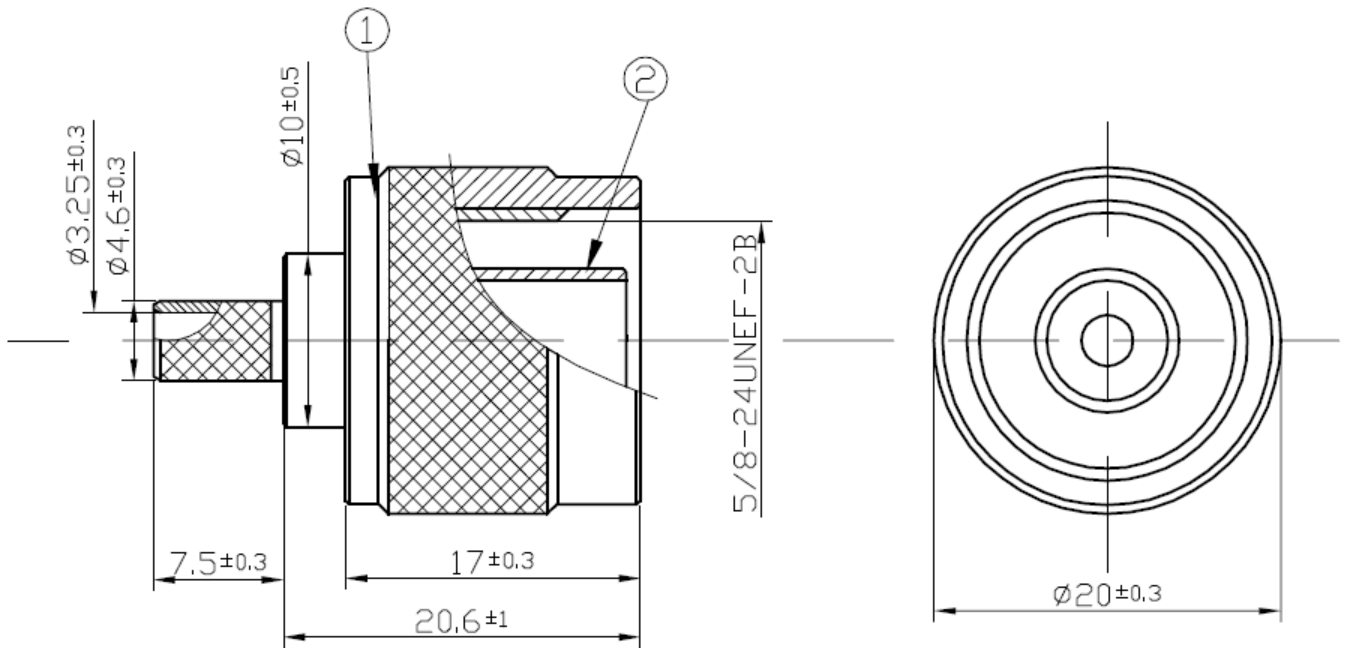

	Name	Material	Finish	QTY
1	Body	Brass	Ni Plated	1
2	Insulator	PTFE	White	1
3	PIN	Copper	Gold	1
4	Ferrule	Copper	Ni Plated	1

3.2.2 N Type Female

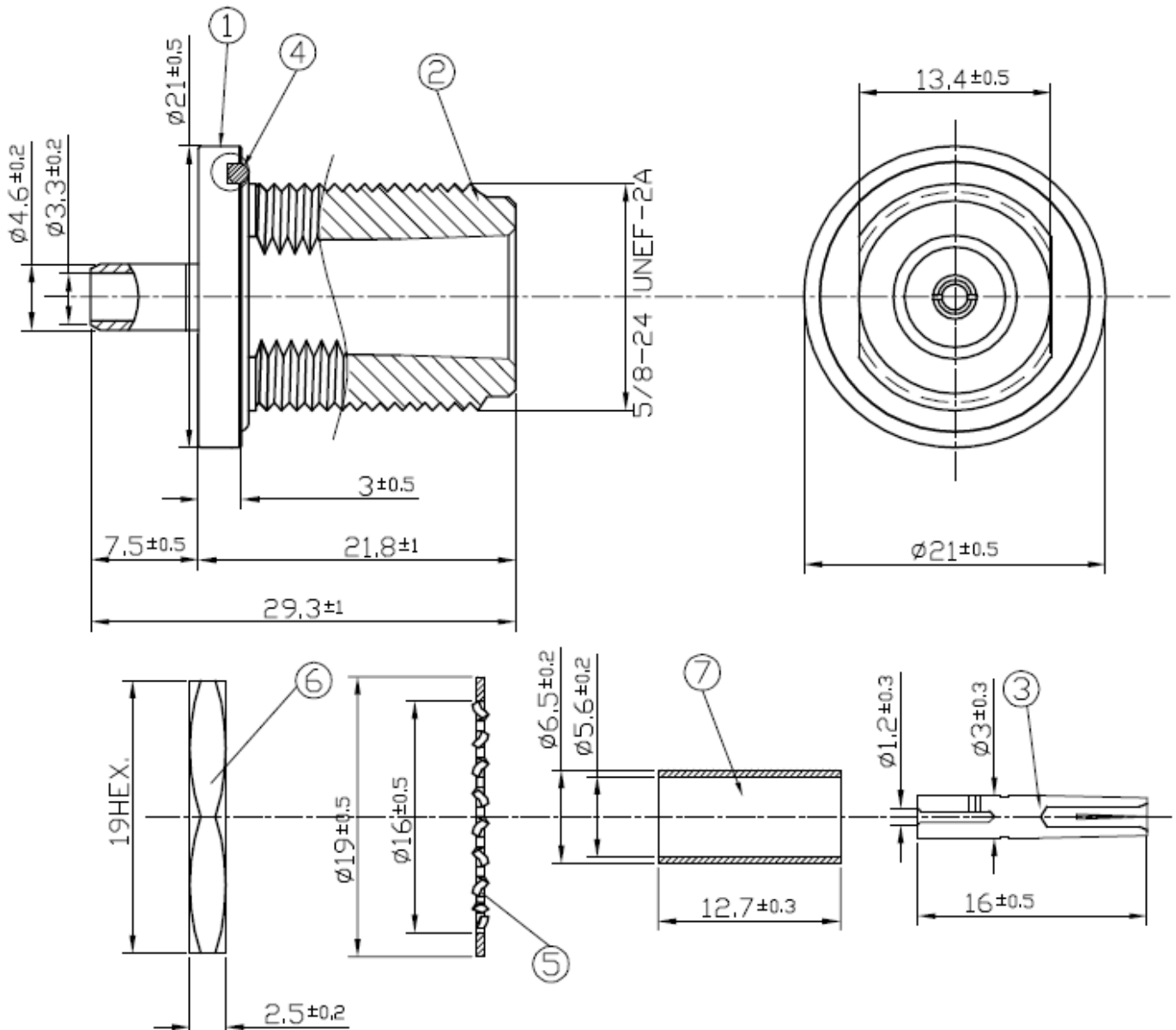

	Name	Material	Finish	QTY
1	Body	Brass	Ni Plated	1
2	Insulator	Teflon	White	1
3	Female Contact	Brass	Gold	1
4	O-Ring	Silicone	Black	1
5	Washer	Stainless	Ni Plated	1
6	Nut	Iron	Ni Plated	1
7	Ferrule	Brass	Ni Plated	1