

**QT-Brightek PLCC Series**  
**PLCC4 RGB LED with Lens**  
**Part No.: QBLP677BD-RGB5**  
**RGB5: White Face, Clear Lens**

Product: QBLP677BD-RGB5	Date: November 23, 2020	Page 1 of 10
	Version# 1.1	

---

**Table of Contents:**

Introduction .....	3
Electrical / Optical Characteristic ( $T_A=25\text{ }^\circ\text{C}$ ).....	4
Absolute Maximum Rating .....	4
Solder Profile & Footprint.....	7
Packing .....	8
Ordering Information .....	9
Revision History .....	10
Disclaimer .....	10

## Introduction

### Feature:

- Clear lens
- White face
- Package in tape and reel
- Ultra bright PLCC4 RGB LED
- Common Cathode
- InGaN technology for IB/IG
- AlInGaP technology for R
- Viewing angle: 30 deg typ.

### Description:

This PLCC4 RGB LEDs have a built in lens that provides narrow viewing angle. It is suitable for signage application.

### Application:

- Status indication
- Signage
- Signaling

### Certification & Compliance:

- TS16949
- ISO9001
- RoHS Compliant



### Dimension:

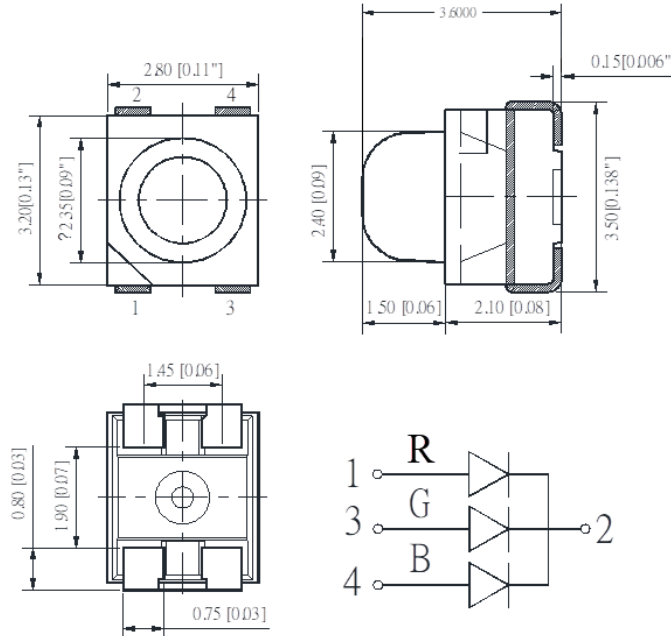

Units: mm / tolerance = +/-0.2mm

### Electrical / Optical Characteristic (T<sub>A</sub>=25 °C)

Product	Color	I <sub>F</sub> (mA)	V <sub>F</sub> (V)			λ <sub>D</sub> (nm)			I <sub>V</sub> (mcd)	
			Min.	Typ.	Max.	Min.	Typ.	Max.	Min.	Typ.
QBLP677BD- RGB5	Red	20	1.7	2.0	2.5	615	620	630	125	200
	True Green	20	2.8	3.2	3.7	520	525	530	200	340
	Blue	20	2.8	3.1	3.7	460	465	470	80	120

### Absolute Maximum Rating

Material	P <sub>d</sub> (mW)	I <sub>F</sub> (mA)	I <sub>FP</sub> (mA)*	V <sub>R</sub> (V)	T <sub>OP</sub> (°C)	T <sub>ST</sub> (°C)	T <sub>SO L</sub> (°C)**
AllnGaP (R)	75	30	125	5	-40 to +80	-40 to +85	240
InGaN (IB/IG)	111	30	125	5	-40 to +80	-40 to +85	240

\*Duty 1/8 @ 1kHz

\*\*IR Reflow for no more than 10 sec @ 260 °C

### Luminous Intensity I<sub>V</sub> for Red @ I<sub>F</sub>=20mA

Bin	Min.	Max.	Unit
K	125	160	mcd
L	160	200	
M	200	250	
N	250	320	
O	320	400	

### Luminous Intensity I<sub>V</sub> for True Green @ I<sub>F</sub>=20mA

Bin	Min.	Max.	Unit
M	200	250	mcd
N	250	320	
O	320	400	
P	400	500	
Q	500	630	

### Luminous Intensity I<sub>V</sub> for Blue @ I<sub>F</sub>=20mA

Bin	Min.	Max.	Unit
I	80	100	mcd
J	100	125	
K	125	160	
L	160	200	
M	200	250	

**Dominant Wavelength  $\lambda_D$  for Red @  $I_F=20\text{mA}$** 

Bin	Min.	Max.	Unit
s	615	620	nm
t	620	625	
u	625	630	

**Dominant Wavelength  $\lambda_D$  for True Green @  $I_F=20\text{mA}$** 

Bin	Min.	Max.	Unit
U	520	522.5	nm
V	522.5	525	
W	525	527.5	
X	527.5	530	

**Dominant Wavelength  $\lambda_D$  for Blue @  $I_F=20\text{mA}$** 

Bin	Min.	Max.	Unit
E	460	462.5	nm
F	462.5	465	
G	465	467.5	
H	467.5	470	

## Characteristic Curves

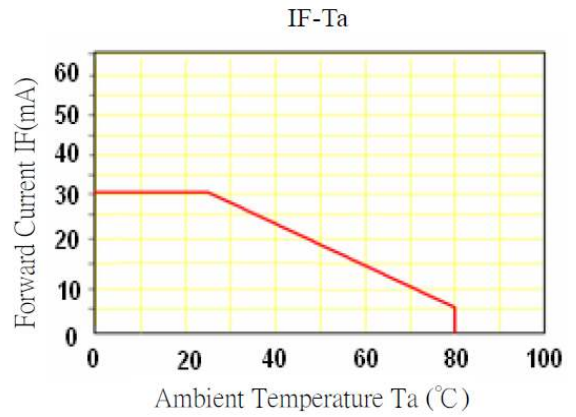
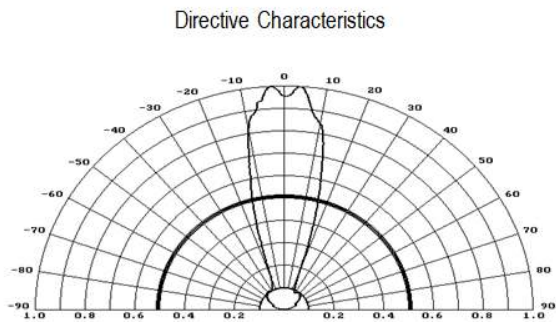
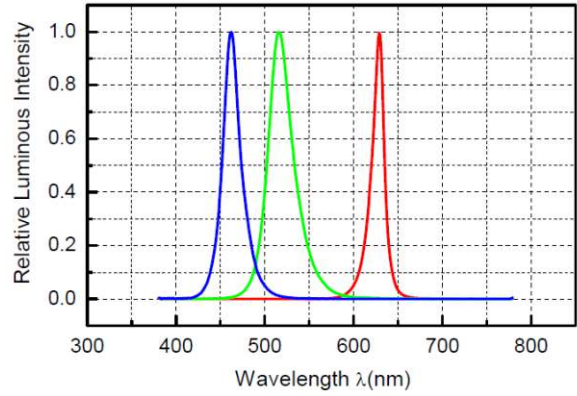
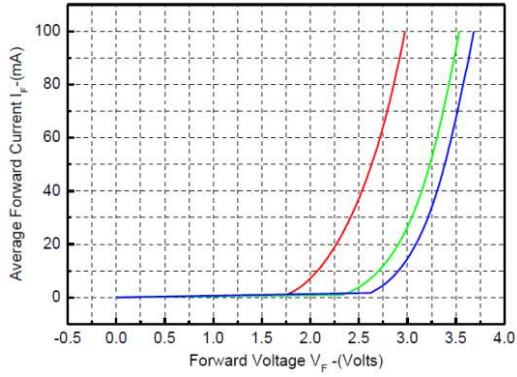

## Solder Profile & Footprint

-The recommended reflow soldering profile is as follows (temperatures indicated are as measured on the surface of the LED resin):

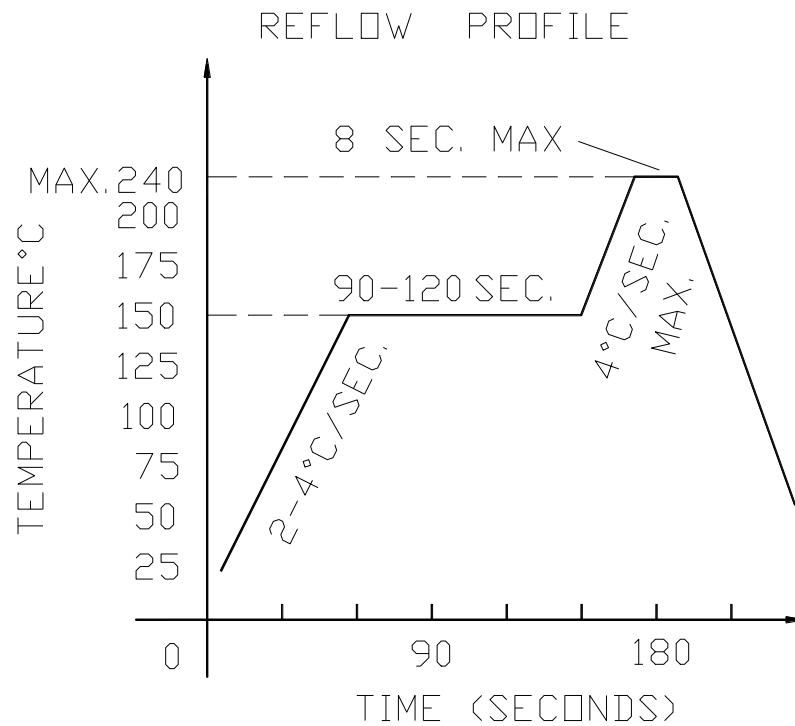

### Recommended Pad Layout

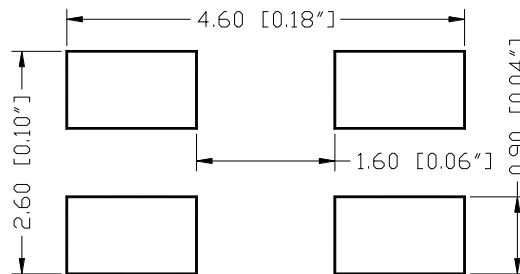

Units: mm

Tolerance:  $\pm 0.2\text{mm}$

## Packing

Reel Dimension:

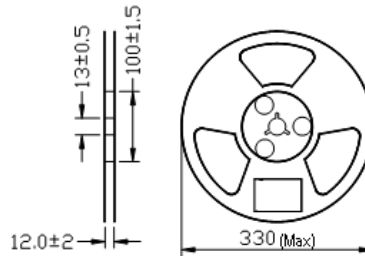

Unit: mm

Tape Dimension:

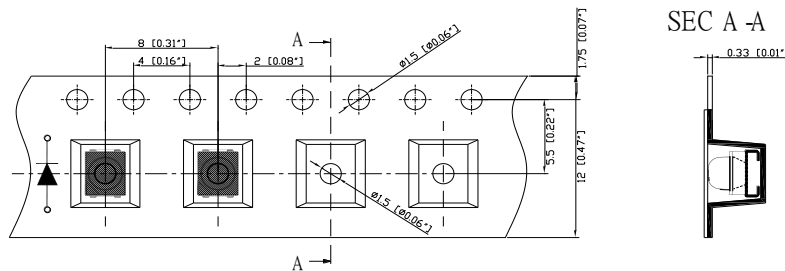

Unit: mm

Arrangement of Tape:

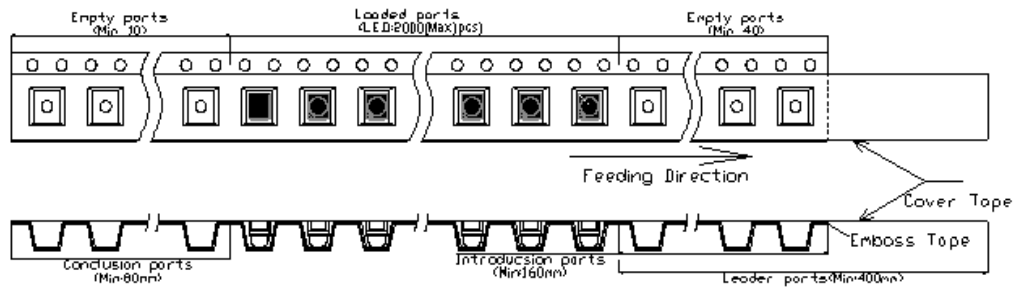

Packaging Specifications:

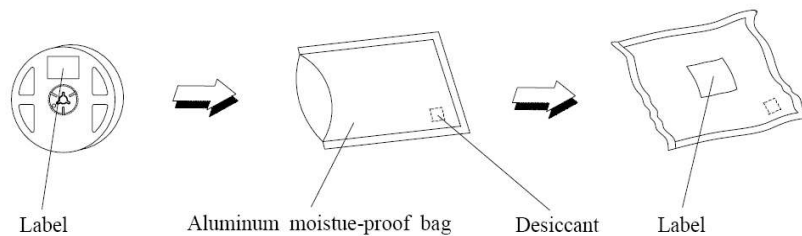





QBLP677BD-RGB5

PLCC4 RGB LED  
with lens

---

### Ordering Information

Part #	Orderable Part #	Spec Range	Quantity per reel
QBLP677BD-RGB5	QBLP677BD-RGB5	Based on page 4 and 5	2,000 units



---

## Revision History

Description:	Revision #	Revision Date
New Release of QBLP677BD-RGB5	V1.0	06/20/2018

## Disclaimer

QT-BRIGHTTEK reserves the right to make changes without further notice to any products herein to improve reliability, function or design. QT-BRIGHTTEK does not assume any liability arising out of the application or use of any product or circuit described herein; neither does it convey any license under its patent rights, nor the rights of others.

## Life Support Policy

QT-BRIGHTTEK's products are not authorized for use as critical components in life support devices or systems without the express written approval of QT-BRIGHTTEK. As used herein:

1. Life support devices or systems are devices or systems which, (a) are intended for surgical implant into the body, or (b) support or sustain life, and (c) whose failure to perform when properly used in accordance with instructions for use provided in the labeling, can be reasonably expected to result in a significant injury of the user.
2. A critical component in any component of a life support device or system whose failure to perform can be reasonably expected to cause the failure of the life support device or system, or to affect its safety or effectiveness.